

B115_B B110_B B110_{BTC} B100_B B100_{BTC} B90_B



B115B - B110B/BTC B90B - B100B/BTC

BUCKET CAPACITY

UP TO 1,2 M³ BUCKET

1,0 M³ BUCKET

ENGINE POWER

110 HP

100 HP



BUILT AROUND YOU

B115B/B110B/B100B/B90B

ENVIRONMENTAL EFFICIENCY

10% reduction in fuel
consumption and emissions

BEST IN CLASS PRODUCTIVITY

10% more power than
competitive machines





HIGH OPERATING COMFORT

Class-leading operator environment

LOW COST OF OWNERSHIP

Fuel efficient
Easy to maintain

B115B/B110B/B100B/B90B

ENVIRONMENTAL CONCERN

LESS FUEL CONSUMPTION RESULTS IN LOWER ENGINE EMISSIONS

- 10% Fuel



The 4.5 litre turbocharged engines for the new machines are provided by FPT Industrial, a world-wide leader in the design, production and sale of powertrains for industrial applications, supplying among others Fiat Industrial brands such as New Holland Construction and Iveco.

The Variable Displacement Pump hydraulic system is standard on B100B and above, contributing to a 10% fuel saving and a rapid return on investment.

LOW NOISE LEVELS FOR URBAN JOBSITES

- Reduced emission Tier III engine
- Low external noise levels
- New Holland CB90S is a silenced hydraulic breaker especially designed for TLB use
- Rubber pads under the stabilizers reduce ground damage in sensitive operating conditions

BEST IN CLASS PRODUCTIVITY

COMBINING THE PERFORMANCE OF A WHEEL LOADER AND AN EXCAVATOR



DIG, LOAD AND GRADE LIKE A CRAWLER EXCAVATOR!

Thanks to the curved arm design, load sensing hydraulics and extensive backhoe reach



BI15B/BI10B/BI00B/B90B

BEST IN CLASS PRODUCTIVITY

THE ABILITY TO DIG AND LOAD LIKE A POWERFUL WHEEL LOADER



Lifts 3,2 ton at 3,5 m dumping height!

JUST LIKE A WHEEL LOADER!

- Maximize bucket filling with Powershift transmission and standard kick down function
- Easy leveling thanks to loader float function controlled from the joystick
- Shorter cycle times thanks to Automatic Return-to-dig button
- No loader arm bounce and increased bucket retention with optional Glide Ride
- Excellent traction in the worst conditions thanks to a 100% lockable differential, or a limited slip differential on the BI15B



MORE POWER



SMOOTH CONTROL UNDER LOAD WITH POWERSHIFT



Available on B110B and B115B, the Powershift transmission provides maximum operator comfort . In “full automatic mode” the transmission will auto-shift either up or down the gears, depending on speed and load, improving cycle times and simplifying road travel

For less sophistication, you can opt for our robust PowerShuttle transmission that is available on all models. It is the standard transmission on B90B and B100B

MINIMIZED DOWNTIME



Hydraulic side shift (option): Fast and accurate positioning of the boom without damaging the ground



Excellent lighting for night working



4 front working lights and 4 rear working lights (except B90B: 2 front + 2 rear)

B115B/B110B/B100B/B90B

**OPERATOR COMFORT MATTERS,
WELCOME ON BOARD!
ROOMY CAB WITH EASY ACCESS**



SIMULTANEOUS CONTROL

All loader and bucket controls are located on the joystick

DELUXE OPERATOR'S SEAT

- Adjustable comfortable armrest
- Pneumatically height adjustable suspension seat

EASY CLEANING

- Removable floor covering and flat cab floor make cleaning easier

STORAGE ROOM

- Cup holder
- Wider glove box

EXCELLENT VENTILATION

- Partial or full opening of both front and rear side windows
- Cab fan (option)
- Standard heater or air conditioning (option)

ALL CONTROLS UNDER YOUR HAND



FULLY ADJUSTABLE WORKING POSITION



QUIET WORKING ENVIRONMENT:

Cab interior 77 dB / exterior 103 dB

B | I | 5B / B | I | 0B / B | I | 00B / B90B

LOW COST OF OWNERSHIP



10% Fuel saving

A SIGNIFICANT COST SAVING

If your New Holland machine is used for 800h/year, we estimate that our new hydraulic system, including the Variable Displacement Pump, will result in average savings of up to 1000 €/year



Vandal proof

PROTECT YOUR INVESTMENT ON SITE

- Secure hydraulic oil cap-breather
- Battery box is locked with a key
- Engine hood is lockable with a key
- An anti-theft device is available as option



Smart design

DRIVING LIGHT PROTECTION

Rear driving lights have 2 positions:

- transport position: on the stabs
- working position: on the cab, (see picture →) so that they are completely protected

WINDOW OPENING

Ventilation is optimized in the cab thanks to the partial or total opening of the side windows and the fully retractable rear screen





Maintenance friendly

BEST IN CLASS ACCESSIBILITY

Tilting engine hood provides excellent ground level access to the engine and service points.



CENTRAL SERVICE POINT LOCATION

Daily check and fill points are accessible from ground level for time saving.

On the machine's left side, just above the fuel tank, you can easily reach:

- the hydraulic pressure check points,
- steering circuit,
- pilot control,

All grouped together for time and cost reduction whilst improving efficiency, durability and performance



EASY DIAGNOSIS

Rapid engine diagnosis is possible with the New Holland Electronic Service Tool

NO SEPARATE BRAKE FLUID

Hydraulic oil is used as the brake fluid, so no need to use separate tank and no risk of using the wrong fluid



PROTECTED BATTERY EASY TO REACH

The Battery is easily reached in the tool box located on the right side, underneath the cab. By removing one panel it is simple to access both the battery and the master switch.



BI15B/BI10B/BI00B/B90B



BI15B



BI10B/BI10BTC

MAIN FEATURES

SPECIFICATIONS

HYDRAULICS

Type of pump and flow

Maximum pressure level

BATTERY

OPERATING WEIGHT

- with standard backhoe and 6-in-1 bucket
- with Extendible Backhoe and 6-in-1 bucket

TURNING RADIUS (front tyres 12.5/80-18, wheel not braked, 4WD engaged)

- at ext. edge of front tires
- at bucket corner

AXLES, TYRES & BRAKE

Brakes:

Tires can be multipurpose, hard soil specific or soft soil specific
Tires

Front axle with +/- 11° oscillation

CAPACITIES

Fuel tank

Cooling system

EMISSIONS

CO₂ emissions (g/kWh)

NO_x emissions

HC emissions

CO emissions

PM emissions

NO_x + NMHC emissions

NOISE

Internal (dB(A))

External (dB(A))

VIBRATION LEVELS

Upper limbs 2,5 m/s²

Abdomen 0,5 m/s²

BI15B

4 equal-sized wheel steer
1.2 m³ bucket
112 hp
Powershift Transmission (standard)
Pilot / Mechanical Control
4.5 litre FPT Industrial engine turbocharged,
common rail injection
110 hp @ 2200 rpm / 520 Nm @ 1400 rpm

Variable Displ. 6 to 165 l/min @ 2200 rpm
Twin Gear Pump 151/min @ 2200 rpm
205 bars

12V 95Ah, 900 A (SAE) - 120 A

8870

9100

4300 mm

5600 mm

Power Brake with 2472 cm² friction area

24" front with 24"
or 28" front with 28"
Limited Slip Differential

135 l

24 l

744

3,6

0,1

0,9

0,13

3,7

77

103

2,5

0,5



BI00B/BI00BTC



B90B

BI10B	BI00BTC	B90B
20" or 18" tires 2-wheel steer 1.2 m ³ bucket or 1.0 m ³ bucket 112 hp Powershift /Powershuttle Transmission Pilot / Mechanical Control 4.5 litre FPT Industrial engine turbocharged, common rail injection 110 hp @ 2200 rpm / 520 Nm @ 1400 rpm	18" tires 2-wheel steer 1.0 m ³ bucket 100 hp Powershuttle Transmission (standard) Pilot / Mechanical Control 4.5 litre FPT Industrial engine turbocharged, common rail injection 97 hp @ 2200 rpm / 450 Nm @ 1400 rpm	18" tires 2-wheel steer 1.0 m ³ bucket 100 hp Powershuttle Transmission (standard) Mechanical Control (standard) 4.5 litre FPT Industrial engine turbocharged and aftercooled, direct mechanical injection 97 hp @ 2200 rpm / 400 Nm @ 1250 rpm
Variable Displ. 6 to 165 l/min @ 2200 rpm Twin Gear Pump 151/min @ 2200 rpm 205 bars	Variable Displacement 6 to 156 l/min @ 2200 rpm 205 bars	Twin Gear Pump 151 l/min @ 2200 rpm 205 bars
12V 95Ah, 900 A (SAE) - 120 A	12V 95Ah, 900 A (SAE) - 120 A	12V 95Ah, 900 A (SAE) - 120 A
8270 8500	8120 8350	7970 8200
4300 mm 5600 mm	4300 mm 5600 mm	4300 mm 5600 mm
Power Brake with 2472 cm ² friction area	Power Brake with 2472 cm ² friction area	Power Brake with 2472 cm ² friction area
18" front with 26" or 28" rear or 20" front with 30" rear 100% lockable	18" front with 26" or 28" rear 100% lockable	18" front with 26" or 28" rear - 100% lockable
135 l 24 l	135 l 24 l	135 l 24 l
744 3,64,4 0,10,1 0,91,8 0,13 3,7	790 4,1 0,1 1,8 0,25 4,5	773 0,26 4,2
7777 103	77 103	102
2,5 0,5	2,5 0,5	2,5 0,5

BI15B/BI10B/BI100B/B90B

SPECIFICATIONS

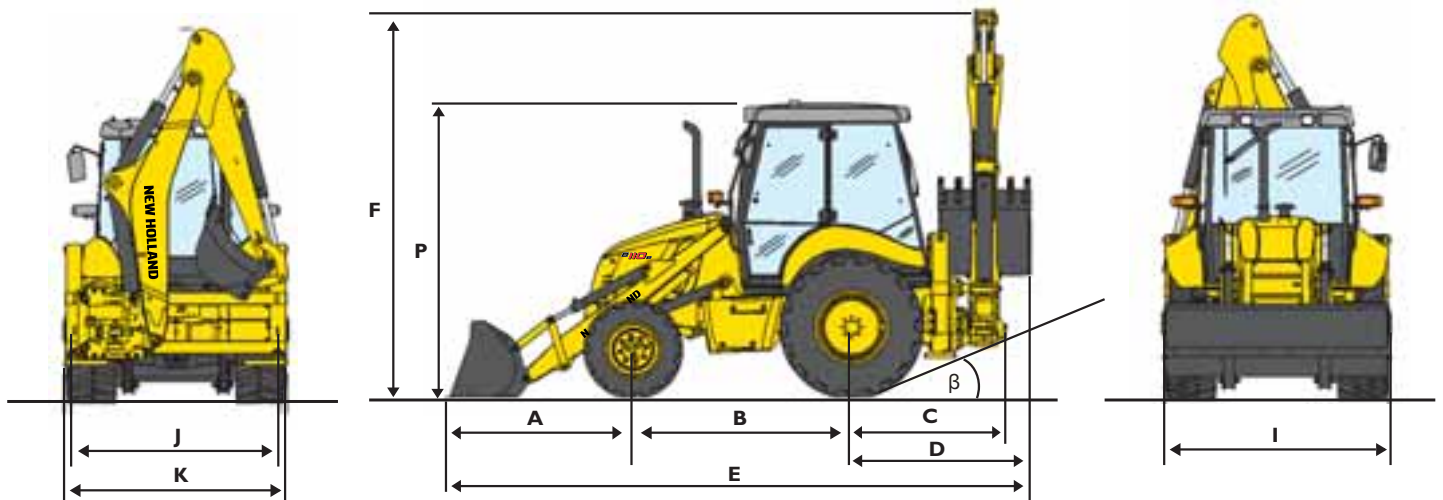

		BI15B		BI10B/BI10BTC	
OVERALL DIMENSIONS					
A	Ground distance over front axle	mm	1965		1870
B	Wheelbase	mm	2200		2175
C	Pivot distance over rear axle	mm	1325		1320
D	Max distance over rear axle (with 915 mm backhoe bucket)	mm	1780		1780
E	Overall length	mm	5945		5825
F	Height to top of boom	mm	3930		3825
β	Back ramp angle	°	22		23
P	Cab height	mm	2960		2940
I	Loader bucket width	mm	2400		2250/2400
J	Stabiliser width	mm	2250		2250
K	Overall width	mm	2325		2325
LOADER SPECIFICATIONS			TC version		STD version
	Maximum loader breakout force	daN	7400	6650	6900
	Lifting capacity to maximum height	kg	3550	3195	3550
L	Digging depth	mm	115	125	75
M	Bucket roll back angle on ground	°	45	46	40
N	Reach at full height	mm	825	813	785
O	Maximum operating height	mm	4480	4405	4330
G	Hinge pin height	mm	3490	3460	3500
H	Maximum dump height under bucket at 45°	mm	2650	2693	2780
BACKHOE SPECIFICATIONS			retracted	extended	retracted
	Bucket Breakout force	daN	6400		6400
	Dipper breakout force (Std Dipper/HED retracted)	daN	4620		4620
	Dipper breakout force (HED extended)	daN	3200		3200
R	Digging reach at max height	mm	2315	3130	2330
S	Bucket rotation	°	204	204	204
T	Digging height	mm	5815	6475	5650
U	Dumping height	mm	4090	4750	3930
V	Digging reach at ground level	mm	5850	6810	5860
Z	Digging depth	mm	4565	5600	4710

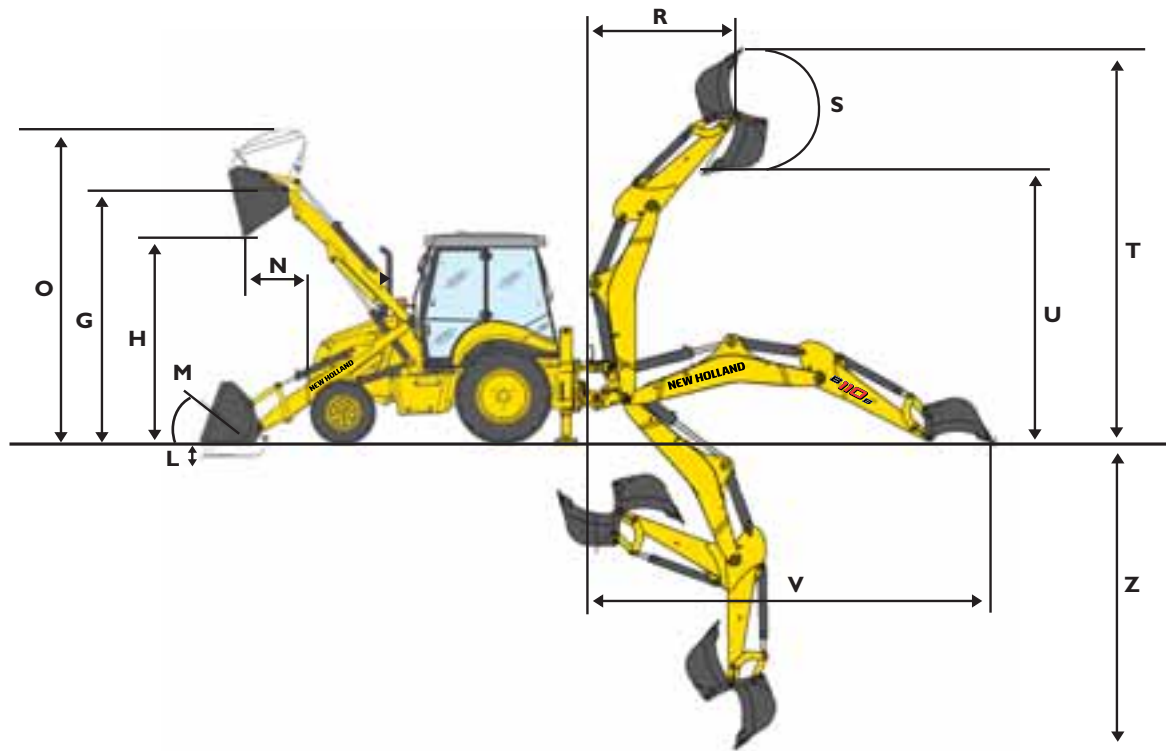

		B100B/B100BTC		B90B	
OVERALL DIMENSIONS					
A	Ground distance over front axle	mm	1870		1870
B	Wheelbase	mm	2175		2175
C	Pivot distance over rear axle	mm	1320		1320
D	Max distance over rear axle (with 915 mm backhoe bucket)	mm	1780		1780
E	Overall length	mm	5825		5825
F	Height to top of boom	mm	3875		3875
β	Back ramp angle	°	23		23°
P	Cab height	mm	2940		2940
I	Loader bucket width	mm	2250		2250
J	Stabiliser width	mm	2250		2250
K	Overall width	mm	2325		2325
LOADER SPECIFICATIONS			TC version	STD version	STD version
	Maximum loader breakout force	daN	6650	6900	6900
	Lifting capacity to maximum height	kg	3195	3550	3550
L	Digging depth	mm	125	75	75
M	Bucket roll back angle on ground	°	46	40	40
N	Reach at full height	mm	813	785	785
O	Maximum operating height	mm	4405	4330	4330
G	Hinge pin height	mm	3460	3500	3500
H	Maximum dump height under bucket at 45°	mm	2693	2780	2780
BACKHOE SPECIFICATIONS			retracted	extended	retracted extended
	Bucket Breakout force	daN	6400		6400
	Dipper breakout force (Std Dipper/HED retracted)	daN	4620		4620
	Dipper breakout force (HED extended)	daN	3200		3200
R	Digging reach at max height	mm	2330	3190	2330 3190
S	Bucket rotation	°	204	204	204 204
T	Digging height	mm	5650	6305	5650 6305
U	Dumping height	mm	3930	4585	3930 4585
V	Digging reach at ground level	mm	5870	6815	5870 6815
Z	Digging depth	mm	4710	5750	4710 5750

ATTACHMENTS OFFERING

	Width	Capacity	Weight	Hydraulics	
BUCKETS LOADER					
 6 in 1  4 in 1	2250 mm	1000 l	300 Kg	Hydraulic line, double acting	B90B - B100B B100B B110B - B115B
	2400 mm	1200 l	380 Kg		
BUCKETS BACKHOE					
	300 mm	96 l	130 Kg		
	400 mm	100 l	140 Kg		
	450 mm	150 l	158 Kg		
	600 mm	220 l	187 Kg		
	760 mm	290 l	214 Kg		
	915 mm	360 l	240 Kg		
DITCH CLEANING BUCKET					
	1200 mm				
	1300 mm				
	1400 mm				
	1500 mm				
HAMMER					
	Model	Tool dia.	Weight		
	CB65B	63 mm	310 Kg		
	CB90S	80 mm	360 Kg		
	hydraulic circuit, simple or double acting				
SNOW BLADE					
 2640 mm	Specially designed for snow removal in tough conditions. Hydraulically powered with 30° angle to the right or left. Double acting hydraulic circuit is necessary.				
AUGERS					
	A complete range of augers from 150 to 1,050 mm diameter is available for each application: installation of telegraph poles, electricity pylons, signposts, pillars, tree and shrub planting. For more details consult your dealer.				

AT YOUR OWN DEALERSHIP

The information contained in this brochure is intended to be of general nature. The NEW HOLLAND CONSTRUCTION MACHINERY S.p.A. company may at any time and from time to time, for technical or other necessary reasons, modify any of the details or specifications of the product described in this brochure. Illustrations do not necessarily show products in standard conditions. The dimensions, weights and capacities shown herein, as well as any conversion data used, are approximate only and are subject to variations within normal manufacturing techniques.

Printed on recycled paper
CoC-FSC 000010 CQ Mixed sources



Printed in Italy - MediaCross Firenze - Cod. IRI 207NCGB - Printed 09/12



BUILT AROUND YOU

WWW.NEWHOLLAND.COM