

E245C

TIER 3



E245C

ENGINE POWER	118 kW - 160 hp
MAX OPERATING WEIGHT	25418 Kg
BUCKET CAPACITY	0.52 m ³ - 1.31 m ³



BUILT AROUND YOU

AS LONG AS WE KEEP BUILDING ROADS, THERE

**10% MORE
PRODUCTIVITY**

**10% MORE
FUEL SAVINGS**



E WILL ALWAYS BE A JOURNEY TO UNDERTAKE

**EVOLUTION
IN COMFORT
AND SAFETY**

**BUILT-IN
SERVICEABILITY
AND RELIABILITY**



THE MAIN COMPONENTS OF OUR CRA

1 HEAVY-DUTY DESIGN

The C Series excavators are designed and built to deliver the ultimate reliability and durability that customers expect. The long undercarriage provides dynamic stability and performance.

2 INTELLIGENT HYDRAULICS

New Holland's Hydrotonic combines highly advanced electronic technology with a sophisticated hydraulic system, and has been designed to maximise the machines' performance according to the job at hand. The new ECO working mode optimizes fuel consumption while maintaining good performance



WLER EXCAVATOR

3 NEW EVO CAB

The ROPS/FOPS compliant EVO cab provides the ultimate comfortable and safe work environment with exceptional all-round visibility and remarkably low noise and vibration levels.



2

3

1

MORE PRODUCTIVITY



DYNAMIC STABILITY

The heavy-duty design is a perfect match with the machine's powerful performance. The version LC features a long 9 rollers and heavy-duty undercarriage that provides the best dynamic stability on the market, ensuring a safe and productive performance on all terrains.

SUPERIOR PERFORMANCE

The exceptional stability and optimal weight distribution enable the operator to make the most of the E245C's superior breakout force and lifting capacity. The Continuous Power Boost delivers extra power as and when needed, raising hydraulic pressure from 34.3 to 37.8 Mpa. Travelling on inclines and difficult terrain is easy with the excellent drawbar pull.



TOP PERFORMANCE IN ALL WORKING CONDITIONS

INTELLIGENT HYDRAULIC SYSTEM

The Hydrotronic combines advanced electronic technology that provides full just-in-time control of all machine functions with a sophisticated high-efficiency hydraulic system. It continuously optimizes hydraulic output according to the operator's demands for the job at hand.

+10%
PRODUCTIVITY



A PERFECT COMBINATION OF SPEED, EFFICIENCY AND CONTROL

SPEED AND CONTROL WITH D.O.C.

With the Dipperstick Optimized Control (D.O.C.), the excavator always works with two pumps to ensure the operator always has the flow and speed he needs. The Hydrotonic continuously adjusts the flow and speed to match the requirements, ensuring a smooth transition when switching from lighter work to heavy digging.

SPEED AND EFFICIENCY WITH CONFLUX

The Conflux is an automatic hydraulic regeneration feature that diverts unused oil to feed the cylinder that needs it. This process is faster and more energy efficient than re-pumping oil, resulting in faster “dipper in” movement and greater efficiency.

FAST CYCLE TIME

The integrated swing priority ensures a seamless transition of additional pump power to the swing function when needed.



FLEXIBILITY AND VERSATILITY

The new generation Advanced Electronic Processor (A.E.P.) provides highly responsive controls and delivers extra power when needed. The operator can easily monitor and select the main working parameters, maintenance notifications, self diagnosis and operating data storage. Attachment management is extremely versatile, as the operator can set flow and pressure with up to 20 attachment pre-settings.

SMOOTH OPERATIONS

The high-efficiency hydraulics and new joysticks result in smooth operation and outstanding control, especially during simultaneous operation, leveling and other tasks requiring high precision. The optional Hydraulic Proportional Controls (HPC) further increase productivity and reduce operator fatigue.

EFFICIENCY



THE MOST FUEL EFFICIENT CRAWLER EXCAVATOR WE HAVE EVER BUILT

New Holland excavators have a reputation for industry leading fuel efficiency; The C Series takes it to a whole new level.

ENGINE AND HYDRAULIC POWER: THE PERFECT MATCH

The high-efficiency hydraulics supply high flow at low rpm, maximizing fuel efficiency. In addition, the Hydrotronic optimizes the performance and efficiency of the machine: it maintains engine speed at the required level, preventing it from dropping. It reduces pump displacement in case of overload and continuously adjusts oil flow to avoid overloading the engine or the pumps.

HIGH-EFFICIENCY HYDRAULICS

The new improved hydraulic system minimizes friction losses and pressure drops, while the Hydrotronic advanced electronic technology ensures 100 per cent pump utilization in all applications. The result: maximum controllability, speed and power combined with minimum fuel consumption.

**-10%
FUEL**



OPTIMIZE EFFICIENCY WITH WORKING MODES

- H Heavy-duty working mode for maximum speed and productivity
- S Standard mode for performance and fuel savings
- E Eco mode which optimizes fuel consumption

TAKE CONTROL OF YOUR MACHINE'S EFFICIENCY

The new multifunctional monitor puts the operator in full control of the machines' efficiency, with the fuel economy meter and ECO icon indicating when the machine is operating most efficiently.

A COMMITTED PARTNER



DESIGNED WITH ENVIRONMENTAL CARE

New Holland has a long history of designing products with emissions levels well below regulatory levels.

LEADER IN SUSTAINABILITY

New Holland's extensive offering of low emission products, our continued focus on reducing our environmental footprint throughout our products' entire life cycle and our involvement in the community have contributed to our parent company, CNH Industrial, being recognised as Industry Leader by the Dow Jones Sustainability Index (DJSI) World and DJSI Europe. These prestigious equity indexes only admit companies that are best-in-class in managing their businesses, from an economic as well as social and environmental perspective. CNH Industrial received a score of 88/100 compared to an average of 49/100 for all companies in its sector, and was awarded first place.



EXCELLENT ALL-ROUND VISIBILITY

The EVO cab is designed to maximize visibility, with a full size right window and optional rear-view camera.

SAFE OBJECT HANDLING

C Series excavators are equipped with all the safety devices required by European Standards EN 474-5 : 1996 for object handling operations .The optional Object Handling Kit is available, for maximum operator confidence.The Heavy Lift function provides additional lifting capacity and more precision during load placement, which add up to safer operation.

EVOLUTION IN SAFETY

The reinforced structure of the cab complies with ROPS and FOPS (optional).

Together with the optional front guard it contributes to providing a safe working environment for the operator.

ROPS certified cab - ISO 12117-2

FOPS protection - ISO 10262 level 2

WELCOME ON BOARD



EVOLUTION IN COMFORT

The spacious EVO cab is designed to maximize the operator's comfort and performance. All switches and controls are ergonomically positioned on the right side, easy to find and to reach; opening and closing the front window is easy with the one-touch lock release; and the extra wide door provides easy access.

A FULLY ADJUSTABLE WORKSTATION

The seat is adjustable in all directions, independently or with the side consoles. The armrests, integrated in the side consoles, can be placed in four different positions and inclined, enabling the operator to tailor the workstation for maximum convenience and comfort. The optional air-suspension seat with heated cushion can add further to the operator's comfort.

SUPERIOR OPERATOR ENVIRONMENT

Long working days will feel shorter with the new radio with Bluetooth and USB, and the automatic air-conditioning system.



LOW VIBRATION AND NOISE LEVEL

Six silicon liquid filled viscous dampers and enhanced soundproofing of the EVO cab result in remarkably low noise and vibration levels, adding to the operator's comfort and reducing fatigue.

OUTSTANDING VISIBILITY

The EVO cab provides excellent all-round visibility, with a full size right window and standard rear-view camera. The new standard skylight with sunshade provides a clear view to overhead obstacles.

EASY TO OPERATE

The new multifunctional monitor is easy to read with a full-color screen dedicated to the rear wide-angle camera (if option selected). The operator can set service interval reminders for engine oil, hydraulic oil, fuel and filters. The auxiliary hydraulics can be adjusted from the control monitor to match pressure and flow to the attachment. Self-diagnostics with fault code memory make it easy to check and adjust system pressures, engine speed, travel speed, hydraulic pressure and other operating functions. Work and attachment modes are easy to select and are clearly displayed on the monitor.

BUILT-IN SERVICEABILITY AND RELIA

DESIGNED TO CUT OPERATING COSTS

The side-by-side radiator layout improves cooling performance and is exceptionally easy to clean. Easy-to-change engine oil and fuel filters and ground access to all daily service points contribute to maximizing the machine's uptime.



SERVICE POINTS AT GROUND LEVEL

The engine oil filter, fuel filter and water separator, which removes contaminants and water, are key for good engine performance and durability. They are remote mounted and easy to reach from ground level for easy maintenance.



LONG LIFE HYDRAULIC OIL

The long-life hydraulic oil has excellent anti-emulsion characteristics as well as an optimized mix of anti-wear and anti-oxidants additives that extend service intervals to 5000 hours, resulting in an impressive reduction in operation costs and environmental impact.



CENTRALISED LUBRICATION

Grouped and centralised greasing points, allow all boom wear points to be easily greased from ground level at 500-hour service intervals.

MORE RELIABILITY AND DURABILITY WITH THE HEAVY DUTY DESIGN

Booms and arms were designed using advanced CAD and FEM (Finite Elements Methodology) Systems to maximize strength in those areas where stresses are concentrated. The result is a strong Heavy Duty front attachment that can deal with the toughest applications.



BUCKET LINKAGE WITH DOUBLE BUSHING

Additional external bushings made of anti-wear steel provide extra protection to the arm and bucket's long-life internal bushing. When the radial surface becomes worn, these bushings are easy to change, increasing pin and bushing durability while reducing operating costs.

ARM PROTECTION

An optional arm protection is available to further extend durability even in rocky applications.

BUILT TO LAST

The heavy-duty X-frame undercarriage is built to last, with rollers, sprockets and travel motors sealed for a long life. The two track frames come with a standard central mounted track guide. Four additional track guides are also available as an option for work in particularly uneven or rocky terrain. They help keep the chains on the rollers and protect them, ensuring greater durability, efficiency and safety.



E245C

SPECIFICATIONS



ENGINE TIER 3

Make and model FPT F4GE9684E
Engine Power (ISO 14396/ECE R120) 118 kW/160 hp (2000 rpm)
Maximum torque 665 Nm (1200 rpm)
Type diesel, direct injection, intercooler
Displacement 6.728 l
N. of cylinders 6
Bore x stroke 104 x 132 mm

Remote engine oil filter for easy replacement

Electronic engine rpm control, dial type

Auto-Idling selector returns engine to minimum rpm when all controls are in neutral position

Outside temperature start is standard equipment:

Hot climate (HME) version: -25°/+45°
Cold climate (CIS) version: -30°/+40°
The engine complies with 97/68/EC standards stage 3A/Tier3



ELECTRICAL SYSTEM

Voltage / Alternator 24 V / 70 A
Starter motor 4 kW
Maintenance-free batteries 2 x 12V/ 160 Ah



TRANSMISSION

Type hydrostatic, two-speed, Automatic DownShift
Travel motors axial piston type, double displacement
Brakes automatic discs type
Final drive oil bath, planetary reduction
Gradeability 70% (35°)
Travel speeds: low 0 - 3.7 km/h / high 0 - 5.7 km/h
Drawbar pull 241 kN



UNDERCARRIAGE

X-frame undercarriage design
Reinforced track chain with sealed bushing

E245C LC

Track rollers (each side)	9
Carrier rollers (each side)	2
Length of track on ground (mm)	3850
Gauge (mm)	1990
Shoes (mm)	600-700 800-900

Shoe type Tractor type triple grouser shoe
No. for each side 51
Height of grouser shoe 26 mm



HYDRAULIC SYSTEM

High capacity double pumps with electronic delivery adjustment.
Variable displacement pistons pumps revert in neutral automatically to zero. Main Control Valve with Fail Safe Function and Anti drift valve.

H.A.O.A. (Hydrotronic Active Operation Aid)
E.S.S.C. (Engine Speed Sensing Control)
D.O.C. (Dipper Optimised Control)
C.P.B. (Continuous Power Boost)

3 working Modes

H Mode - Heavy duty excavation work
S Mode - Standard digging and loading work
E Mode - Fuel Economy

Attachments Modes

A Mode - Auxiliary attachments (two-way auxiliary)
B Mode - Breaker (one-way auxiliary)
Attachments flow and pressure setting from cab, 18 presets storage

Hydraulic pump

Max flow at rated engine speed 2 x 220 l/min
Piloting circuit gear type pump max 20 l/min

Directional control valves

Type 8-spool valve

System Pressures

Boom, Arm&Bucket 34.3 MPa
with Power Boost 37.8 MPa
Swing 29 MPa
Pilot control Circuit 5MPa



CAPACITIES

Fuel tank 320 l
Hydraulic system (incl. 167 l tank) 255 l
Cooling system 24 l



SWING

Swing motor axial piston type
Swing brake hydraulic brake
Swing speed 0-12.8 rpm



CAB AND CONTROLS

Operator's cab

Structure Fully enclosed steel structure
EVO operator cabine evolution in comfort and opt. the safety cab
compliant to ROPS (ISO 12117-2)
and FOPS (ISO 10262 level II) optionals

Rear camera optional
Monitor integrated multi-function control monitor with integrated
rear view camera display (if option selected)

Operator's seat

Operator's seat Adjustable and reclining device

Operation

Engine control Rotary - type electric throttle
Travel Two hand levers or two foot pedals for
forward and backward operations of each track independently
Excavating and swing Two hand levers for four operations

DIMENSIONS - MONOBOOM

Boom length 5.65 m

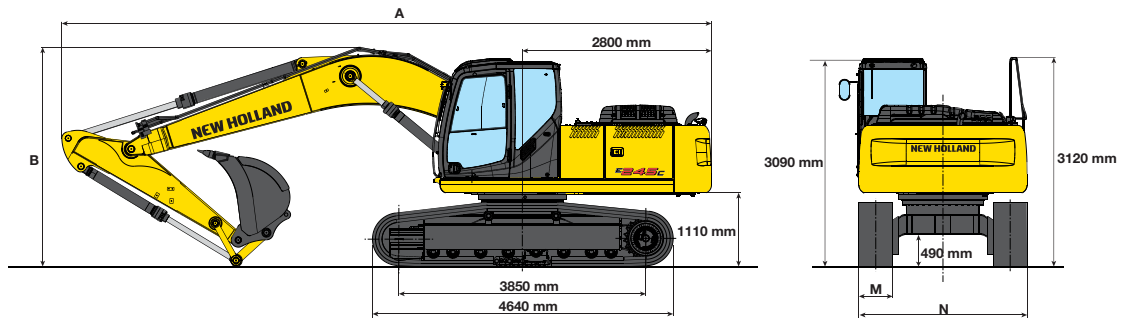

LCVERSION

ARM		2080	2400	2940	3500
A - Overall length	mm	9620	9580	9500	9570
B - Boom height in transport position	mm	3260	3160	2970	3160
Overall height	mm	3260	3160	3120	3160

OPERATING WEIGHT - MONOBOOM

		LCVERSION			
M - Shoe width	mm	600	700	800	900
N - Maximum width	mm	2990	3090	3190	3290
Operating weight*	kg	23300	23810	24120	24496
Ground pressure*	bar	52,6	46,1	40,9	36,9

* 2400 mm arm



E245C

DIGGING PERFORMANCE - MONOBOOM

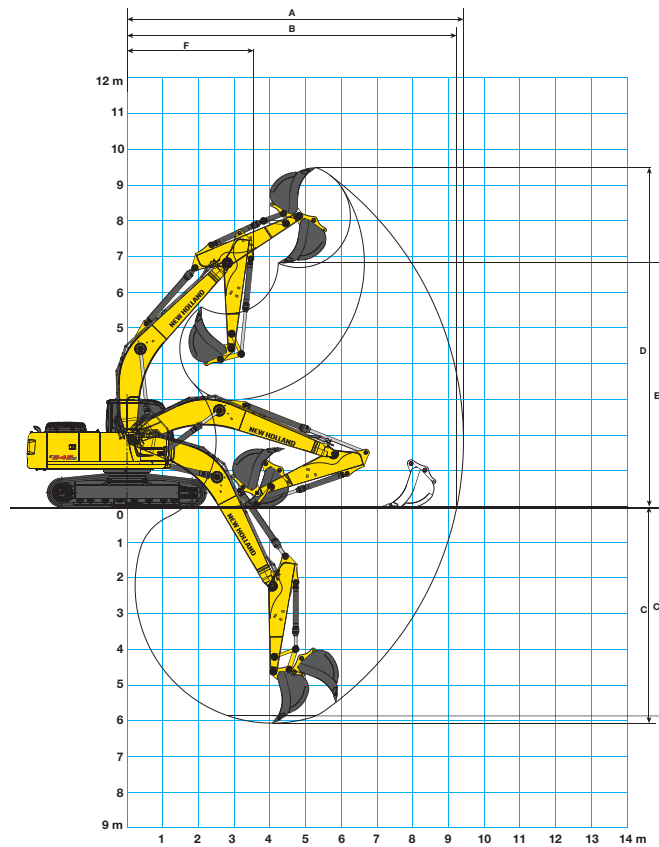

ARM		2080	2400	2940	3500
A - Max. digging reach	mm	9160	9430	9910	10350
B - Max. digging reach at ground level	mm	8970	9240	9730	10170
C - Max. digging depth	mm	5740	6070	6610	7170
C' - 2,4 mt level digging depth	mm	5521	5861	6427	6996
D - Max. digging height	mm	9420	9500	9710	9740
E - Max. dumping clearance	mm	6610	6700	6930	7170
F - Min. swing radius	mm	3670	3550	3530	3470

BREAKOUT FORCE

ARM		2080	2400	2940	3500
Bucket	daN	15500	15500	15500	15500
Dipperstick	daN	15200	13150	10900	9000

WITH "POWER BOOST" ON

ARM		2080	2400	2940	3500
Bucket	daN	16900	16900	16900	16900
Dipperstick	daN	16500	14250	11800	9800

BUCKETS			E245C LC			
Width (mm)	Capacity m ³ SAE J296 (ISO 7451)	Weight (kg)	Arm mm			
			2080	2400	2940	3500
750	0.52	505				
850	0.62	540				
1000	0.78	635				
1200	1.00	650				
1300	1.10	700				
1500	1.31	760				

General digging work (specific weight of material < 1.8 t/m³)

Slightly heavy digging work (specific weight of material < 1,5 t/m³)

E245C

LIFTING CAPACITY LCVERSION

MONO BOOM - DIPPERSTICK 2080 mm

HEIGHT	RADIUS OF LOAD												REACH m	
	1.5 m		3.0 m		4.5 m		6.0 m		7.5 m		AT MAX. REACH			
	FRONT	SIDE	FRONT	SIDE	FRONT	SIDE	FRONT	SIDE	FRONT	SIDE	FRONT	SIDE		
+7.5 m												6.4*	6.4*	5.2
+6.0 m							6.2*	6.2*				6.1*	6.1	6.4
+4.5 m			10.9*	10.9*	7.8*	7.8*	6.6*	6.6				6.1*	5.1	7.2
+3.0 m					9.4*	9.3	7.3*	6.3	6.2*	4.7		6.2*	4.6	7.6
+1.5 m					10.7*	8.8	7.9*	6.1	6.5*	4.6		6.4*	4.5	7.7
0 m					11.0*	8.6	8.2*	5.9				6.6*	4.6	7.4
-1.5 m			13.5*	13.5*	10.5*	8.6	7.9*	5.9				6.8*	5.0	6.9
-3.0 m			11.9*	11.9*	9.1*	8.8						6.9*	6.2	5.9
-4.5 m												6.3*	6.3*	4.2

MONO BOOM - DIPPERSTICK 2940 mm

HEIGHT	RADIUS OF LOAD												REACH m		
	1.5 m		3.0 m		4.5 m		6.0 m		7.5 m		AT MAX. REACH				
	FRONT	SIDE	FRONT	SIDE	FRONT	SIDE	FRONT	SIDE	FRONT	SIDE	FRONT	SIDE			
+7.5 m												4.2*	4.2*	6.3	
+6.0 m												5.3*	5.3*	7.4	
+4.5 m												5.8*	5.8*	8.0	
+3.0 m					12.9*	12.9*	8.3*	8.3*	6.6*	6.4	5.7*	4.7	3.5*	3.5*	8.4
+1.5 m					7.1*	7.1*	9.9*	9.0	7.4*	6.1	6.1*	4.6	3.8*	3.8*	3.5
0 m					8.4*	8.4*	10.8*	8.6	8.0*	5.9	6.4*	4.4	4.4*	4.0	8.3
-1.5 m	7.7*	7.7*	11.7*	11.7*	10.8*	8.5	8.1*	5.8	6.3*	4.4		5.3*	4.2	7.7	
-3.0 m	11.3*	11.3*	14.1*	14.1	10.0*	8.6	7.5*	5.8				6.3*	4.9	6.9	
-4.5 m			11.0*	11.0*	8.0*	8.0*						6.4*	6.4*	5.5	

MONO BOOM - DIPPERSTICK 2400 mm

HEIGHT	RADIUS OF LOAD												REACH m	
	1.5 m		3.0 m		4.5 m		6.0 m		7.5 m		AT MAX. REACH			
	FRONT	SIDE	FRONT	SIDE	FRONT	SIDE	FRONT	SIDE	FRONT	SIDE	FRONT	SIDE		
+7.5 m												5.8*	5.8*	5.6
+6.0 m							5.8*	5.8*				4.7*	4.7*	6.8
+4.5 m					7.3*	7.3*	6.3*	6.3*	4.9*	4.8		4.8*	4.8*	7.5
+3.0 m					9.0*	9.0*	7.0*	6.3	6.0*	4.7		5.0*	4.4	7.9
+1.5 m					10.4*	8.9	7.7*	6.1	6.4*	4.6		5.5*	4.2	8.0
0 m			7.6*	7.6*	11.0*	8.7	8.1*	5.9	6.5*	4.5		6.3*	4.3	7.8
-1.5 m	8.6*	8.6*	12.7*	12.7*	10.7*	8.6	5.9*	8.0				6.5*	4.7	7.2
-3.0 m	13.4*	13.4*	13.0*	13.0*	9.6*	8.7	7.1*	5.9				6.7*	5.6	6.3
-4.5 m			9.3*	9.3*	6.9*	6.9*						6.5*	6.5*	4.7

MONO BOOM - DIPPERSTICK 3500 mm

HEIGHT	RADIUS OF LOAD												REACH m		
	1.5 m		3.0 m		4.5 m		6.0 m		7.5 m		AT MAX. REACH				
	FRONT	SIDE	FRONT	SIDE	FRONT	SIDE	FRONT	SIDE	FRONT	SIDE	FRONT	SIDE			
+7.5 m														6.8	
+6.0 m												3.7*	3.7*	7.8	
+4.5 m												5.2*	5.2*	8.5	
+3.0 m					10.8*	10.8*	7.4*	7.4*	6.0*	6.0*	5.3*	4.6	3.1*	3.1*	8.8
+1.5 m					10.7*	10.7*	9.2*	9.0	6.9*	6.0	5.8*	4.5	3.4*	3.4*	8.9
0 m	4.2*	4.2*	9.2*	9.2*	10.4*	6.3	7.6*	5.8	6.1*	4.3		3.8*	3.6	8.7	
-1.5 m	7.0*	7.0*	11.3*	11.3*	10.7*	8.4	7.9*	5.7	6.2*	4.2		4.6*	3.8	8.2	
-3.0 m	10.0*	10.0*	14.9*	14.9*	10.3*	8.4	7.6*	5.6				5.9*	4.3	7.4	
-4.5 m	13.7*	13.7*	12.4*	12.4*	8.8*	8.5	6.4*	5.8				3.7*	3.7	6.1	

All the lift capacity values are in tonnes and without bucket

As per ISO 10567 the indicated load is no more than 87% of hydraulic system lifting capacity or 75% of static tipping load. Values marked with an asterisk are limited by the hydraulic system.

PARTS AND SERVICE

The New Holland dealer network is, in itself, the best guarantee of continued productivity for the machines it delivers to its customers. New Holland service technicians are fully equipped to resolve all maintenance and repair issues, with each and every service point providing the high standards they are obliged to observe under New Holland's stringent quality guidelines.

The New Holland global parts network ensures fast, reliable, replacement parts for less downtime, increased productivity and, of course, profitable operation for its customers.



AT YOUR OWN DEALERSHIP

The information contained in this brochure is intended to be of general nature only. The NEW HOLLAND CONSTRUCTION MACHINERY S.p.A. company may at any time and from time to time, for technical or other necessary reasons, modify any of the details or specifications of the product described in this brochure. Illustrations do not necessarily show products in standard conditions. The dimensions, weights and capacities shown herein, as well as any conversion data used, are approximate only and are subject to variations within normal manufacturing techniques.

Printed in Italy - MediaCross Firenze - Cod AP4309NCGB - Printed 10/14

Printed on recycled paper
CoC-FSC 000010 CQ Mixed sources



ELEMENTAL
CHLORINE
FREE
GUARANTEED



BUILT AROUND YOU

WWW.NEWHOLLAND.COM