

D – SERIES MINI EXCAVATOR

E17D / E19D/ E25D/ E35D / E50D / E58D



**SMALL IN SIZE.
BIG ON PERFORMANCE.
HUGE IN VERSATILITY.**



VERSATILE AND EXCEPTIONALLY PRODUCTIVE.

Suiting applications from track, irrigation and drainage scheme construction and maintenance through to fencing, temporary building creation and crop support erection, New Holland mini crawler excavators have a operating weight range from 1.7 to 6 tonnes.

By offering a line which covers the whole mini excavator category, the new D-series answers all your needs. With a choice of 5 models, there is one for every application across landscaping, amenity work, agriculture, horticulture, nurseries, vineyards, estate management and general contracting.

The new D-series mini excavators are designed to work efficiently in every condition, outperforming the competition in terms of dump clearance and maximum reach. All models are feature a compact tail design allowing work in the tightest spaces – across the range seven models are zero tail swing types and the remaining seven are short radius versions.

Small in size. Big on performance. Huge in versatility.

Compact dimensions enable New Holland mini excavators to access and work in confined spaces. Yet those dimensions are matched to high performance that will impress you. Designed for day-long working, each model has class-leading excavation performance with the versatility to power a wide range of attachments.

MODELS		E17D	E19D	E25D	E35D	E50D	E58D
Max. rated power	kW/hp	12/16.1	13.7/18.4	13.7/18.4	18.2/24.7	45/60.3	44.3/59.4
Operating weight with Canopy/Cab ISO 6016	kg	1690/1800	1880/1990	2580/2710	-/3400	-/4950	-/5670
Maximum width	mm	990 - 1250	990 - 1300	1500	1580	1900	1980
Overall height	mm	2370		2527	2530	2570	2550
Rear rotation radius	mm	650		750	790	950	1000
Max. digging depth Std/ Opt arm	mm	2020/2220	2280/2480	2700/2900	2870/3070	3330/3580	3400/3570
Max. dumping height Std/ Opt arm	mm	2340/2460	2580/2700	3330/3460	3110/3230	3920/4080	3950/4050

- Not available * with roll-bar and FOPS | roof ISO 6016









E17D & E19D THE PERFECT BALANCE BETWEEN AGILITY AND PERFORMANCE.

Thanks to their variable undercarriage, E17D, and E19D can pass through spaces as narrow as just 99 centimetres, without compromising stability once the undercarriage is fully extended before starting work.



OVERALL MACHINE WIDTH (MM)	E17D	E19D
Retracted undercarriage	990	990
Extended undercarriage	1250	1300



Easy to transport

We know that a machine is profitable when you spend as much time as possible working with it. To transport New Holland mini excavators quickly from one jobsite to another, the self-supporting canopy allows you to quickly and safely load the machine onto a truck or trailer. Convenient tie-down points and mechanical locking of the slewing enable the machine to be secured for transport in just a few minutes.



Cab or canopy: your choice

The models in the New Holland compact excavator range are available either with canopy or cab. On E17D and E19D, the cab does not compromise the zero tail swing design. This short radius model features an XXL cab, yet retains the variable undercarriage. All D-series models in this weight class stand out thanks to stylish and convenient operator stations with nice multicolour clusters, a smart front window opening system and plenty of storage space including a practical cell-phone carrier.



Mulching kings

E19D can be equipped with the High Flow option, which provides a significant advantage for applications such as mulching with a flail head. Effective mulching requires a constant hydraulic flow to the tool, particularly when simultaneously travelling and moving the arm - and this is exactly what the High Flow option delivers.



Maintenance made easy

Keeping maintenance easy is one of our missions! You will find easy access to all components thanks to the tiltable cab and canopy.

E25D & E35D AT EASE ON ALL TERRAINS.

With the ideal weight for transportation, E25D and E35D are the perfect machines to travel swiftly to the next task. These models are all of a zero tail swing design, representing a winning combination of compact size and strong working capabilities.





To begin with... precision

These New Holland excavators feature an advanced load sensing hydraulic system with a flow sharing distributor. As a result, power is available on demand and simultaneous movements are optimized. Hydraulic attachments can easily be operated directly from the joysticks with the 1st and 2nd proportional auxiliary controls, and a 3rd auxiliary circuit is available on demand. The unique high-flow option is the right choice when mulching is the main application.



Tailor-made minis

The full potential of E25D and E35D can be exploited when it is equipped with a full array of attachments: not just digging or ditch cleaning buckets, but also earth augers, sorting grabs, wood grapples, mulchers, hammers and much more. And to easily change the different attachments, mechanical or hydraulic quick couplers are a real help.



360° visibility

D-series mini excavators have been designed to offer a high level of comfort. All-round visibility is afforded by a large glazed area, a panoramic sky window and a powerful LED lights package.



Comfort pays off

On E35D, comfort can be further enhanced by upgrading with an array of optional features, such as air conditioning, electric refuelling pump, pneumatic seat, DAB radio with Bluetooth and many others. Operators who feel comfortable while working are more productive and work in a safer way too.



Peace of mind

D-Series minis are extremely reliable machines, designed for a long life provided that regular maintenance is properly done. For this reason, service access is intuitive and convenient. The cab can be quickly tilted, providing excellent access to the heart of the machine. Refuelling is simpler on D-series mini excavators: the unique location of the fuel tank in the rear hood makes the process extremely easy and releases space in the engine compartment for even better maintenance accessibility.



A personalized machine

To customize your D-series mini excavator for different jobs where extra stability is key, additional counterweights can easily be bolted on the rear of the machine. And if it is to be used to lift heavy objects, a certified object handling kit, which includes safety check valves, lifting capacity diagrams and an acoustic overload alarm, is available as option.

E50D & E58D

STYLISH AND VERSATILE.

The D-series range counts three zero tail swing models, E50D and E58D.

These machines feature an electronically controlled engine combined with an efficient load-sensing hydraulic system. The array of performance and comfort features available is comprehensive, and includes automatic air conditioning, front and rear LED lights, pneumatic suspension seats, integrated rearview camera, electric fuel refill pump, dozer float function, 6x1 dozer blade and many more.





Extremely silent

Extremely silent and powerful Stage V engines allow for work in the most challenging conditions. Not only do these models excel in terms of engine power and torque, but they are also extremely silent thanks to the hydraulic fan-drive cooling system. The fan speed is electronically controlled, so that heat exchange is optimized while noise level is kept to a minimum, since fan rotation speed is adjusted depending on the real time cooling needs. The fan can even rotate in inverted direction, enabling to keep radiators clean at all times. An efficient cooling system contributes to keeping fluid properties within parameters, maximising machine component life.

Embedded innovation

The 7" multicolour display allows customization of several parameters, including flow rate settings for the auxiliary circuits, the fan drive automatic reversal interval, the auto-idle, sensitivity of the controls, the cab ventilation and many others. The display also acts as a self-diagnostic tool, reminding the operator when maintenance is due and keeping machine health parameters under control at all times.



Easy maintenance

As on all the smaller models of the D-series, E50D and E58D have been designed to allow quick maintenance tasks: the engine hood, the radiator cover, the rear cover, the distributor guard and the fuse compartment guard can all easily be removed or opened, granting perfect accessibility to all service components. What's more, the cab can easily be tilted forward, providing maximum accessibility to all machine components.

SPECIFICATION

MODELS		E17D	E19D
ENGINE			
Type		Yanmar 3TNV70 - Stage V	Yanmar 3TNV76 - Stage V
Max. Power (2200rpm)	kW/hp	12/16.1	13.7/18.4
Displacement	cm ³	854	1116
Number of cylinders	n°	3	3
Cooling		Liquid	Liquid
Consumption	l/h	2.4	3.1
Alternator	V Ah	12 (40)	12 (40)
Battery	V Ah	12 (65)	12 (65)
HYDRAULIC SYSTEM			
Pump type		variable flow	variable flow
Pump displacement	cm ³	8 + 8 + 6.6	9 + 9 + 6.6
Pump capacity	l/min	16 + 16 + 13.1	18 + 18 + 13.1
Max. circuit calibration pressure	bar	220	240
Auxiliary system (max pressure):			
AUX 1 - single or double effect	l/min / bar	29.1 / 205	31.1 / 205
AUX 2 - optional	l/min / bar	13.1 / 205	13.1 / 205
AUX 3 - optional	l/min / bar	16 / 220	18 / 240
SLEWING & TRAVEL SPEED			
Travelling speed (AUTO TWO SPEED)	km/h	1st : 0 + 2.2 / 2nd : 0 + 4.1	1st : 0 + 2.3 / 2nd : 0 + 4.4
Slew speed	rpm	10.5	10.5
CONTROLS			
Boom, dipper stick, bucket and turret swing		2 pilot joysticks	2 pilot joysticks
Positioner two pieces boom		-	-
Track movements (included counter rotation)		2 mechanical levers	2 pilot levers
Dozer blade		pilot lever	pilot lever
Auxiliary system with latch AUX 1 (single or double effect)		right pedal	electroproportional switch on right joystick
Boom swing		left pedal	electroproportional switch on left joystick
WEIGHTS			
Transport weight with roll-bar*	kg	-	-
Transport weight with roll-bar and FOPS 1 roof*	kg	-	-
Operating weight with roll-bar* ISO 6016	kg	-	-
Operating weight with roll-bar and FOPS 1 roof* ISO 6016	kg	-	-
Transport weight with canopy*	kg	1580	1770
Transport weight with cab*	kg	1690	1880
Operating weight with canopy* ISO 6016	kg	1690	1880
Operating weight with cab* ISO 6016	kg	1800	1990
* with rubber tracks			
CIRCUIT AND COMPONENT CAPACITIES			
Fuel tank	l	25	25
Hydraulic oil tank	l	20	20
Hydraulic circuit capacity	l	29	29
Cooling system capacity	l	4.5	4.5
Engine oil	l	2.4	2.8

MODELS		E25D	E35D	E50D	E58D
ENGINE					
Type		Yanmar 3TNV76 - Stage V	Kubota D1703-M-DI-E4B - Stage V	Perkins 404J-E22T - Stage V	Kubota -V2607-CR-T - Stage V
Max. Power (2200rpm)	kW/hp	13.7/18.4	18.2/24.7	45/60.3	44.3/59.4
Displacement	cm ³	1116	1647	2216	2615
Number of cylinders	n°	3	3	4	4
Cooling		Liquid	Liquid	Liquid	Liquid
Consumption	l/h	3	3.5	7.1	7.6
Alternator	V Ah	12 (40)	12 (40)	12 (85)	12 (60)
Battery	V Ah	12 (65)	12 (74)	12 (100)	12 (95)
HYDRAULIC SYSTEM					
Circuit Type		Load Sensing closed center system with "Flow Sharing" control valve			
Pump type		1 LS variable pump	1 LS variable pump + 1 gear pump	1 LS hydraulic variable pump with electronic control + 1 gear pump	
Pump displacement	cm ³	25	48 + 5	65 + 14.5	65 + 14.5
Pump capacity	l/min	52	105 + 10	129 + 28.8	129 + 28.8
Max. circuit calibration pressure	bar	240	250	280	280
Auxiliary system (max pressure):					
AUX 1 - single or double effect with priority	l/min / bar	45 / 210	50 / 200	70 / 200	80 - 200
AUX 2 - optional	l/min / bar	18 / 200	35 / 20-250	-	-
AUX 2 - double effect - optional	l/min / bar	-	-	40/30 / 280	60/40 - 280
AUX 2 - double effect	l/min / bar	-	-	-	-
AUX 3 - optional	l/min / bar	46 / 210	35 / 20-250	40/30 / 280	37 - 280
AUX 3 - double effect - optional	l/min / bar	-	-	-	-
SLEWING & TRAVEL SPEED					
Travelling speed (AUTO TWO SPEED)	km/h	1st : 0 ÷ 2.6 / 2nd : 0 ÷ 4.3	1st : 0 ÷ 2.5 / 2nd : 0 ÷ 4.6	1st : 0 ÷ 2.6 / 2nd : 0 ÷ 4.5	1st : 0 ÷ 2.5 / 2nd : 0 ÷ 4.5
Slow speed	rpm	11	11	10.5	11
Controls					
Boom, dipper stick, bucket and turret swing		2 pilot joysticks	2 pilot joysticks	2 pilot joysticks	2 pilot joysticks
Track movements (included counter rotation)		2 pilot levers	2 pilot levers	2 pilot levers	2 pilot levers
Dozer blade		pilot lever	pilot lever	pilot lever	pilot lever
Priority auxiliary system with holding function					
AUX 1 (single or double effect)		electroproportional switch on right joystick	electroproportional switch on right joystick	electroproportional switch on right joystick	
Auxiliary system AUX 2 (double effect)		-	electroproportional switch on left joystick	electroproportional switch on right joystick	-
Auxiliary system AUX 3 (double effect)		-	-	electroproportional switch on left joystick	-
Boom swing		electroproportional switch on left joystick			
WEIGHTS					
Operating weight with canopy* ISO 6016	kg	2580	3270	-	-
Operating weight with cabin* ISO 6016	kg	2710	3400	4950	5440
Transport Weight with canopy	kg	2450	3120	-	-
Transport Weight with cab	kg	2580	3250	4800	5670
* with rubber tracks					
CIRCUIT AND COMPONENT CAPACITIES					
Fuel tank	l	26	45	75	85
Hydraulic oil tank	l	29	30	65	60
Hydraulic circuit capacity	l	40	54	85	80
Cooling system capacity	l	5	7.5	11	12
Engine oil	l	2.8	7	9.5	10.2

SPECIFICATION

MODELS		E17D	E17D	E25D	E25D	E35D
Performance data		Arm Std.	Arm Opt.	Arm Std.	Arm Opt.	Arm Std.
Arm length	mm	950	1150	1350	1550	1200
Max. digging depth	mm	2020	2220	2700	2900	2870
Max. dumping height	mm	2340	2460	3330/3190	3460/3310	3110
Bucket breaking force	daN	1500	1500	2200	2200	3100
Arm breaking force ISO 6015	daN	1080	950	1450	1450	1750
Traction force	daN	1700	1700	2200	2200	3400
Ground bearing pressure with canopy (ABS roof)	kg/cm ²	–	–	–	–	–
Ground bearing pressure with rubber tracks and canopy (with cabin)	kg/cm ²	0.30-0.31	0.31-0.33	0.28-0.29	0.28-0.29	0.33 (0.34)
Max. slope		60% - 30°	60% - 30°	60% - 30°	60% - 30°	60% - 30°

MODELS		E19D	E19D	E50D	E50D	E58D	E58D
Performance data		Arm Std.	Arm Opt.	Arm Std.	Arm Opt.	Arm Std.	Arm Opt.
Arm length	mm	1150	1350	1500	1750	1500	1650
Max. digging depth	mm	2280	2480	3330	3580	3400	3570
Max. dumping height	mm	2580	2700	3920	4080	3950	4050
Bucket breaking force	daN	1500	1500	4300	4300	5300	5300
Arm breaking force ISO 6015	daN	950	950	2350	2350	2800	2800
Traction force	daN	1860	1860	5420	5420	5500	5500
Ground bearing pressure with canopy (ABS roof)	kg/cm ²	–	–	–	–	–	–
Ground bearing pressure with rubber tracks and canopy (with cabin)	kg/cm ²	0.31-0.32	0.3-0.32	0.28	0.28	0.31	0.31
Max. slope		60% - 30°	60% - 30°	60% - 30°	60% - 30°	60% - 30°	60% - 30°

MODELS		E17D	E19D	E25D	E35D	E50D	E58D
General dimensions							
Maximum width	mm	990 - 1250	990 - 1300	1500	1580	1900	1980
Total height	mm	2370	2370	2527	2530	2570	2550
Tracks width	mm	230	230	280	300	400	400
Rear rotation radius	mm	650	650	750	790	950	1000
Digging arm length standard (optional)	mm	950-1150	1150-1350	1350-1550	1200 (1400)	1500-1750	1500-1650
Rollers number (for each side)	n°	3	3	4/1	4/1	5/1	5/1

LIFTING CAPACITY

E17D	2	3	Max
Frontal and lowered dozer blade	720* (630*)	480* (450*)	460* (420*)
Frontal and lifted dozer blade	300 (360)	160 (190)	150 (160)
Lateral, open undercarriage	340 (400)	190 (210)	170 (180)

Standard dipper stick L = 950 mm
(Optional dipper stick L = 1150 mm)

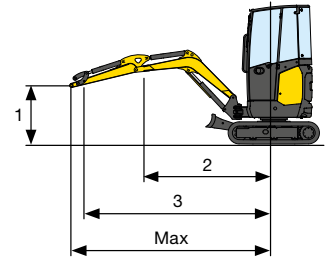

E19D	2	3	Max
Frontal and lowered dozer blade	610*	420*	390*
Frontal and lifted dozer blade	430	230	180
Lateral, open undercarriage	430	230	190

Standard dipper stick L = 1150 mm
(Optional dipper stick L = 1350 mm)

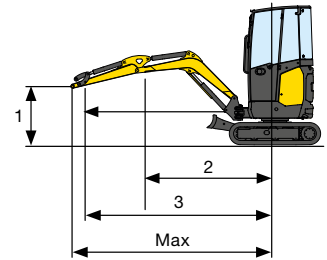

E25D	2	3	4	Max
Frontal and lowered dozer blade	1040*	550*	420*	410*
Frontal and lifted dozer blade	750	420	260	240
Lateral, open undercarriage	790	440	280	270

Standard dipper stick L = 1350 mm
(Optional dipper stick L = 1550 mm)

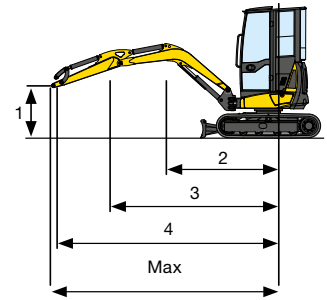

E35D	3	4	Max
Frontal and lowered dozer blade	870*	650*	630*
Frontal and lifted dozer blade	870*	650*	630*
Lateral, open undercarriage	690	470	430

Standard dipper stick L = 1200 mm
(Optional dipper stick L = 1400 mm)

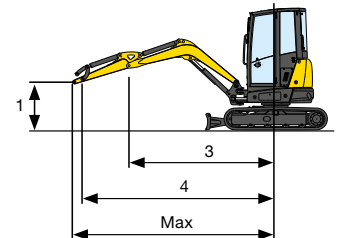

CX50D	3	4	Max
Frontal and lowered dozer blade	1830*	1280*	1090*
Frontal and lifted dozer blade	1260	820	610
Lateral, open undercarriage	930	620	460

Standard dipper stick L = 1500 mm
(Optional dipper stick L = 1750 mm)

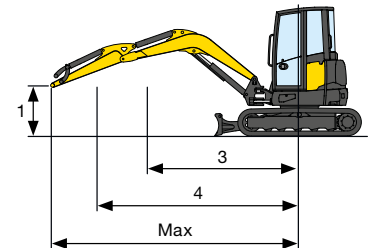

E58D	3	4	5	Max
Frontal and lowered dozer blade	2740*	1820*	1430*	1390*
Frontal and lifted dozer blade	1490	980	700	680
Lateral, open undercarriage	1290	860	620	590

Standard dipper stick L = 1500 mm
(Optional dipper stick L = 1650 mm)

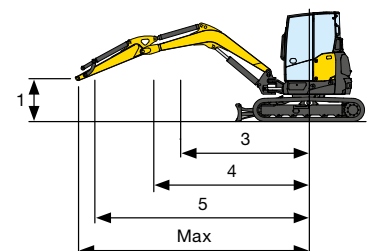

* Indicates the hydraulic load limit.

The lifting capacity is based on the ISO 10567 and it does not exceed more than the 75% of static tipping load or more than the 87% of the hydraulic lifting capacity of the machine.



The New Holland dealer network is, in itself, the best guarantee of continued productivity for the machines it delivers to its customers. New Holland service technicians are fully equipped to resolve all maintenance and repair issues, with each and every service point providing the high standards they are obliged to observe under New Holland's stringent quality guidelines. The New Holland global parts network ensures fast, reliable, replacement parts for less downtime, increased productivity and, of course, profitable operation for its customers.

Learn more at www.newholland.com

Printed on recycled paper
CoC-FSC 000010 CQ Mixed sources



AT YOUR OWN DEALERSHIP

The information contained in this brochure is intended to be of general nature only. The NEW HOLLAND CONSTRUCTION MACHINERY S.p.A. company may at any time and from time to time, for technical or other necessary reasons, modify any of the details or specifications of the product described in this brochure. Illustrations do not necessarily show products in standard conditions. The dimensions, weights and capacities shown herein, as well as any conversion data used, are approximate only and are subject to variations within normal manufacturing techniques.