

# D125C D150C D180C

SCR  
INSIDE



	D125C	D150C	D180C
<b>MAX. POWER</b>	100 kW/134 hp	121 kW/162 hp	169 kW/226 hp
<b>RATED POWER</b>	92 kW/123 hp	111 kW/149 hp	156 kW/210 hp
<b>UNDERCARRIAGE CONFIGURATION</b>	LT, WT, LGP	XLT, WT, LGP	LT, XLT, WT, LGP



**BUILT AROUND YOU**

# AS LONG AS WE KEEP BUILDING ROADS, THERE WILL ALWAYS BE A JOURNEY TO UNDERTAKE

**“SCR”  
PRODUCTIVITY:  
-10% FUEL  
CONSUMPTION**

**“HYDROSTATIC”  
FLEXIBILITY: +19%  
PERFORMANCE**

**FULLY INTEGRATED  
ELECTRONICS  
SOLUTIONS:  
BEST-IN-CLASS  
DRIVING COMFORT**

**GROUND LEVEL  
ACCESS:  
QUICK AND EASY  
MAINTENANCE**

**FLEET FORCE:  
PERFECT FLEET  
MANAGEMENT**



# “SCR” PRODUCTIVITY

**-10% FUEL**

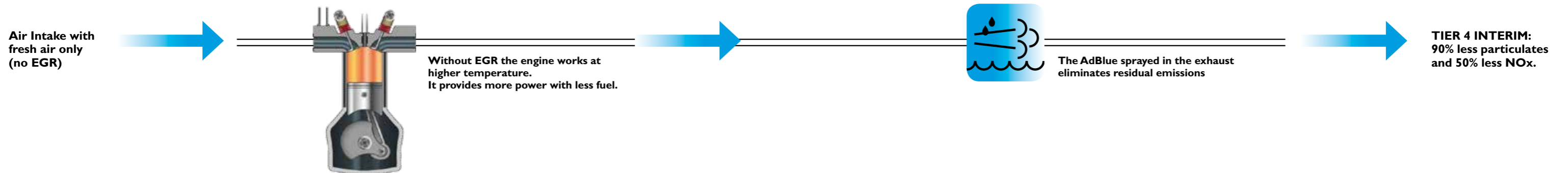
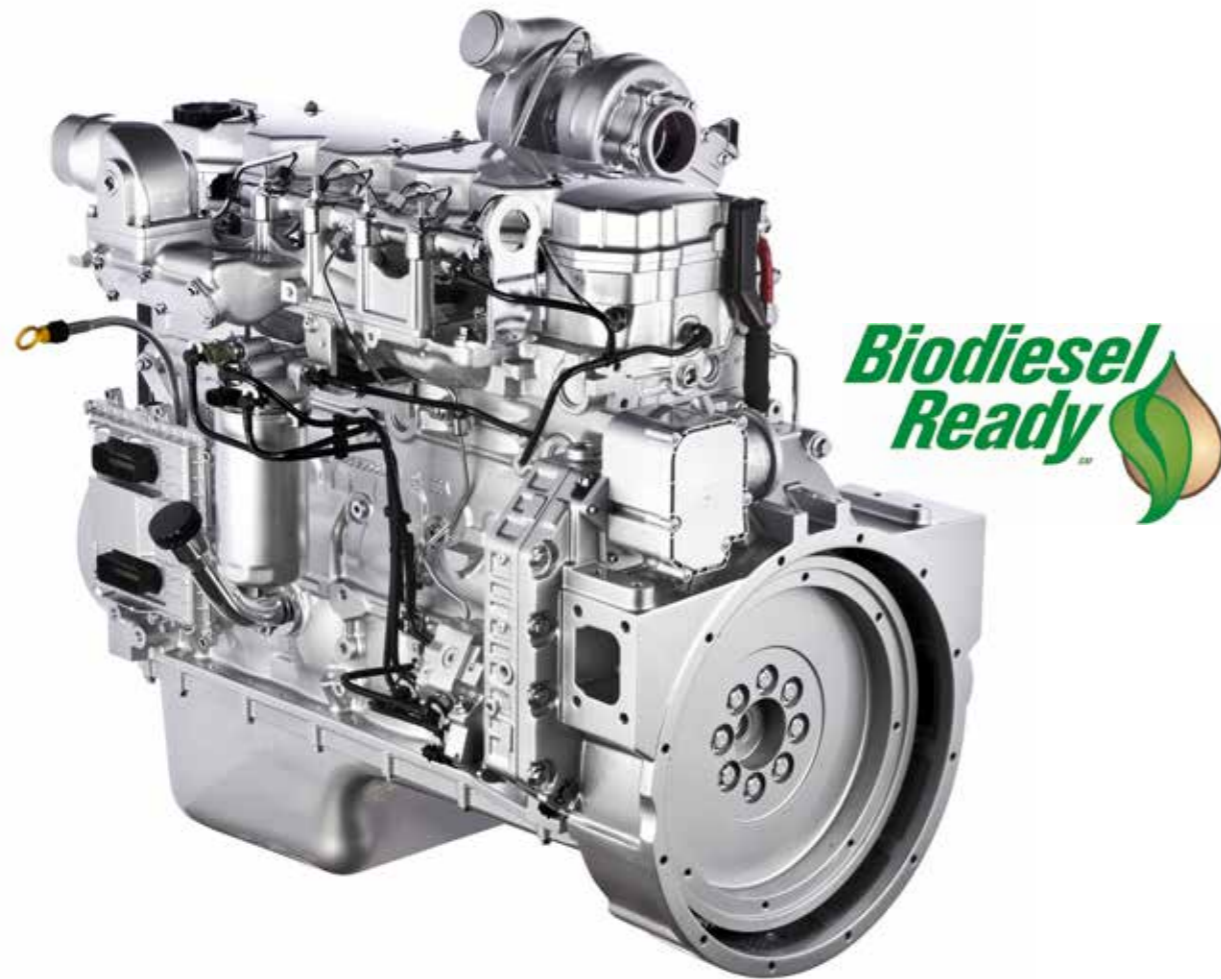

## FROM THE INDUSTRIAL ENGINE LEADER

- Fiat invented the «Common Rail» technology in the 80s
- New Holland is part of Fiat Industrial, which produces over 600.000 industrial engines per year
- Our engines are used not only in earthmoving equipment but also in trucks, agricultural equipments, marine and military applications
- These massive production volumes and our substantial investments in R&D enable us to bring you our “SCR only” solution, a unique and well proven technology that will drive down your operating costs
- Our engines are approved to run with 20% biofuel blends, reducing even more their enviromental impact

## SIMPLY MORE POWER AVAILABLE

- With “SCR only” engine combustion is more efficient: it only uses fresh air and occurs at high temperature, guaranteeing the best engine output for power and fuel efficiency.
- The second generation common rail technology with multiple injection reduces the vibrations transmitted to the operator
- The hydrostatically driven fan (d150C and D180C) supplies air flow only when required, saving power and reducing noise

## ”SCR ONLY”

- The most effective solutions are simple: “SCR ONLY” doesn’t use Exhaust Gas Recycling or Particulate Filter
- The cylinder burns fresh air only at higher temperature. It provides more power performances with less fuel
  - SCR cuts emissions by spraying AdBlue, a low cost fluid, into the exhaust system.
  - With SCR all the fuel is used to provide pushing power and none is needed to clean filters

## UNIQUE «SCR» DOZER

- **Fuel saving:** up to 10%
- **Efficiency:** up to 19% (in combination with new hydrostatic transmission)
- **Safety:** SCR is a safe solution because it works at low temperature and kills sparks in the exhaust
- **Ease of use:** SCR does not require any regeneration, the operator doesn’t have to follow any cleaning cycle
- **More uptime:** SCR doesn’t use a filter, so you don’t have to replace it periodically
- **Reliability:** SCR is a well proven solution introduced by Iveco since 2004.

# HYDROSTATIC FLEXIBILITY

**+19% EFFICIENCY**

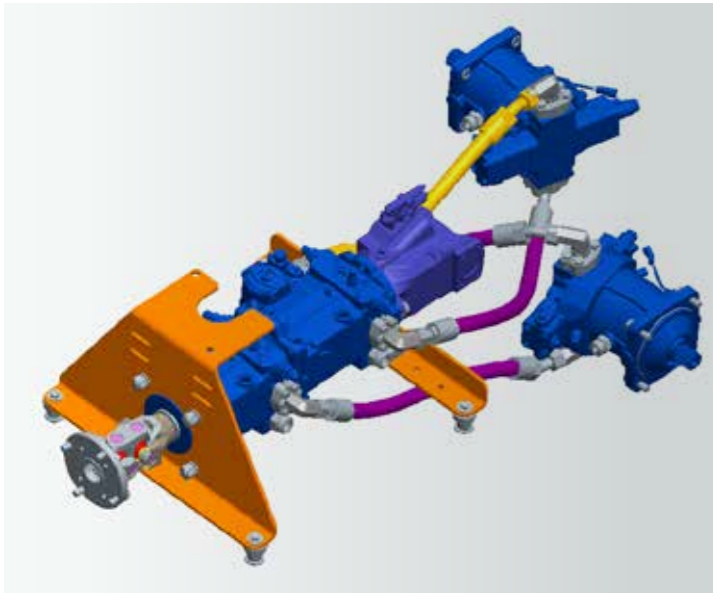

## “DUAL PATH” LAYOUT

The hydrostatic ensures power is always provided with the right amount of torque needed for the job, avoiding track slippage. The engine rpm is virtually disconnected from the transfer speed. The dozer can easily turn under load for higher productivity. Having fewer components than a standard solution, maintenance is faster, easier and cheaper.



## PROPORTIONAL DOZER CONTROL

The exclusive Proportional Dozer Control (PDC) function delivers best-in-class speed controllability. Having set the desired speed range (chosen among a 15 patterns), the operator can modulate dozer movements simply by moving the joystick forward or back. The PDC ensures smooth movements for better fine grading work and more comfortable operation. The operator can also choose from three reversing and turning reaction speeds for greater productivity and comfort.



## TRIPLE REDUCTION FINAL DRIVES

The triple reduction final drive adds a planetary reduction to the standard double one. With this solution the hydrostatic transmission can work at faster speed reducing the overall pressure and consequently the effort on the single components. The two final drives are directly flanged on the main frame for better effort distribution and easy disassembling in case of extraordinary maintenance.



## “ADVANCED LIFE TRACKS”

For toughest conditions New Holland can offer ALT tracks. This exclusive solution replaces the standard lubricated tracks and can double the life of the undercarriage reducing the total cost of ownership of the new “C series” dozer. All New Holland shoes have a specific clipped profile to reduce steering effort and soil damage.



## “ONE PIECE” MAINFRAME

All the vital dozer components such as the engine and transmission are mounted and integrated inside the new frame. All the typical dozer efforts are equally distributed reducing component wear and ensuring years of excellent performances. The modular assembly results in faster service and checks.

# COMFORTABLE CAB



## CONTROLS AT YOUR FINGERTIPS

You will enjoy the comfort of the heated seat with high vibration absorption. You can focus entirely on the job at hand and work comfortably with the two joysticks. The control panel is positioned ergonomically in front of you. The hydrostatic and hydraulic functions are enabled simply with two buttons, and there are no levers you need to engage. The powerful air conditioning system placed on the rear of the cab in a dust free place maintains an ideal internal climate at all times through multiple air vents.

## BEST-IN-CLASS BLADE CONTROLLABILITY

The blade functions and ripper are placed on the right hand console. The ripper can be easily controlled with the new joystick. The re-designed blade control offers new features that improve operator comfort and productivity: the Grading function instantly reduces oil flow by 50% for accurate blade contour; the Automatic shaking feature shakes sticky materials off the blade. Three reaction patterns (fast/medium/slow), blade speed and reversing sensitivity can be set on the on-board computer. The C Series can also be ordered Laser/GPS guidance ready, with factory fitted wiring components. You can choose the blade configuration you need: PAT, straight bulldozer or Semi-U bulldozer, as well as your preferred controls supplier.

## EASY TRANSPORT

For machines (D150C, D180C) fitted with PAT blades, a foldable version is available that reduces transport width to 3 meters for easy transportation without special permits.

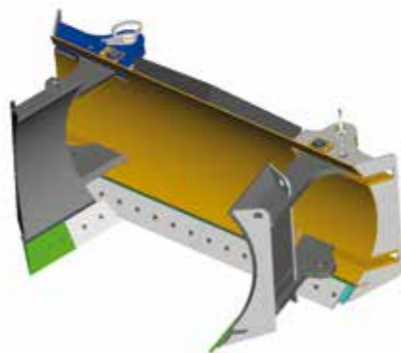

# EASY MAINTENANCE



## EXTENDED CLEANING INTERVALS WITH REVERSIBLE RADIATORS FAN

The "V shaped" cooling package leaves free space around the radiator, so that the cooling surface is exposed and it is easy to clean all the parts (intercooler, liquid cooler and oil cooler). Because the radiators are not overlapped the reversible fan cleans the coolers more effectively and keeps them working more efficiently even in very dusty conditions. The reversible fan can be activated manually or automatically and provides air flow only when required.

## LESS MAINTENANCE

For faster Return on investment all the main maintenance intervals have been extended resulting in higher uptime:  
**Hydraulic/Hydrostatic oil and filters: 2.000 hrs - Engine oil and filter: 500 hrs - Engine coolant: 2.000 hrs**



The filters, hydraulic oil level, pressure checks and main control valve can be easily reached from the ground on the right side of the machine.



All the electric components are grouped on the left hand side: batteries, fuse box and main electric switch are within easy reach. The two lateral panels are secured by a locking system and their thickness provides good protection.



The main greasing points are conveniently grouped on both sides of the frame, so the operator doesn't waste time lubricating.



The air filter, oil check and refuelling points are grouped on the right side under the wide shielding. The big open surface and 90-degree opening provide plenty of room for the technician to work on the engine.



## FLEET FORCE

### LOWER MAINTENANCE AND OPERATING COSTS

You can access the maintenance information of every unit in your fleet from your desk and receive alerts when a machine is due for service. The maintenance plans can be synchronised automatically with your dealer, so that they run smoothly and the good health of the entire fleet is maintained at all times.

### HEALTH CHECK AND BREAKDOWN PREVENTION

New Holland's telematics system will provide you with detailed performance information, such as engine load, fuel consumption and Can-Bus based reports, so that you will be able to detect immediately if any of your units is not operating as it should. You and your dealer will also be able to monitor up to 12 key health parameters for each unit, such as engine, coolant and hydraulic oil temperatures, and other Can-Bus based data. This will enable you to detect any anomalies before they become a problem and prevent equipment failures.

### EFFECTIVE FLEET MANAGEMENT

New Holland's telematics system puts you in direct contact with each machine in your fleet, collects the performance and maintenance information from the units and their location data from GPS satellites and transmits it all through the mobile networks to the New Holland Telematics Web Portal: you can manage your fleet efficiently without leaving your desk.

### MAXIMISE YOUR FLEET'S PRODUCTIVITY

You can map the location of every unit and monitor when it is working, idle or travelling between jobsites. By identifying under- or over-used machines, you will be able to optimise the utilisation of the equipment through effective job assignment and preventing machines being left idling when not working.

### SECURITY AND CONTROL

You can also geo-fence your machines so that an e-mail alert is sent if one is taken out of the jobsite. You can also prevent the unauthorised use of the units setting up a working curfew and motion detection service to alert you if a machine is moved out of hours. By improving your fleet's security, you will also benefit from lower insurance premiums.



#### 1 GPS POSITIONING

Your machine receives its GPS positioning from the satellite.



#### 2 INFORMATION GATHERING

Your machine collects its working condition, engine and Can-Bus information, and sends it to the New Holland Fleetforce Web Portal through the mobile networks.



#### 3 INFORMATION STORAGE AND PROCESSING

The New Holland Fleetforce Web Portal stores all your machine's information throughout its life cycle and makes it accessible to you in a user-friendly format.



#### 4 MANAGING YOUR FLEET

You can access your machine's reports on your computer, through the New Holland Fleetforce Web Portal, and manage your fleet without leaving your desk.

## SPECIFICATIONS



### ENGINE

Model..... FPT, F4HFE613Z\*A005 Tier 4 Interim  
 Cylinders..... 6  
 Displacement..... 6.7 l  
 Fuel injection..... Direct  
 Fuel filter..... Spin-on w/ in-line strainer  
 Air intake..... Cross-flow  
 Cooling..... Liquid  
 Engine speeds..... RPM  
 High idle - no load..... 2200 +/- 50  
 Rated - full load..... 2000  
 Low idle..... 800 +/- 25  
 Horsepower SAE J1349:  
 Net..... 123 hp - 92 kW @ 2000 rpm  
 Gross..... 134 hp - 100 kW @ 1800 rpm

#### Engine lubrication

Pump..... Deep sump plate cooler w/ pressurized under-piston nozzles

#### Pump operating angle ratings:

Side-to-side..... 35°  
 Fore and aft..... 45°  
 Radiator:  
 Core size area..... 0.26 m<sup>2</sup>  
 Rows of tubes..... 25

#### Fan

Diameter..... 662 mm  
 Ratio..... 1.1:1



### TRANSMISSION

#### Dual path hydrostatic

Pump..... Variable axial piston  
 Motor..... Variable bent axis piston  
 Max. drawbar pull\*..... 213.5 kN  
 Transmission..... Single lever control electronic straight tracking  
 Oil filter..... 2 micron, spin-on, replaceable

#### Travel speeds\*

Forward..... 0 – 9.3 km/h  
 Reverse..... 0 – 9.3 km/h  
 Parking brakes..... Heavy-duty, spring-applied, hydraulic pressure release

Steering brakes..... Hydrostatic  
 Final drive..... 2 helical gear reduction to planetary output  
 Ratio..... 61.4:1

#### Transmission cooling

Type..... Oil to air  
 Core size..... 0.41 m<sup>2</sup>



### ELECTRICAL SYSTEM

Alternator..... 120 amps  
 Batteries (2)..... 12-volt, low-maintenance  
 950 cold-cranking amps @ -18°C



### CAB AND CONTROLS

ROPS/FOPS cab; Pneumatically suspended seat; Seat belt;  
 Adjustable armrests; Foot rests; Tool storage area; Headliner;

Floor mat; Mirror; Noise level 78dba

#### Warning lights:

Air filter; Alternator; Diagnostic fault indicator; Engine coolant temperature; Engine oil pressure; Hydraulic filter; Low fuel level; Park brake engaged; Service soon indicator; Transmission filter; Transmission charge pressure.

#### Gauges:

Ad Blue Level; Battery voltage; Digital hourmeter/tachometer diagnostic/service reminder; Fuel level; Transmission oil temperature; Transmission speed indicator; Water temperature.

#### Audible warnings:

Engine coolant temperature; Engine oil pressure; Low fuel level; Transmission charge pressure; Transmission/hydraulic temperature; Rear wiper for cab; Internal mirror; Radio.



### HYDRAULIC SYSTEM

Pump flow @ 2200 RPM..... 140 l/min  
 Max pressure..... 206 bar

**Lift cylinder™**..... nr. 2  
 Bore diameter..... 108 mm  
 Rod diameter..... 50.8 mm  
 Stroke..... 488 mm

**Angle cylinder**..... nr. 2  
 Bore diameter..... 114.3 mm  
 Rod diameter..... 63.5 mm  
 Stroke..... 465.7 mm

**Tilt cylinder**..... nr. 1  
 Bore diameter..... 127 mm  
 Rod diameter..... 63.5 mm  
 Stroke..... 148.3 mm



### CAPACITIES

Fuel tank..... 322 l  
 Ad Blue tank..... 52 l  
 Engine oil w/ filter..... 16.4 l  
 Engine oil w/o filter..... 15.6 l  
 Engine cooling system..... 32.5 l  
 Hydraulic reservoir..... 98.4 l  
 Final drive (per side)..... 14.2 l  
 Track rollers (ea)..... 0.275 l  
 Front idlers (ea)..... 0.225 l  
 Carrier rollers – each..... 0.334 l



### TRACK

Track adjustment..... Hydraulic  
 Frame..... Oscillating equalizer beam suspension and pivot shaft  
**Track link pitch**..... 175 mm  
 Track shoe height..... 52.5 mm  
 Pin diameter..... 36.58 mm

#### Bushing diameter

SALT track..... 62 mm  
 ALT track..... 79 mm

**Track shoes per side**..... 43  
 Track rollers per side..... 7  
 Carrier rollers per side..... 2  
 Track roller rail diameter..... 190 mm

#### Track on ground

Shoe area  
 508 mm..... 26323 cm<sup>2</sup>  
 559 mm..... 28965 cm<sup>2</sup>  
 660 mm..... 34199 cm<sup>2</sup>  
 762 mm..... 39484 cm<sup>2</sup>



### BLADE

Variable blade pitch..... 55° +/- 5°  
 Lift speed – per second..... 503 mm  
 Cutting edge..... Reversible, replaceable  
 Width..... 203.2 mm  
 Thickness..... 19.1 mm



### RIPPER

Max. penetration..... 478 mm  
 Width..... 1711 mm  
 Cut..... 1635 mm  
 Max. ground clearance..... 424 mm  
 Max. number of shanks..... 3  
 Tooth spacing  
 w/3 teeth..... 785 mm  
 Hydraulic cylinder..... Double-acting  
 Diameter..... 102 mm  
 Stroke..... 254 mm  
 Rod..... 51 mm

## OPERATING WEIGHT

Unit equipped CAB, full fuel tank, 170 lb (77 kg) operator, side shield, track guides, backup alarm, horn, lights and rear retrieval hitch.

	Weight (kg)
Long Track	13.809
Wide Track	14.807
Low Ground pressure	14.988

ADD-ON WEIGHTS	Weight (kg)
Drawbar	66
Ripper (3 shank)	1027
Front counterweight	432

ALT CHAIN - PER TRACK	Weight (kg)
20" (508 mm)	1002
22" (559 mm)	1057
26" (660 mm)	1160
30" (762 mm)	1265
Center rockguard	134
Sweeps	63

## TRACK AND SHOE OPTIONS

LT (LONG TRACKS)	
508 mm	closed grousers and SALT
508 mm	open grousers and ALT
559 mm	closed grousers and SALT
559 mm	open grousers and ALT

WT (WIDETRACKS)	
559 mm	closed grousers and SALT
559 mm	open grousers and ALT
660 mm	closed grousers and SALT
660 mm	open grousers and ALT

LGP (LOW GROUND PRESSURE)	
762 mm	closed grousers and SALT
762 mm	open grousers and ALT

\*Measured using standard track chain. Increase travel speeds by 4% and reduce drawbar pull by 4% w/ the optional ALT track chain

# D125C

## DIMENSIONS

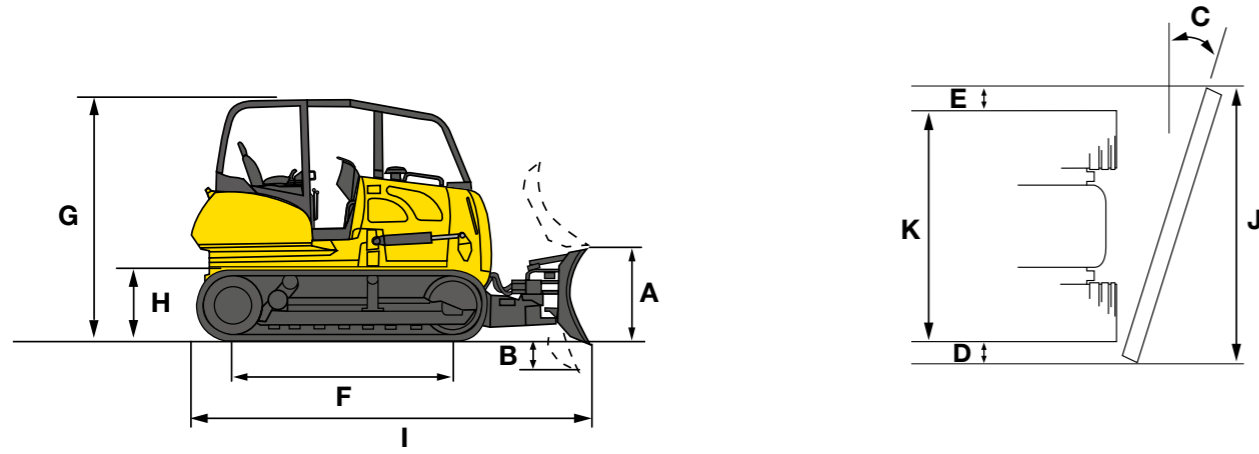

Line drawings are for illustrative purpose only and may not be exact representation of unit.

MACHINE MODEL		LT (LONG TRACK)	WT (WIDE TRACK)	LGP (LOW GROUND PRESSURE)
<b>BLADES</b>				
Blade width	mm	3048	3353	3353
SAE blade capacity	m <sup>3</sup>	2.87	3.18	3.18
<b>A</b> Blade height	mm	1120	1120	1120
Blade lift above ground	mm	956	956	956
<b>B</b> Blade depth below ground	mm	539	590	590
<b>C</b> Blade angle both directions	°	25	25	25
Blade tilt, each end (up to 8.3°)	mm	430	450	450
<b>D</b> Cast reach	mm	380	370	319
<b>E</b> Cut reach	mm	24	12	63
<b>TRACKS</b>				
Track gauge	mm	1830	2030	2030
Max shoe width	kg	559	660	762
<b>F</b> Track on ground	mm	2590	2590	2590
Area of track on ground	m <sup>2</sup>	2.90	3.42	3.95
Ground pressure	kg/cm <sup>2</sup>	0.44 *	0.37 **	0.32 ***
<b>DIMENSIONS</b>				
<b>G</b> Height to top of cab	mm	2948	2948	2948
<b>H</b> Ground clearance	mm	330	330	330
<b>I</b> Length				
- Blade straight with drawbar	mm	5080	5080	5080
- Blade straight with ripper	mm	6150	6150	6150
Width				
- Blade straight	mm	3048	3353	3353
<b>J</b> Blade angled	mm	2773	3050	3050
<b>K</b> Over track	mm	2396	2692	2794

\*with 559 mm shoes  
\*\* with 660 mm shoes  
\*\*\*with 762 mm shoes

NOTE: Ground clearance and overall height dimensions are with the grousers fully penetrated. Add 52.5 mm if unit is on solid surface.





# D150C

## SPECIFICATIONS



### ENGINE

Model..... FPT, F4HFE613Z\*A008 Tier 4 Interim  
Cylinders..... 6  
Displacement..... 6.7 l  
Fuel injection..... Direct common rail  
Fuel filter..... Spin-on w/ in-line strainer  
Air intake..... Cross-flow  
Cooling..... Liquid  
Engine speeds..... RPM  
High idle - no load..... 2200 +/- 50  
Rated - full load..... 2000  
Low idle..... 800 +/- 25  
Horsepower SAE J1349:

Net..... 149 hp - 111 kW @ 2000 rpm  
Gross..... 162 hp - 121 kW @ 1800 rpm

#### Engine lubrication

Pump..... Deep sump plate cooler w/ pressurized under-piston nozzles

#### Pump operating angle ratings:

Side-to-side..... 35°  
Fore and aft..... 45°

#### Radiator:

Core size area..... 0.61 m<sup>2</sup>  
Rows of tubes..... 4

#### Fan

Diameter..... 700 mm  
Ratio..... Hydraulically driven



### TRANSMISSION

#### Dual path hydrostatic

Pump..... Variable axial piston  
Motor..... Variable bent axis piston  
Max. drawbar pull\*..... 311 kN  
Transmission..... Single lever control electronic straight tracking  
Oil filter..... 2 micron, spin-on, replaceable

#### Travel speeds\*

Forward..... 0 – 9.3 km/h  
Reverse..... 0 – 9.3 km/h  
Parking brakes..... Heavy-duty, spring-applied, hydraulic pressure release

Steering brakes..... Hydrostatic  
Final drive..... 2 helical gear reduction to planetary output  
Ratio..... 61.4:1

#### Transmission cooling

Type..... Oil to air  
Core size..... 0.31 m<sup>2</sup>



### ELECTRICAL SYSTEM

Alternator..... 120 amps  
Batteries (2)..... 12-volt, low-maintenance  
950 cold-cranking amps @ -18°C



### CAB AND CONTROLS

ROPS/FOPS cab; Pneumatically suspended seat; w/ back adjustment;  
Seat belt; Adjustable armrests; Foot rests; Tool storage area;

Headliner; Floor mat; Tilting seat platform; Noise Level 75 dbA.

#### Warning lights:

Air filter; Alternator; Diagnostic fault indicator; Engine coolant temperature; Engine oil pressure; Hydraulic filter; Low fuel level; Park brake engaged; Service soon indicator; Transmission filter; Transmission charge pressure.

#### Gauges:

Battery voltage; Digital hourmeter/tachometer diagnostic/ service reminder; Fuel level; Transmission oil temperature; Transmission speed indicator; Water temperature.

#### Audible warnings:

Engine coolant temperature; Engine oil pressure; Low fuel level; Transmission charge pressure; Transmission/hydraulic temperature.



### HYDRAULIC SYSTEM

Pump flow @ 2200 RPM..... 160 l/min

Max pressure..... 248 bar

**Lift cylinder PAT**..... nr. 2

Bore diameter..... 114.3 mm

Rod diameter..... 63.5 mm

Stroke..... 428 mm

**Angle cylinder PAT**..... nr. 2

Bore diameter..... 114 mm

Rod diameter..... 63.5 mm

Stroke..... 502.7 mm

**Tilt cylinder PAT**..... nr. 1

Bore diameter..... 127 mm

Rod diameter..... 63.5 mm

Stroke..... 148.3 mm

**Lift cylinder Bull Dozer**.....

Bore diameter..... 82.6 mm

Rod diameter..... 50.8 mm

Stroke..... 1000 mm

**Tilt cylinder Bull Dozer**.....

Bore diameter..... 114.3 mm

Rod diameter..... 36.5 mm

Stroke..... 126 mm



### CAPACITIES

Fuel tank..... 322 l

Ad Blue tank..... 52 l

Engine oil w/ filter..... 16.4 l

Engine oil w/o filter..... 15.6 l

Engine cooling system..... 30.2 l

Hydraulic reservoir..... 160 l

Final drive - per side..... 14.2 l

Track rollers - each..... 0.275 l

Front idlers - each..... 0.225 l

Carrier rollers - each..... 0.334 l



### TRACK

Track adjustment..... Hydraulic  
Frame..... Oscillating equalizer beam suspension and pivot shaft

#### Track link pitch

SALT track..... 190 mm

ALT track..... 190 mm

Track shoe height..... 56 mm

Pin diameter..... 38 mm

#### Bushing diameter

SALT track..... 65 mm

ALT track..... 86 mm

#### Track shoes per side

SALT track..... 45

ALT track..... 45

Track rollers per side..... 8

Carrier rollers per side..... 2

Track roller rail diameter..... 171.5 mm

#### Track on ground

Shoe area

559 mm..... 34093 cm<sup>2</sup>

610 mm..... 37204 cm<sup>2</sup>

711 mm..... 49524 cm<sup>2</sup>

819 mm..... 37204 cm<sup>2</sup>

864 mm..... 52695 cm<sup>2</sup>



### BLADE

Variable blade pitch - adjustable..... 55° +/- 5°

Lift speed - per second..... 483 mm

Cutting edge..... Reversible, replaceable

Width..... 200 mm

Thickness..... 20 mm



### RIPPER

Max. penetration..... 570 mm

Width..... 1953 mm

Cut width..... 1889 mm

Max. ground clearance..... 592 mm

Max. number of shanks..... 3

Tooth spacing

w/3 teeth..... 944 mm

Hydraulic cylinder..... Double-acting

Diameter..... 155 mm

Stroke..... 596 mm

Rod..... 69 mm

## OPERATING WEIGHT

Operating weight includes cab, full fuel and hydraulic tanks, 170 lb (77 kg) operator, SALT chain, front pull hook, rear retrieval hitch, track guides, back up alarm, horn, lights, track shoe, C-frame and blade width as noted.

	Weight (kg)
Extra Long Track	17899 kg PAT 18806 kg Semi-U
Wide Track	18307 kg PAT
Low Ground Pressure	18716 kg PAT

ADD-ON WEIGHTS	Weight (kg)
Drawbar	66
Ripper (3 shank)	1355
Front counterweight	2500

ALT CHAIN - PER TRACK	Weight (kg)
22" (559 mm)	1510
24" (610 mm)	1580
28" (711 mm)	1711
32" (819 mm)	1801
34" (864 mm)	1913
Center rockguard	259
Sweeps	63

## TRACK AND SHOE OPTIONS

XLT (LONG TRACKS)	
559 mm	closed grousers and SALT
559 mm	open grousers and ALT
610 mm	closed grousers and SALT
610 mm	open grousers and ALT

WT (WIDE TRACKS)	
711 mm	closed grousers and SALT
711 mm	open grousers and ALT

LGP (LOW GROUND PRESSURE)	
819 mm	closed grousers and SALT
819 mm	open grousers and ALT
864 mm	closed grousers and SALT
864 mm	open grousers and ALT

\*Measured using standard track chain. Increase travel speeds by 4% and reduce drawbar pull by 4% w/ the optional ALT track chain

# D150C

## DIMENSIONS

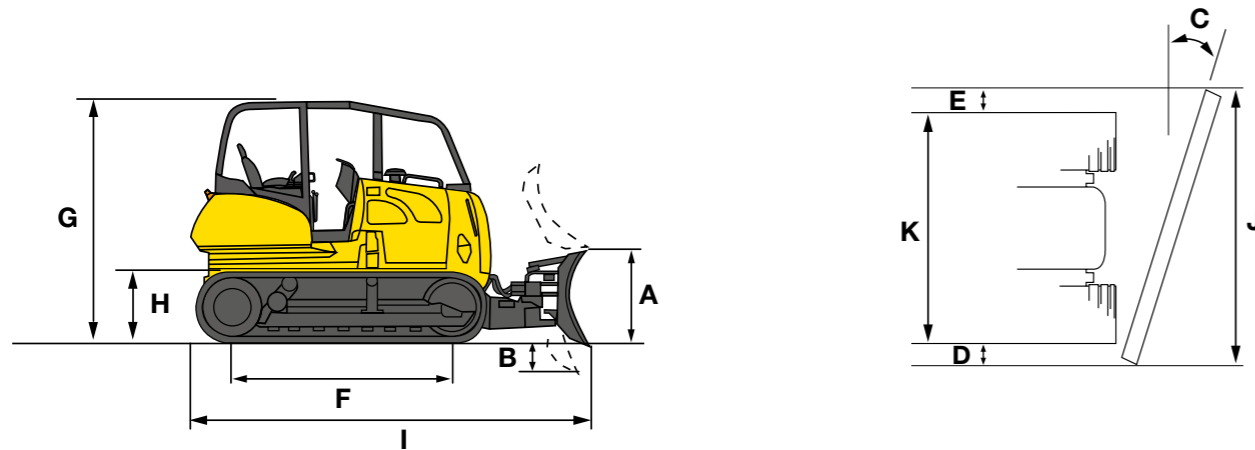

Line drawings are for illustrative purpose only and may not be exact representation of unit.

BLADE DIMENSIONS		BULL DOZER SEMI-U	STRAIGHT PAT	STRAIGHT PAT	FOLDABLE PAT
Blade Capacity SAE J1265	m <sup>3</sup>	5.58	3.15	3.15	3.15
Undercarriage available		XLT	XLT	WT-LGP	WT - LGP
<b>J</b> Blade width	mm	3426	3302	3974	3974
Blade width in transport position	mm	3426	3000	3608	2887
<b>A</b> Blade height	mm	1420	1180	1000	1000
Max. Tilt	mm	+/- 420	+/- 450	+/- 550	+/- 550
Max. Pitch	°	+/- 5	+/- 5	+/- 5	+/- 5
<b>C</b> Max. Angle	°	-	+/- 28	+/- 28	+/- 28
<b>B</b> Digging depth.	mm	596	539	590	590
Max lift above ground	mm	1133	1130	1130	1130
<b>D</b> Cast reach	mm	468	457	558	584
<b>E</b> Cut reach	mm	468	53	154	80

MACHINE MODEL		XLT (EXTRA LONG TRACK)	WT (WIDETRACK)	LGP (LOW GROUND PRESSURE)
<b>TRACKS</b>				
Track gauge	mm	1930	2180	2180
Max shoe width	mm	610	711	864
<b>F</b> Track on ground	mm	3050	3050	3050
Area of track on ground	m <sup>2</sup>	3.72	4.30	5.26
Ground pressure	kg/cm <sup>2</sup>	0.42 *	0.38 **	0.31 ***
<b>DIMENSIONS</b>				
<b>G</b> Height to top of cab	mm	2948	2948	2948
<b>H</b> Ground clearance	mm	321	321	321
<b>I</b> Length				
- Blade straight with drawbar	mm	5678 PAT - 5928 Semi-U	5678	5678
- Blade straight with ripper	mm	6670 PAT - 6920 - Semi-U	6670	6670
Width				
- Blade straight	mm	3302 PAT - 3426 Semi-U	3974 PAT	3974 PAT
<b>J</b> Blade angled	mm	3000 PAT	3608 PAT 2887 PAT Foldable	3608 PAT 2887 PAT Foldable
<b>K</b> Over track	mm	2489 with 559 shoes	2895 with 711 shoes	3044 with 864 shoes

\* with 610 mm shoes and PAT blade  
 \*\* with 711 mm shoes and PAT blade  
 \*\*\* with 864 mm shoes and PAT blade

NOTE: Ground clearance and overall height dimensions are with the grousers fully penetrated. Add 52.5 mm if unit is on solid surface.



# D180C

## SPECIFICATIONS



### ENGINE

Model..... FPT, F4HFE613W\*A004 Tier 4 Interim  
Cylinders..... 6  
Displacement..... 6.7 l  
Fuel injection..... Direct common rail  
Fuel filter..... Spin-on w/ in-line strainer  
Air intake..... Cross-flow  
Cooling..... Liquid  
Engine speeds..... RPM  
High idle - no load..... 2200 +/- 50  
Rated - full load..... 2000  
Low idle..... 800 +/- 25  
Horsepower SAE J1349:

Net..... 210 hp - 156 kW @ 2000 rpm  
Gross..... 226 hp - 166 kW @ 1800 rpm

#### Engine lubrication

Pump..... Deep sump plate cooler w/ pressurized under-piston nozzles

#### Pump operating angle ratings:

Side-to-side..... 35°  
Fore and aft..... 45°

#### Radiator:

Core size area..... 0.61 m<sup>2</sup>  
Rows of tubes..... 4

#### Fan

Diameter..... 700 mm  
Ratio..... hydraulically driven



### TRANSMISSION

#### Dual path hydrostatic

Pump..... Variable axial piston  
Motor..... Variable bent axis piston  
Max. drawbar pull\*..... 372 kN

Transmission..... Single lever control electronic straight tracking  
Oil filter..... 2 micron, spin-on, replaceable

#### Travel speeds\*

Forward..... 0 – 9.3 km/h  
Reverse..... 0 – 9.3 km/h

Parking brakes..... Heavy-duty, spring-applied, hydraulic pressure release

Steering brakes..... Hydrostatic  
Final drive..... 2 helical gear reduction to planetary output

Ratio..... 48.75 : 1

#### Transmission cooling

Type..... Oil to air  
Core size..... 0.31 m<sup>2</sup>



### ELECTRICAL SYSTEM

Alternator..... 120 amps  
Batteries (2)..... 12-volt, low-maintenance  
950 cold-cranking amps @ -18°C



### CAB AND CONTROLS

ROPS/FOPS cab; Pneumatically suspended seat; w/ back adjustment; Seat belt; Adjustable armrests; Foot rests; Tool storage

area; Headliner; Floor mat; Tilting seat platform; Noise level 78dbA.

#### Warning lights:

Air filter; Alternator; Diagnostic fault indicator; Engine coolant temperature; Engine oil pressure; Hydraulic filter; Low fuel level; Park brake engaged; Service soon indicator; Transmission filter; Transmission charge pressure.

#### Gauges:

Battery voltage; Digital hourmeter/tachometer diagnostic/ service reminder; Fuel level; Transmission oil temperature; Transmission speed indicator; Water temperature.

#### Audible warnings:

Engine coolant temperature; Engine oil pressure; Low fuel level; Transmission charge pressure; Transmission/hydraulic temperature.



### HYDRAULIC SYSTEM

Pump flow @ 2200 RPM..... 160 l/min  
Max pressure..... 248 bar

**Lift cylinder PAT**..... nr: 2  
Bore diameter..... 114.3 mm  
Rod diameter..... 63.5 mm  
Stroke..... 428 mm

**Angle cylinder PAT**..... nr: 2  
Bore diameter..... 114 mm  
Rod diameter..... 63.5 mm  
Stroke..... 502.7 mm

**Tilt cylinder PAT**..... nr: 1  
Bore diameter..... 127 mm  
Rod diameter..... 63.5 mm  
Stroke..... 148.3 mm

**Lift cylinder Bull Dozer**.....  
Bore diameter..... 82.6 mm  
Rod diameter..... 50.8 mm  
Stroke..... 1000 mm

**Tilt cylinder Bull Dozer**.....  
Bore diameter..... 114.3 mm  
Rod diameter..... 36.5 mm  
Stroke..... 126 mm

**Lift cylinder Bull Dozer**.....  
Bore diameter..... 82.6 mm  
Rod diameter..... 50.8 mm  
Stroke..... 1000 mm

**Tilt cylinder Bull Dozer**.....  
Bore diameter..... 114.3 mm  
Rod diameter..... 36.5 mm  
Stroke..... 126 mm

**Lift cylinder Bull Dozer**.....  
Bore diameter..... 82.6 mm  
Rod diameter..... 50.8 mm  
Stroke..... 1000 mm

**Tilt cylinder Bull Dozer**.....  
Bore diameter..... 114.3 mm  
Rod diameter..... 36.5 mm  
Stroke..... 126 mm

**Lift cylinder Bull Dozer**.....  
Bore diameter..... 82.6 mm  
Rod diameter..... 50.8 mm  
Stroke..... 1000 mm

**Tilt cylinder Bull Dozer**.....  
Bore diameter..... 114.3 mm  
Rod diameter..... 36.5 mm  
Stroke..... 126 mm

**Lift cylinder Bull Dozer**.....  
Bore diameter..... 82.6 mm  
Rod diameter..... 50.8 mm  
Stroke..... 1000 mm

**Tilt cylinder Bull Dozer**.....  
Bore diameter..... 114.3 mm  
Rod diameter..... 36.5 mm  
Stroke..... 126 mm

**Lift cylinder Bull Dozer**.....  
Bore diameter..... 82.6 mm  
Rod diameter..... 50.8 mm  
Stroke..... 1000 mm

**Tilt cylinder Bull Dozer**.....  
Bore diameter..... 114.3 mm  
Rod diameter..... 36.5 mm  
Stroke..... 126 mm

**Lift cylinder Bull Dozer**.....  
Bore diameter..... 82.6 mm  
Rod diameter..... 50.8 mm  
Stroke..... 1000 mm

**Tilt cylinder Bull Dozer**.....  
Bore diameter..... 114.3 mm  
Rod diameter..... 36.5 mm  
Stroke..... 126 mm

**Lift cylinder Bull Dozer**.....  
Bore diameter..... 82.6 mm  
Rod diameter..... 50.8 mm  
Stroke..... 1000 mm

**Tilt cylinder Bull Dozer**.....  
Bore diameter..... 114.3 mm  
Rod diameter..... 36.5 mm  
Stroke..... 126 mm

**Lift cylinder Bull Dozer**.....  
Bore diameter..... 82.6 mm  
Rod diameter..... 50.8 mm  
Stroke..... 1000 mm

**Tilt cylinder Bull Dozer**.....  
Bore diameter..... 114.3 mm  
Rod diameter..... 36.5 mm  
Stroke..... 126 mm

**Lift cylinder Bull Dozer**.....  
Bore diameter..... 82.6 mm  
Rod diameter..... 50.8 mm  
Stroke..... 1000 mm

Track shoe height..... 71.5 mm  
Pin diameter..... 44 mm

#### Bushing diameter

SALT track..... 72 mm  
ALT track..... 93 mm

#### Track shoes per side

SALT/ALT track..... 40 LT  
45 XLT /WT/LGP

#### Track rollers per side

LT..... 7  
XLT / WT-LGP..... 8

Carrier rollers per side..... 2  
Track roller rail diameter..... 187.5 mm

#### Track on ground

Shoe area  
610 mm..... 32269 cm<sup>2</sup> LT  
39979 cm<sup>2</sup> XLT

711 mm..... 45599 cm<sup>2</sup> WT  
762 mm..... 49941 cm<sup>2</sup> WT

914 mm..... 59904 cm<sup>2</sup> LGP



### BLADE

Variable blade pitch - adjustable..... 55° +/- 5°  
Lift speed - per second..... 483 mm

Cutting edge..... Reversible, replaceable  
Width..... 200 mm

Thickness..... 20 mm



### RIPPER

Max. penetration..... 570 mm  
Width..... 1953 mm

Cut width..... 1889 mm  
Max. ground clearance..... 592 mm

Max. number of shanks..... 3  
Tooth spacing

w/3 teeth..... 944 mm  
Hydraulic cylinder..... Double-acting

Diameter..... 155 mm  
Stroke..... 596 mm

Rod..... 69 mm

## OPERATING WEIGHT

Operating weight includes cab, full fuel and hydraulic tanks, 170 lb (77 kg) operator, SALT chain, front pull hook, rear retrieval hitch, track guides, back up alarm, horn, lights, track shoe, C-frame and blade width as noted.

	Weight (kg)
Long Track	20213 kg PAT 20206 kg Straight 20485 kg Semi-U
Extra Long Tracks	20599 kg PAT 20592 kg Straight 20871 kg Semi-U
Wide Tracks	21269 kg PAT 21971 kg PAT Foldable 21431 kg Straight
Low Ground Pressure	22115 kg PAT 22790 kg PAT Foldable 22123 kg Straight

ADD-ON WEIGHTS	Weight (kg)
Drawbar	66
Ripper (3 shank)	1355
Winch	2500

ALT CHAIN - PER TRACK	Weight (kg)
24" (610 mm)	1591
28" (711 mm)	1964
30" (762 mm)	2009
36" (914 mm)	2314
Center rockguard	
LT	221
XLT/WT/LGP	306
Sweeps	63

## TRACK AND SHOE OPTIONS

LT (LONG TRACKS)	
610 mm	closed grousers and SALT
610 mm	open grousers and ALT

XLT (LONG TRACKS)	
610 mm	closed grousers and SALT
610 mm	open grousers and ALT

WT (WIDE TRACKS)	
711 mm	closed grousers and SALT
711 mm	open grousers and ALT
762 mm	closed grousers and SALT
762 mm	open grousers and ALT

LGP (LOW GROUND PRESSURE)	
914 mm	closed grousers and SALT
914 mm	open grousers and ALT

\*Measured using standard track chain. Increase travel speeds by 4% and reduce drawbar pull by 4% w/ the optional ALT track chain

# D180C

## DIMENSIONS

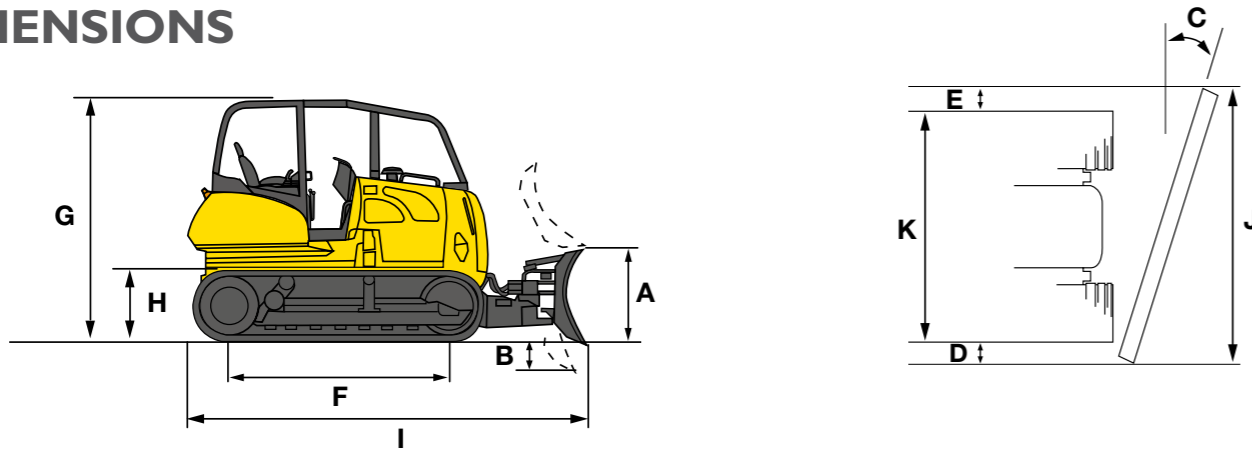

Line drawings are for illustrative purpose only and may not be exact representation of unit.

BLADE DIMENSIONS		BULL DOZER STRAIGHT	BULL DOZER STRAIGHT	BULL DOZER SEMI-U	STRAIGHT PAT	STRAIGHT PAT	FOLDABLE PAT
Blade Capacity SAE J1265	m <sup>3</sup>	3.54	3.70	5.58	4.82	5.43	5.43
Undercarriage available		LT -XLT	WT - LGP	LT-XLT	LT-XLT	WT-LGP	WT - LGP
<b>J</b> Blade width	mm	3334	3901	3426	3606	4064	4064
Blade width in transport position	mm	3334	3901	3426	3287	3690	3023
<b>A</b> Blade height	mm	1128	1110	1420	1310	1318	1318
Max. Tilt	mm	+/-422	+/-450	+/- 411	+/- 450	+/- 550	+/- 550
Max. Pitch	°	+/- 5	+/- 5	+/- 5	+/- 5	+/- 5	+/- 5
<b>C</b> Max. Angle	°	-	-	-	+/- 28	+/- 28	+/- 28
<b>B</b> Digging depth.	mm	545	539	583	590	590	590
Max lift above ground	mm	1169	1165	1244	1130	1130	1130
<b>D</b> Cast reach	mm	393	363	438	582	472	548
<b>E</b> Cut reach	mm	393	363	438	154	43	119

MACHINE MODEL		LT (LONG TRACK)	XLT (EXTRA LONG TRACK)	WT (WIDETRACK)	LGP (LOW GROUND PRESSURE)
<b>TRACKS</b>					
Track gauge	m	1940 mm	1940 mm	2260 mm	2260 mm
Max shoe width	mm	610 mm	711 mm	762 mm	914 mm
<b>F</b> Track on ground	m	2645 mm	3277 mm	3277 mm	3277 mm
Area of track on ground	m <sup>2</sup>	3.22 m <sup>2</sup>	4.65 m <sup>2</sup>	4.99 m <sup>2</sup>	5.99 m <sup>2</sup>
Ground pressure	kg/cm <sup>2</sup>	0.62 kg/cm <sup>2</sup> *	0.44 kg/cm <sup>2</sup> **	0.42 kg/cm <sup>2</sup> ***	0.36 kg/cm <sup>2</sup> ****
<b>DIMENSIONS</b>					
<b>G</b> Height to top of cab	mm	3103 mm	3103 mm	3103 mm	3103 mm
<b>H</b> Ground clearance	mm	325 mm	325 mm	325 mm	325 mm
<b>I</b> Length					
- Blade straight with drawbar	mm	5491 mm PAT 5387 mm Straight / Semi-U	5902 mm PAT 5387 mm Straight / Semi-U	5902 mm PAT 5894 mm Straight	5902 mm PAT 5894 mm Straight
- Blade straight with ripper	mm	6974 mm PAT 6869 mm Straight / Semi-U	7383 mm PAT 6869 mm Straight / Semi-U	7383 mm PAT 6982 mm Straight	7383 mm PAT 6982 mm Straight
Width					
- Blade straight	mm	3606 mm PAT 3334 mm Straight 3426 mm Semi-U	3606 mm PAT 3334 mm Straight 3426 mm Semi-U	4064 mm PAT / PAT Foldable 3901 mm Straight	4064 mm PAT / PAT Foldable 3901 mm Straight
<b>J</b> Blade angled	mm	3287 mm PAT	3287 mm PAT	3690 mm PAT 3023 mm PAT Foldable	3690 mm PAT 3023 mm PAT Foldable
<b>K</b> Over track	mm	2550 mm with 610 mm shoes	2550 mm with 610 mm shoes	3022 mm with 762 mm shoes	3174 mm with 914 mm shoes

\* with 610 mm shoes and PAT blade    \*\* with 711 mm shoes and PAT blade    \*\*\* with 762 mm shoes and PAT blade    \*\*\*\* with 914 mm shoes and PAT blade

NOTE: Ground clearance and overall height dimensions are with the grousers fully penetrated. Add 52.5 mm if unit is on solid surface.

## STANDARD EQUIPMENT

- FPT FPT F4HFE613
- Tier 4 Interim Certified
- Integral engine oil cooling
- Fuel filter
- Dual element radial seal air cleaner
- 120 amp alternator
- 950 CCA 12-volt batteries
- Engine side panels
- Dual path infinitely variable, single-lever
- Controlled hydrostatic drive, with electronic straight tracking and counter-rotation
- Forward/reverse ratio control
- 3 pre-selectable steering sensitivities
- 3 reversing sensitivities
- 3 blades sensitivities
- Blade Shaking Mode
- Fine grading mode
- Triple reduction final drive: helical gear/planetary
- Decelerator with hydrostatic drive retardation
- Automatic spring applied parking brake
- Hydraulic track adjusters
- Sealed and Lubricated Tracks
- Permanently lubricated track and carrier rollers and idlers
- Track adjuster guard
- Track guides - front and rear
- 50° - 60° variable pitch with integral adjustment tool
- Single lever electro-hydraulic control for blade lift, angle, or tilt
- "Equistatic" device for bull dozer version
- Cab: with heater, A/C, defroster, windshield wiper and lights
- Seat belt - 76 mm
- Rear wiper for cab
- Internal mirror
- Radio
- Backup alarm
- Horn
- Lights: 2 front, 1 rear
- Master disconnect switch
- Mirror
- Rear transmission guard

## OPTIONS

- Ripper - 5 position with 3 shanks
- Rear tow hook
- Drawbar
- Cab rear screen
- Radiator brush screen
- 4 spool hydraulic valve for field-installed ripper
- 3 spool hydraulic valve without plugs for field-installed ripper
- 3 spool hydraulic valve with plugs
- CAB canopy brush guard
- Center rockguard
- Sweeps
- PAT 3.04 m (D125C)
- PAT 3.35 m (D125C)
- PAT 3.30 m (D150C XLT)
- PAT 3.97 m (D150C WT-LGP)
- Foldable PAT 3.97 m (D150C WT-LGP)
- PAT 3.60 m (D180C LT-XLT)
- PAT 4.06 m (D180C WT-LGP)
- Foldable PAT 4.06 m (D180C WT-LGP)
- Straight 3.33 m (D180C LT-XLT)
- Straight 3.90 m (D180C WT-LGP)
- Semi-U 3.42 m (D150C-D180C)
- Environmental drain
- Advanced Life Track
- Grid heater
- Additional work lights
- Front pull hook
- Front counterweight (D125C only)
- Blade guidance ready - Trimble
- Blade guidance ready - Leica
- Blade guidance ready - Topcon
- Rearview mirror
- Fleet Force Telematics tool

# PARTS AND SERVICE

The New Holland dealer network is, in itself, the best guarantee of continued productivity for the machines it delivers to its customers. New Holland service technicians are fully equipped to resolve all maintenance and repair issues, with each and every service point providing the high standards they are obliged to observe under New Holland's stringent quality guidelines. The New Holland global parts network ensures fast, reliable, replacement parts for less downtime, increased productivity and, of course, profitable operation for its customers.



## AT YOUR OWN DEALERSHIP

The information contained in this brochure is intended to be of general nature only. The NEW HOLLAND KOBELCO CONSTRUCTION MACHINERY S.p.A. company may at any time and from time to time, for technical or other necessary reasons, modify any of the details or specifications of the product described in this brochure. Illustrations do not necessarily show products in standard conditions. The dimensions, weights and capacities shown herein, as well as any conversion data used, are approximate only and are subject to variations within normal manufacturing techniques.

Published by NEW HOLLAND KOBELCO CONSTRUCTION MACHINERY S.p.A.  
Printed in Italy - MediaCross Firenze - Cod 30687GB - Printed 03/13

Printed on recycled paper  
CoC-FSC 000010 CQ Mixed sources



ELEMENTAL  
CHLORINE  
FREE  
GUARANTEED



[www.newholland.com](http://www.newholland.com)

