

CASE
CONSTRUCTION

850M
CRAWLER DOZER



850M Crawler Dozer

PUT MORE POWER TO THE GROUND.

The CASE 850M – engineered from top to bottom with mass and muscle in mind, led by its best-in-class drawbar pull. An uncompromising Tier 4 Interim engine coupled with a relentless hydrostatic transmission creates one of the most powerful dozers in the industry.

And on top of that sits a new cab designed to keep operators comfortable and in control like never before. It has powerful performance and rugged versatility to meet any application from fine grading to heavy dozing.



850M Highlights

- 1 Best-in-class drawbar pull** (8% greater than the competitor) provides constant power to keep pushing under extreme loads.
- 2 Advanced SCR engine technology** provides **10% fuel savings** over previous generations and greater uptime over competitive solutions.
- 3 New cab-forward design, floor-to-ceiling glass doors and sloped hood provide maximum visibility to the blade and ground.**
- 4 Track covers have been angled to 49 degrees for improved self-cleaning** in deep mud applications.
- 5 Positive-pressure cab** with advanced sealing and an isolated design keep out dust and noise to provide one of the industry's quietest operating environments.
- 6 Robust, box-style C-frame** is engineered to withstand the industry's strongest drawbar pull.
- 7 New cooling system** enables M Series dozers to maintain optimal performance under the highest load at 122° F.
- 8 Three-bolt, removable floor panel** in the cab provides clean, quick access to hydraulic components.
- 9 All daily checkpoints** are accessible from ground level and don't require the use of hand tools.
- 10 Larger heavy-duty cylinders** with improved seals designed to withstand best-in-class drawbar pull and deliver outstanding blade force.
- 11 Adjustable steering and shuttle settings** (Smooth, Moderate or Aggressive) to help match ground conditions and operator preference.
- 12 Optional factory-installed radio** enhances operating environment.

An exclusive solution.

CASE M Series are the only dozers powered exclusively by fuel-efficient SCR technology – the Tier 4 Interim solution proven to maximize power, minimize fuel use and reduce maintenance costs.



Precise controls. Productive comfort.

The 850M puts finesse at your fingertips to control the force up front. An upgraded dashboard and new control setup ensures blade control or machine movement can be performed with minimal effort. And because the best operator is a comfortable one, the M Series offers an all-new pressurized cab design that gives greater visibility, keeps out more dust, seals out more sound and provides a better balance for a smoother ride.



Serviceability is in our DNA.

Like all CASE equipment, the M Series is built to minimize maintenance time. Heavy-duty panels with pressure-closing latches are housed on a solid, one-piece frame that's designed to give quick access to key service points. Now daily maintenance can be done in a matter of minutes.



850M XLT

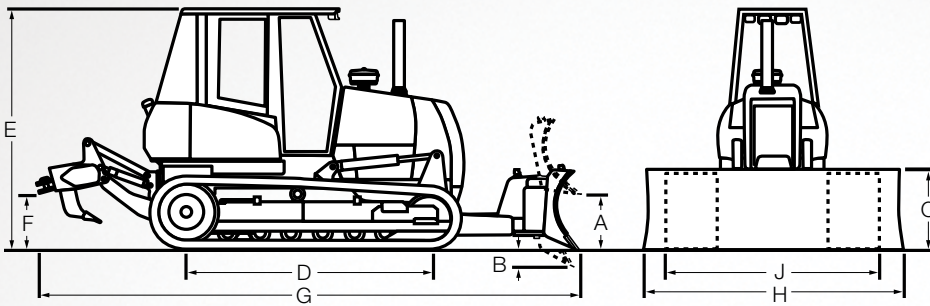

Line drawings are for illustrative purpose only and may not be exact representation of unit.

DIMENSIONS

	850M XLT
A. Blade Lift Above Ground	2 ft. 10 in. (874 mm)
B. Blade Depth Below Ground	1 ft. 7 in. (483 mm)
C. Blade Height	3 ft. 0 in. (915 mm)
D. Length Of Track On Ground	7 ft. 9 in. (2 362 mm)
E. Height To Top Of Cab	9 ft. 1 in. (2 770 mm)
F. Ground Clearance	1 ft. 2 in. (366 mm)
G. Length, Blade Straight With Ripper	17 ft. 2 in. (5 230 mm)
H. Width, Blade Straight	9 ft. 4 in. (2 844 mm)
J. Width, Over Track	6 ft. 8 in. (2 030 mm)

SPECIFICATIONS	850M XLT
Engine	FPT F4HFE413P
Engine Cylinders	4
Displacement – in. ³ (L)	275 (4.5)
Net hp (kW) @ 2000 RPM	112 (84)
Emissions Certification	Tier 4 Interim (SCR)
Operating Weight* – lb. (kg)	21,560 (9 779)
Blade Width*	9 ft. 4 in. (2 855)
Blade Capacity – yd ³ (m ³)	2.35 (1.80)
Maximum Drawbar Pull** – lb. (kN)	42,813 (190.4)

NOTE: *Various blade options available for each track configuration.

**Measured using standard track chain. Increase travel speeds by 4% and reduce drawbar pull by 4% with the optional CELT track chain.

Protected by

ProCare

The 850M comes standard with the industry's first all-in-one heavy machine support program that's as powerful as the equipment it protects – CASE ProCare. ProCare includes:

3K 3-year/3000-hr. Full-Machine Factory Warranty*

We've got your back – for up to three full years!

3-year/3000-hr. Planned Maintenance.

Don't spend another dime for scheduled care from factory-trained CASE technicians.

3-year SiteWatch™ Subscription.

Telematics isn't a luxury, it's a necessity – and we've made it accessible to all.



Scan to learn more
or visit CaseCE.com/procare.

NOTE: *See your dealer for the complete terms of CNH's Warranty and Limitation of Liability, which contains certain limits and exclusions.



©2014 CNH Industrial America LLC. All rights reserved. CASE is a trademark registered in the United States and many other countries, owned by or licensed to CNH Industrial N.V., its subsidiaries or affiliates. CNH Industrial Capital is a trademark in the United States and many other countries, owned by or licensed to CNH Industrial N.V., its subsidiaries or affiliates. Printed in U.S.A.

Form No. CCE201409850M
Replaces Form No. CCE201406850M



SAFETY™
NEVER HURTS

Always read the Operator's Manual before operating any equipment. Inspect equipment before using it, and be sure it is operating properly. Follow the product safety signs and use any safety features provided.

NOTE: All engines meet current EPA emissions regulations.

NOTE: All specifications are stated in accordance with SAE Standards or Recommended Practices, where applicable.



Contains 10%
post-consumer fiber

IMPORTANT: CASE Construction Equipment Inc. reserves the right to change these specifications without notice and without incurring any obligation relating to such change. Availability of some models and equipment builds vary according to the country in which the equipment is used. The illustrations and text may include optional equipment and accessories and may not include all standard equipment. Your CASE dealer/distributor will be able to give you details of the products and their specifications available in your area.



CASE construction equipment
is biodiesel-friendly.