

**T-SERIES BACKHOE LOADERS
580T | 580ST | 590ST | 695ST**

CASE
CONSTRUCTION



**THE CONSTRUCTION
KING**

www.casece.com
EXPERTS FOR THE REAL WORLD
SINCE 1842

MAIN REASONS TO CHOOSE THE T-SERIES



“IN-LINE” BACKHOE GEOMETRY

- Higher visibility thanks to the narrower frame, high stress resistance due to balanced effort distribution along the boom.



LOW PROFILE FOR EASY TRANSPORT

- The design with overlapping cylinders reduces the overall boom transport height to 3.5 m for 580ST and 3.7 m for 590ST and 695ST.



PROTECTED BACKHOE OPERATION

- The outer extendahoe is the perfect solution for tough working conditions: the sliding part never touches the soil preserving its efficiency.
- The gripper teeth provide an excellent material retention.



TIME SAVING

- The patented integrated hydraulic quick coupler allows changing over the backhoe attachments from the cab with a simple switch.
- The hydraulic side shift enables easy and quick backhoe replacement in all work conditions.



LOAD SENSING HYDRAULIC SYSTEM

- The variable displacement pump combined with Tier 3 engine reduces fuel consumption by up to 14%.



AUTO RIDE CONTROL

- Auto Ride Control offers 3 settings to match different working conditions.



COST SAVINGS

- The 4,5 litre FPT engine with high power and torque density dramatically reduces service time ensuring the lowest maintenance costs in the market.



SAFE AND EASY MAINTENANCE

- All the main check points are easily accessible from the ground.
- The front tilting engine hood and the perfect layout of the components enable fast routine maintenance operations.



COMFORTABLE AND SAFE CAB

- Excellent visibility for all operations with loader or backhoe.
- Fully openable front and rear windscreens for excellent cab ventilation.



4 WHEELS STEERING MODE

-The 695ST model shovel capacity along with 3 steering modes (Road, 4WS and Crab steer) provide exceptional on-site productivity. (Only for the model 695ST)



FAST LOADING CYCLE

- The return to dig mode guarantees precise automatic loader repositioning and easy to control loading operations.

ENGINE

A POWERFUL HEART



COST SAVINGS

FPT Multijet Engine

The 4.5 lt. FPT engine delivers a big performance in a small package with the lowest maintenance cost in the market:

- The air intake system with centrifugal pre-filter reduces the cleaning intervals
- High turbulence piston and air intake manifold
- High pressure multi-injection common rail for a perfect air-fuel mix and greater burning efficiency
- Mechanical Injection Pump for 580T ensures high power combined with an easy to maintain and serve injection system
- Viscous fan: no power is wasted with its low cooling demands

FPT: a leader in engine technologies.

- Fiat invented the «Common Rail» technology in the 80s
- Fiat Power Train produces over 600.000 industrial engines per year
- Our engines are used not only in earthmoving equipment but also in trucks, agricultural equipment, marine and military applications.



SAFE AND EASY MAINTENANCE

- Oil and filter check points are easily accessible on the left side of the bonnet. The front opening provides the operator with a full view of the engine components.
- The anti bumping frame surrounding the radiators prevents damage if the machine hits an obstacle at speeds up to 5 km/h, reducing unforeseen maintenance costs due to cracks in the radiators.



4 WHEELS STEERING MODE

CASE 695ST allows the operator to select 3 different steering modes: 2 wheel steering – Road steer for standard operations, 4 wheel steering for agile and fast operations and crab steer for restricted areas. This ensures great versatility and outstanding maneuverability. It's easy and safe to change the steering mode. The CASE 695ST is equipped with 4 equal size wheels to guarantee better weight distribution and more traction.



ROAD MODE



WHEEL STEER

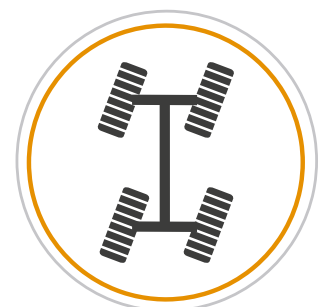

CRAB STEER

BACKHOE TAILORED MADE SOLUTIONS



PROTECTED BACKHOE OPERATION

The King's DNA

- The exclusive outer extendahoe is part of the CASE DNA: all the components in contact with the soil are protected against impact and material accumulation
- The gripper teeth provide perfect material retention especially when working on pipe placement
- The curved main boom provides greater digging ability and makes it easier to load a truck
- Pilot controls automatically deactivate when not in use for improved safety. They are immediately reactivated at the touch of a switch.



LOAD SENSING HYDRAULIC SYSTEM

Modulated power

The load sensing hydraulics provide just the right amount of oil for each task, even when the engine is running at low rpm. This results in fuel savings of up to 14% compared to traditional gear pumps. CASE is the only Backhoe loader manufacturer offering closed hydraulic centre whatever the choice of pump. Closed hydraulics enable simultaneous movements independent from work load and functions delivering constant power, better operator controllability and fast cycles.



“IN-LINE” BACKHOE GEOMETRY

No Stress power

Case has enriched the offering introducing a new backhoe design with “In-Line” cylinder geometry and inner extendahoe. The aligned cylinders ensure perfect visibility across the boom and reduce the structure bending distributing the stresses. This is the typical solution adopted on large excavators where productivity and reliability are a must. The new technology will flank the well known and more backhoe oriented CASE DNA boom with overlapping cylinders and outer extendahoe.

LOADER: STRAIGHT TO PERFORMANCE



AUTO RIDE CONTROL

Safe productivity

- Auto Ride Control reduces loader arm bounce during travel, maintaining maximum material retention on all surfaces, for higher travel speeds and reduced journey times. The system offers a choice of 3 settings to match customer preferences or different soil conditions.
- The front axle offers +/-11 degrees of oscillation, to maintain traction on the toughest terrain, improve bucket retention and maintain high productivity.
- Different tyre designs (from industrial to agricultural) and technologies (radial or bias) are available to meet the different requirements for traction or resistance to impact and stress.



FAST LOADING CYCLE

The job has never been so easy!

Curved front loader arms improve truck loading while mechanical self-levelling assists the operator. Return-to-dig function significantly reduces the operator effort on repetitive loading operations and speeds up the whole cycle. Excellent front loader visibility and the mechanical self-levelling feature make loading and unloading pallets really quick and simple.



CAB AND SEAT



CAB AND SEAT

A CAB FIT FOR A KING



COMFORTABLE AND SAFE CAB

Get settled on your seat

- Pilot control columns and wrist rests are fully adjustable to suit your size.
- The cab sits on insulating mountings, reducing vibration and noise levels to 77 dB(A)
- Excellent visibility equals greater safety: the rear screen is fully tiltable to provide an unobstructed view of the digging area. The stowed rear screen also provides rain protection in the open position.
- Lumbar adjustment and fully adjustable armrests ensure a comfortable position throughout the working day.
- All four cab windows can be opened partially or fully, to provide maximum ventilation in the cab.
- A new overhead radio position and document storage box, combined with a lockable storage compartment make the CASE cab your comfortable office.
- Wide steps and sturdy grab handles make it easy to get in and out of the cab. Large door apertures without obstacles make access to the seat equally easy.

For night working the CASE backhoe loader comes with 10 working lights, including two on each side, for maximum visibility.



A single control joystick for all the loader functions

- Raise/lower the loader
- Bucket tilt
- Proportional control of the closing and opening of the 4-in-1 bucket or other hydraulic accessories
- Floating bucket position
- Differential lock (except on the 695ST, which features a limited slip differential)
- Cut off transmission switch
- Automatic return to dig position



Rear pilot joystick as option.
Standard: mechanical controls.



SPECIFICATIONS

	580T	580ST	590ST	695ST
ENGINE	Conform to 97/68/CE Tier 3 standards for reduced pollution - 4 cylinders Turbocharged 4,5 liter			
Injection system	Direct Mechanical	High pressure Common Rail	High pressure Common Rail	High pressure Common Rail
Make	CNH 445TA/ML5	CNH 445TA\EEA	CNH 445TA\EGH	CNH 445TA\EGH
Power (according to ISO 14396)	72 kW / 97 hp	72 kW / 97 hp	82 kW / 110 hp	82 kW / 110 hp
Maximum torque (according ISO 14963)	400 Nm @ 1400 1/min	453 Nm @ 1400 1/min	516 Nm @ 1400 1/min	516 Nm @ 1400 1/min
TRANSMISSION				
Powershuttle				
Forward speeds	6-10-21-40 Km/h	6-10-21-40 Km/h	6-10-21-40 Km/h	-
Reverse speeds	7-12-25-47 Km/h	7-12-25-47 Km/h	7-12-25-47 Km/h	-
Powershift				
Forward speeds	-	6 - 10 - 22 - 39 Km/h	6 - 10 - 22 - 39 Km/h	6 - 10 - 22 - 39 Km/h
Reverse speeds	-	7 - 12 - 26 Km/h	7 - 12 - 26 Km/h	7 - 12 - 26 Km/h
HYDRAULICS				
Type of pump and flow	Twin Gear Pump 151 l/min @ 2200 rpm	Variable Displ. 6 to 156 l/min @ 2200 rpm Twin Gear Pump 151 l/min @ 2200 rpm	Variable Displacement 6 to 165 l/min @ 2200 rpm	Variable Displacement 6 to 165 l/min @ 2200 rpm
Maximum pressure level	205 bars	205 bars	205 bars	205 bars
BATTERY	12 Volts / 12V 95Ah, 900A (SAE) / 120 A			
OPERATING WEIGHT	In sideshift version, with the standard tooth loader bucket, 610 mm rear bucket, full fuel tank and 75 kg operator			
4 WD, standard dipper	7950 Kg	7950 Kg	8020 Kg	8740 Kg
4 WD, extendible dipper	8050 Kg	8050 Kg	8120 Kg	8840 Kg
TURNING RADIUS				
Front tires 12.5/80-18, wheel not braked, 4WD engaged	4300 mm at ext. edge of front tires - 5600 mm at bucket corner			
Turning radius 4WD (external radius)	With 18" tires: 4300 mm with brakes off 3600 mm with brakes on			With 28" tires: 8180 mm in 2WS mode with brakes off 6820 mm in 2WS mode with brakes on 4810 mm in 4WS mode with brakes off
AXLES, TIRES & BRAKE				
Brake	Power braking: brake with friction area of 2472 cm ²			
Tires	Tires must be multi-purpose, or industrial for hard terrain, or agricultural for loose terrain			
- Front tires	18" front with 26" or 28" rear	18" front with 26" or 28" rear	18" front with 26" or 28" rear	24" front with 24" rear
- Rear tires	20" front with 30" rear	20" front with 30" rear	20" front with 30" rear	28" front with 28" rear
Front axle: oscillation of +/- 11°	Differential lock	Differential lock	Differential lock	Limited-slip differential (Oscillation: +/- 8 deg.)
CAPACITIES				
Fuel tank	145 l	145 l	145 l	125.9 l
Cooling system	24 l	24 l	24 l	24 l
Hydraulic oil	122 l	122 l	122 l	118 l
Gear box oil: Power Shuttle 4 WD	20.8 l	20.8 l	20.8 l	20.8 l
PowerShift: Front axle 4WD Differential	6.5 l	6.5 l	6.5 l	10.5 l
Output stage	0.7 + 0.7 l	0.8 l + 0.8 l	0.8 l + 0.8 l	1.3 l + 1.3 l
Rear axle 4WD Total	21.2 l	21.2 l	21.2 l	11 l
EMISSIONS (g/kWh)				
CO2 emission	773	790	744	744
NOx emission	4.1	4.4	3.6	3.6
HC emission	0.1	0.1	0.1	0.1
CO emission	1.8	1.8	0.9	0.9
PM emission	0.26	0.25	0.13	0.13
NOx + HCNM emission	4.2	4.5	3.7	3.7
NOISE				
Internal dB(A)	77			
External dB(A)	102	102	103	103
VIBRATION LEVELS	Upper limbs 2.5 m/s ² - Abdomen 0.5 m/s ²			
CAB				
ROPS / FOPS	ISO3471 / ISO3164			

T-SERIES BACKHOE LOADERS

GENERAL DIMENSIONS

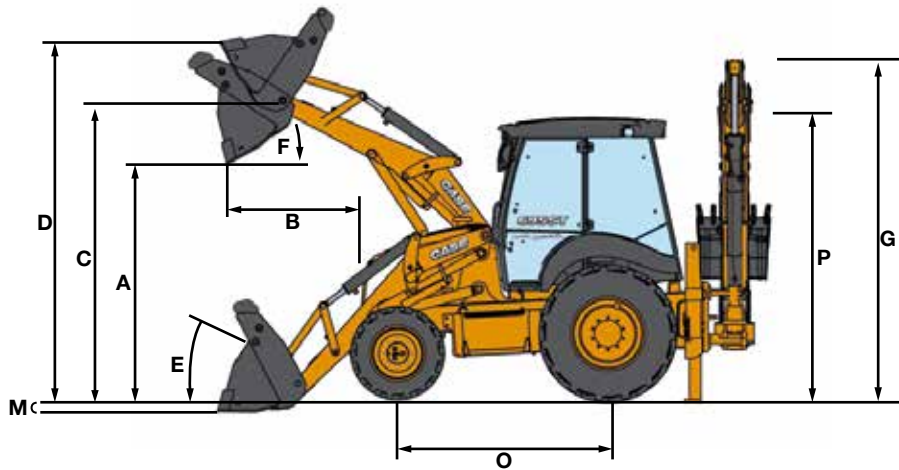

LOADER	580T		580ST	
	STRAIGHT	TOOL CARRIER	TOOL CARRIER	
A	Maximum dump height under bucket at 45°	2780 mm	2685 mm	2685 mm
B	Maximum reach with bucket at 45°	785 mm	830 mm	830 mm
C	Maximum height pin	3500 mm	3460 mm	3460 mm
D	Maximum bucket height	4405 mm	4250 mm	4250 mm
M	Horizontal bucket digging depth	75 mm	120 mm	120 mm
E	Bucket angle (on ground)	43°	43°	43°
F	Bucket angle (in the transport position)	46°	46°	46°
	Lift capacity (at bucket load centre of gravity)	4970 kg	4830 kg	4830 kg
	Maximum height lifting capacity	3550 kg	3450 kg	3450 kg
	Lift force (boom cylinders)	3625 daN	4050 daN	4050 daN
	Breakout force (bucket cylinders)	6340 daN	6545 daN	6545 daN

BACKHOE	EXTENDED	STD/RETRACTED	EXTENDED	STD/RETRACTED	
	Swinging angle	180°	180°	180°	180°
L	Maximum digging depth	5435 mm	4369 mm	5435 mm	4369 mm
I	Maximum reach from swing centre	6238 mm	5229 mm	6238 mm	5229 mm
	Maximum reach at rear axle	7563 mm	6554 mm	7563 mm	6554 mm
J	Maximum operating height	6789 mm	5875 mm	6789 mm	5875 mm
K	Load height	4834 mm	3923 mm	4834 mm	3923 mm
	Central offset	0.62 m	0.62 m	0.62 m	0.62 m
	Lift capacity at max outreach	1049 kg	1393/1296 kg	1049 kg	1393/1296 kg
	Breakout force (bucket)	5323 daN	5323 daN	5323 daN	5323 daN
	Breakout force (dipperstick)	2441 daN	3352 daN	2441 daN	3352 daN
R	Bucket rotation	200°/195° hyd. QC	200°/195° hyd. QC	200°/195° hyd. QC	200°/195° hyd. QC

DIMENSIONS			
G	Boom height (transport position)	3455 mm	3455 mm
	Overall length - with standard bucket	5560 mm	5560 mm
O	Wheelbase	2175 mm	2175 mm
P	Cab height	2950 mm	2950 mm
Q	Overall width - with standard bucket	2430 mm	2430 mm
	Width outside tires	2230 mm	2230 mm
S	Stabilizer leveling compensation angle	14°	14°

SPECIFICATIONS

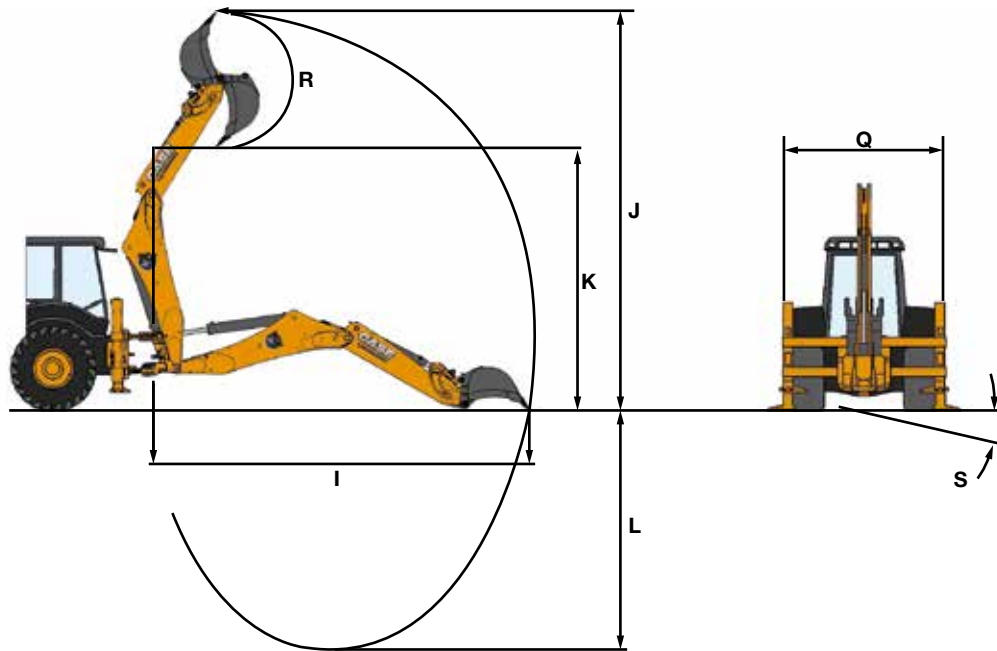

LOADER	590ST TOOL CARRIER	695ST TOOL CARRIER
A Maximum dump height under bucket at 45°	2685 mm	2717 mm
B Maximum reach with bucket at 45°	830 mm	744 mm
C Maximum height pin	3460 mm	3491 mm
D Maximum bucket height	4250 mm	4347 mm
M Horizontal bucket digging depth	120 mm	113 mm
E Bucket angle (on ground)	43°	45°
F Bucket angle (in the transport position)	46°	46°
Lift capacity (at bucket load centre of gravity)	4830 kg	4580 kg
Maximum height lifting capacity	3450 kg	3075 kg
Lift force (boom cylinders)	4050 daN	5411 daN
Breakout force (bucket cylinders)	6545 daN	3554 daN

BACKHOE	EXTENDED	STD/RETRACTED	EXTENDED	STD/RETRACTED
Swinging angle	180°	180°	180°	180°
L Maximum digging depth	5887 mm	4670 mm	5881 mm	4666 mm
I Maximum reach from swing centre (ground level)	6655 mm	5497 mm	6965 mm	5831 mm
J Maximum operating height	7141 mm	6111 mm	6348 mm	5616 mm
K Load height	5196 mm	4166 mm	4601 mm	3867 mm
Central offset	0.62 m	0.62 m	0.62 m	0.62 m
Lift capacity at max outreach	1097 kg	1472/1369 kg	1097 kg	1409/1276 kg
Breakout force (bucket)	6111 daN	6111 daN	5970 daN	5970 daN
Breakout force (dipperstick)	2488 daN	3482 daN	2388 daN	3358 daN
R Bucket rotation	198°/195° hyd. QC	198°/195° hyd. QC	203°/188° hyd. QC	203°/188° hyd. QC

DIMENSIONS

G Boom height (transport position)	3682 mm	3875 mm
Overall length - with standard bucket	5560 mm	5790 mm
O Wheelbase	2175 mm	2200 mm
P Cab height	2950 mm	2900 mm
Q Overall width - with standard bucket	2430 mm	2480 mm
Width outside tires	2230 mm	2230 mm
S Stabilizer leveling compensation angle	14°	14°



PARTS AND SERVICE

Wide network of customer support across the world.

No matter where you work, we're here to support and protect your investment and exceed your expectations. You can count on CASE and your CASE dealer for full-service solutions-productive equipment, expert advice, flexible financing, genuine CASE parts and fast service. We're here to provide you with the ultimate ownership experience.

To locate a CASE dealer or learn more about CASE equipment or customer service, go to <https://www.casece.com/apac/en-sea>.

NOTE: CASE provides specific outfits for various countries and many optional fittings (OPT). The illustrations on this or other leaflets may relate to standard or optional fittings. please consult your CASE dealer for any information in this regard and any possible updating on components. CNH Industrial reserves the right to modify machine specifications without incurring any obligation relating to such changes.

