

CASE

CONSTRUCTION

WHEELED EXCAVATOR **WX95 - Series 2**



Power	74 kW - 99 hp
Operating weight (max.)	10 000 kg
Bucket capacity	0.1 - 0.3 m ³

CLEAN PERFORMANCE

A powerful four cylinder Tier III engine offers 5% higher productivity and around 1% fuel saving over the previous Tier II model. Low noise output and reduced gaseous emissions make this an ideal machine for confined urban site operation.

Environmentally friendly. Highly productive.

TOTAL CONTROL

High specification hydraulic system offers simultaneous use of multiple functions for smooth digging and lifting performance. Electronic engine speed sensing control provides full use of the hydraulic pump output.

The machine comes with an automatic priority device with swing pressure control for outstanding controllability.

Smooth operation. Reduced fatigue.



CHASSIS VERSATILITY

Two or four wheel steering with crab steer facility to move the machine diagonally away from obstructions. Minimal turning circle of just 7.7 m. Customers can choose between rear blade, rear stabilisers, front blade and rear stabilisers or four stabiliser legs. Stabilisers and blade work independently controlled by the boom joystick. Maximum travel speed of 33 km/h or 20 km/h according to local regulations.

Agile performer. Operator control.

ERGONOMIC ENVIRONMENT

High space cab offers the same internal volume as larger excavators. Excellent all round visibility with tinted glass to all windows, including modular total or partial opening windscreen. Fully adjustable suspension seat and steering column ensure complete comfort for operators of all sizes. Majority of operating controls are located on joysticks, with forward and reverse movement controlled by the accelerator pedal.

Enhanced visibility. Ease of operation.



DESIGNED FOR PRODUCTIVITY

The compact Case WX upperstructure has a longitudinal mounted engine for a reduced tailswing radius. The slew function uses the main load sensing hydraulic system with an integrated automatic priority system and automatic static brake. Patented anti-drop valves standard on boom and dipper cylinders. A wide choice of booms and dipper arms is available and the boom foot has hydraulic articulation, allowing digging up to a wall or obstruction.

Robust design. Practical operation.

SERVICE ACCESS

Three lift up canopy doors around the rear and sides of the machine allow easy access to regular service and maintenance components. Tier III engine has 500 hour oil change intervals and all service points can be easily reached from ground level for technician safety. Ecological engine drain tap and hoses standard and biodegradable oil can be specified as an option.

Reduced downtime. Maximum productivity.

UPPERCARRIAGE



Designed as a compact midi class machine, the WX95 Series 2 has a very small rear overhang, with a tailswing radius of just 1485 mm. The longitudinal engine mounting ensures that service points are easily reached, despite this compact design, with ground level access to all regular maintenance areas. The machine has hydraulic boom offset to allow working against walls and other obstructions. With a choice of main boom and dipper arm lengths and specifications, the machine features patented anti-drop valves on main boom and dipper arm cylinders.

UNDERCARRIAGE



A two gear range transmission offers a maximum travel speed between job sites of 33 km/h. Maximum drawbar pull in low range is 62 kN. The WX95 Series 2 can be specified with two wheel steering or four wheel steering, and a choice of single or double wheels. In four wheel steering the machine offers a crab steering mode to allow diagonal movement away from a wall or obstruction, protecting the upperstructure and reducing the risk of impact on site.

ARTICULATED EQUIPMENT



The Tier III compliant WX95 Series 2 is designed to operate in confined spaces. Its full articulated boom, combined with a short radius upper structure, makes it possible for the machine to work in narrow urban applications. The standard offset boom allows the WX95 Series 2 to work alongside a wall or other obstruction. The boom itself is also articulated, enabling the operator to carry loads close in to the machine. The boom is equipped with a standard auxiliary hydraulic circuit to power additional hydraulic services, such as quick couplers, 4-in-1 buckets and hydraulic attachments.

OPERATOR'S CAB

The WX95 Series 2 uses the Case High Space cab, that offers similar internal volume to much larger excavators. The spacious environment is further improved by the extensive use of tinted glass to offer excellent all round visibility and a large transparent cab roof to allow additional light into the cabin. A fully adjustable suspension seat and tilting steering column ensure that operators of all sizes will be able to find a comfortable position in this exceptionally quiet cab. Simple to operate joystick controls and pedals ensure low effort and reduced fatigue for the operator over a full working day.



ENGINE



Electronically-controlled turbo charged diesel engine meets Tier III emissions regulations. In tests the 99 hp (74 kW) engine offers increased productivity and lower fuel consumption. Engine and hydraulic pump monitoring and control system offers multifunction use with high output, increasing productivity and tonne/litre output for the customer.

HYDRAULICS



Case has been a manufacturer of class-leading excavators for many years and the WX95 Series 2 builds on that success. The hydraulic system has on-board computer and engine speed sensor control to maximise hydraulic flow and pressure to meet the operator's needs. A swing pressure control offers the driver outstanding controllability, while the flow pump saving circuit minimises oil return to ensure smooth flowing movement of the boom and dipper arm.

SERVICE AND MAINTENANCE



Three large gullwing doors at the rear and side of the upperstructure afford excellent access to the engine and hydraulic components. All regular service work can be carried out from ground level and the Tier III engine has 500 hour oil change intervals to minimise downtime. The electronic management system incorporates self-diagnostic software that can be accessed via the large monitor in the cab. Standard ecological drain plugs and hoses are included and customers can opt for fully biodegradable oil if working in sensitive areas.







SPECIFICATIONS

ENGINE

Latest generation engine, meeting European requirements for "Low exhaust emissions" Tier III in accordance with directive 97/68/CE

Make _____ CASE FAMILY III
 Type _____ F4GE9484P*J/ 445TA/MNB
 4 cyl. 2 Val TAA rotary injection pump
 Number of cylinders _____ 4
 Bore - Stroke _____ 104 x 132 mm
 Displacement _____ 4.5 l
 Horsepower EEC80/1269 _____ 74 kW @ 2100 rpm
 Maximum Torque _____ 415 Nm @ 1250 rpm

HYDRAULIC SYSTEM

Total max. flow _____ 151 l/min
 Attachment max pressure _____ 350 bar
 Travel max pressure _____ 350 bar
 Swing max pressure _____ 190 bar

SWING

Max upperstructure swing speed _____ 8.0 rpm
 Swing torque _____ 23.0 kNm
 Tail swing radius _____ 1485 mm

TRAVEL

Max travel speed (field range) _____ 11 km/h
 Max travel speed (road range) _____ 33 km/h
 Max drawbar pull (field range) _____ 62 kN

ELECTRICAL SYSTEM

Voltage _____ 24 V
 Batteries _____ 2 x 12 V - 100 A/h
 Starter motor _____ 4 kW
 Alternator _____ 70 A

UNDERCARRIAGE

2 wheel steering turning circle diameter _____ 12.6 m
 4 wheel steering turning circle diameter _____ 7.7 m

CIRCUIT AND COMPONENT CAPACITIES

Fuel tank _____ 128 l
 Hydraulic tank _____ 94 l
 Engine oil _____ 13 l
 Cooling circuit _____ 22 l
 Swing gear _____ 3 l

BRAKES

Service brakes _____ oil bath disc type
 Work brake _____ acts on service brakes and locks front axle oscillation
 Parking brake _____ spring type mechanical acting on rear axle
 Emergency brake _____ double braking circuit and automatic parking brake actuation with the engine shut down

TYRES

4 wheels _____ 500/45 - 20
 8 wheels with twinning rings _____ 8.25 - 20

BUCKETS*

GENERAL PURPOSE

SAE capacity	l	96	135	193	237	280
Width	mm	350	450	600	700	800
Weight	kg	95	110	130	140	145

* For other bucket sizes, please contact your CASE dealer

SHIPPING DIMENSIONS AND WEIGHT

	PL			P2A			P2AL			P4A		
	Rear Blade			Rear Stabilisers			Front Blade + Rear Stab.			4 Stabilisers		
	max length mm	max height mm	kg	max length mm	max height mm	kg	max length mm	max height mm	kg	max length mm	max height mm	kg
Dipper 1.85 m	6970	3025	9550	6940	3025	9400	6940	3025	9950	6940	3025	9800
Dipper 2.20 m	7340	3025	9600	7310	3025	9450	7310	3025	10000	7310	3025	9850

GENERAL DIMENSIONS

Machine equipped with twin tyres 8.25-20 14PR

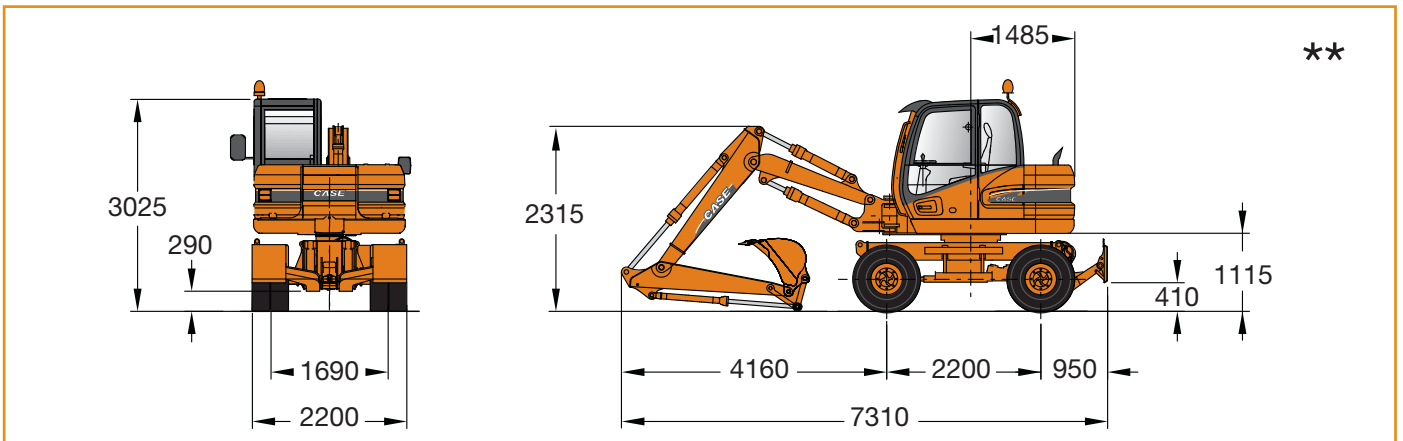
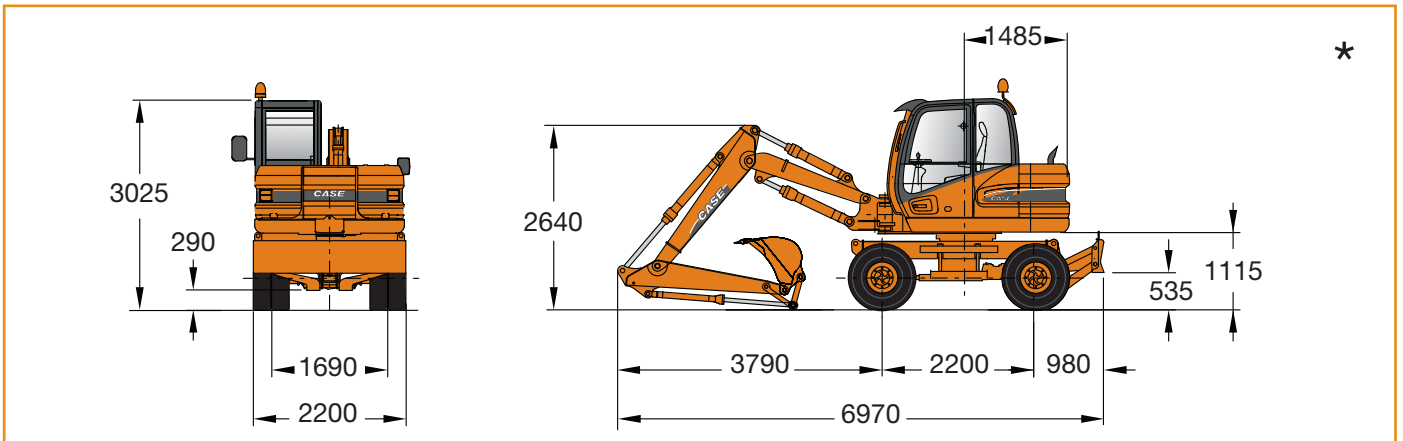
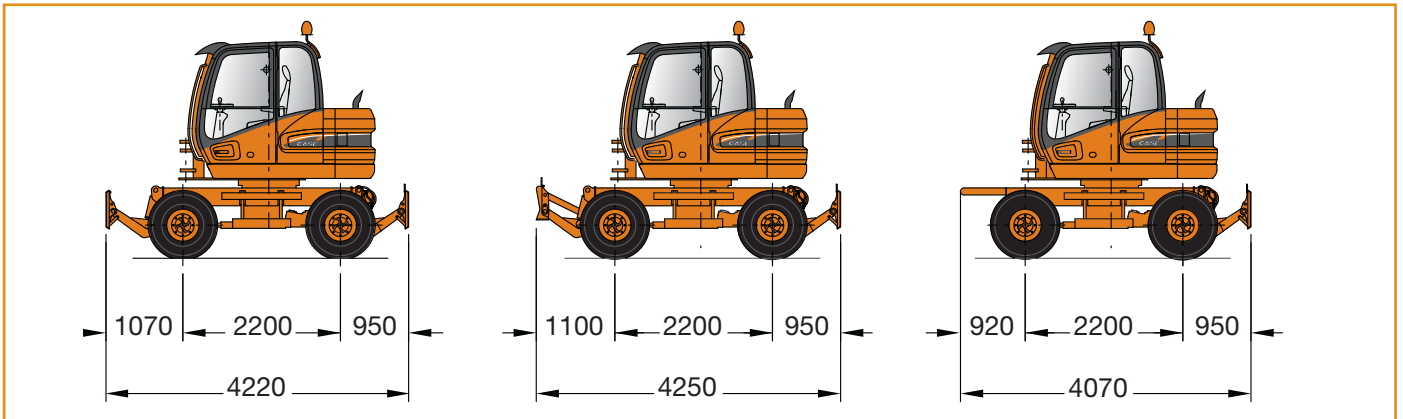

Dimensions are indicated in mm
 * Machine equipped with dipper 1850 mm long
 ** Machine equipped with dipper 2200 mm long

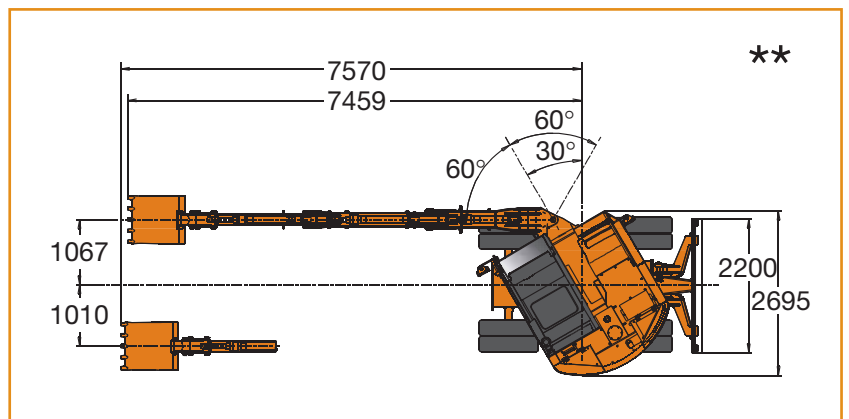

PERFORMANCE DATA

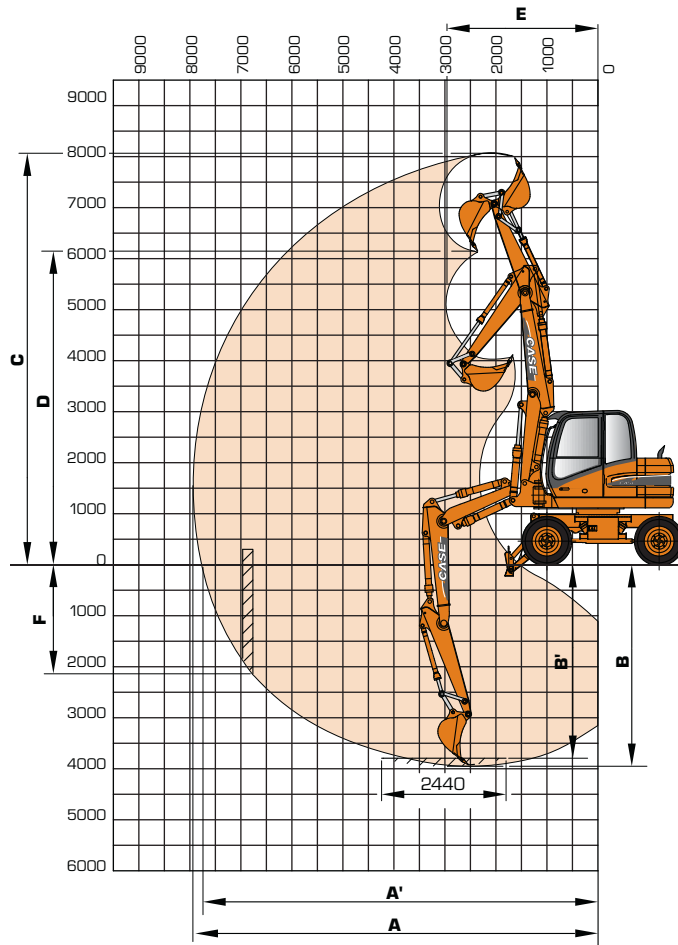

DIPPERSTICK

		1850 mm	2200 mm	
A	Maximum digging reach	mm	7941	8282
A'	Maximum digging reach at ground level	mm	7743	8095
B	Maximum digging depth	mm	3951	4298
B'	Digging depth - 2440 mm level bottom	mm	3793	4151
C	Max digging height	mm	8066	8397
D	Max loading height	mm	6147	6490
E	Minimum front swing radius	mm	2959	3189
F	Max digging depth of vertical wall	mm	2138	2403
	Bucket breakout force (350 bar)	daN	4600	4600
	Stick breakout force (350 bar)	daN	4530	4010

WX95 Series 2



LIFTING CAPACITY

BASE BOOM: 1.75 m - TOP BOOM: 2.00 m - BUCKET (CECE): 0.193 m³ (130 Kg)

Values are expressed in tonnes

Front 360°	REACH			
	3.5 m	4.5 m	6.0 m	At max reach m

PL up - DIPPERSTICK 1.85 m

6.0 m	2.9*	2.3	2.0	1.5	0	0	1.7	1.3	5.0
4.5 m	2.9*	2.3	2.0	1.5	1.2	0.9	1.1	0.8	6.3
3.0 m	2.8	2.1	1.9	1.4	1.2	0.9	1.0	0.7	6.9
1.5 m	0	0	1.8	1.3	1.2	0.9	0.9	0.7	7.1
0 m	2.4	1.7	1.7	1.2	1.1	0.8	0.9	0.7	6.9
-1.5 m	2.4	1.8	1.7	1.2	1.1	0.8	1.0*	0.8	6.2
-2.5 m	0	0	1.2	1.2	0	0	1.2	1.2	4.7

PL down - DIPPERSTICK 1.85 m

6.0 m	2.9*	2.7	2.5*	1.8	0	0	1.8*	1.5	5.0
4.5 m	2.9*	2.7	2.4*	1.8	2.0*	1.1	1.5*	1.0	6.3
3.0 m	4.0*	2.5	2.8*	1.7	2.1*	1.1	1.5*	0.8	6.9
1.5 m	0	0	3.2*	1.5	2.1*	1.0	1.6*	0.8	7.1
0 m	4.0*	2.1	3.0*	1.5	1.9*	1.0	1.4*	0.8	6.9
-1.5 m	2.6*	2.1	2.1*	1.5	1.2*	1.0	1.0*	1.0	6.2
-2.5 m	0	0	1.2	1.2	0	0	1.2	1.2	4.7

P2A down - DIPPERSTICK 1.85 m

6.0 m	2.9*	2.3	2.5*	1.5	0	0	1.8*	1.2	5.0
4.5 m	2.9*	2.3	2.4*	1.5	2.0*	0.9	1.5*	0.8	6.3
3.0 m	4.0*	2.1	2.8*	1.4	2.1*	0.9	1.5*	0.7	6.9
1.5 m	0	0	3.2*	1.3	2.1*	0.8	1.6*	0.7	7.1
0 m	4.0*	1.7	3.0*	1.2	1.9*	0.8	1.4*	0.7	6.9
-1.5 m	2.6*	1.8	2.1*	1.2	1.2*	0.8	1.0*	0.8	6.2
-2.5 m	0	0	1.2	1.2	0	0	1.2	1.2	4.7

P2AL down - DIPPERSTICK 1.85 m

6.0 m	2.9*	2.9	2.5*	1.9	0	0	1.8*	1.6	5.0
4.5 m	2.9*	2.9	2.4*	1.9	2.0*	1.2	1.5*	1.1	6.3
3.0 m	4.0*	2.6	2.8*	1.8	2.1*	1.2	1.5*	0.9	6.9
1.5 m	0	0	3.2*	1.7	2.1*	1.1	1.6*	0.9	7.1
0 m	4.0*	2.3	3.0*	1.6	1.9*	1.1	1.4*	0.9	6.9
-1.5 m	2.6*	2.3	2.1*	1.6	1.2*	1.1	1.0*	1.0	6.2
-2.5 m	0	0	1.2	1.2	0	0	1.2	1.2	4.7

P4A down - DIPPERSTICK 1.85 m

6.0 m	2.9*	2.4	2.5*	1.6	0	0	1.8*	1.3	5.0
4.5 m	2.9*	2.4	2.4*	1.6	2.0*	1.0	1.5*	0.9	6.3
3.0 m	4.0*	2.2	2.8*	1.5	2.1*	1.0	1.5*	0.8	6.9
1.5 m	0	0	3.2*	1.4	2.1*	0.9	1.6*	0.7	7.1
0 m	4.0*	1.9	3.0*	1.3	1.9*	0.9	1.4*	0.7	6.9
-1.5 m	2.6*	1.9	2.1*	1.3	1.2*	0.9	1.0*	0.9	6.2
-2.5 m	0	0	1.2	1.2	0	0	1.2	1.2	4.7

- Lift capacities are taken in accordance with SAE J 1097/ISO 10567/DIN 15019-2.
- Lift capacities shown in tons do not exceed 75% of the tipping load or 87% of the hydraulic lift capacity.
- Capacities that are marked with an asterisk are hydraulic limited.
- If the machine is equipped with a quick coupler, subtract the weight of the quick coupler from the load shown in the tables to calculate the real lifting capacity.
- The machine must be parked on firm, level ground, with stabilisers and/or blade on the ground.

LIFTING CAPACITY

BASE BOOM: 1.75 m - TOP BOOM: 2.00 m - BUCKET (CECE): 0.193 m³ (130 Kg)

Values are expressed in tonnes

Front 360°	REACH								
	3.5 m		4.0 m		6.0 m		At max reach		m

PL up - DIPPERSTICK 2.20m

6.0 m	0	0	2.0	1.5	0	0	1.4	1.1	5.5
4.5 m	0	0	2.0	1.5	1.3	0.9	1.0	0.8	6.7
3.0 m	2.8	2.1	1.9	1.4	1.2	0.9	0.9	0.6	7.3
1.5 m	0	0	1.8	1.3	1.2	0.9	0.8	0.6	7.5
0 m	2.4	1.7	1.7	1.2	1.1	0.8	0.9	0.6	7.2
-1.5 m	2.4	1.7	1.7	1.2	1.1	0.8	1.0	0.7	6.6
-2.5 m	0	0	1.2	1.2	0	0	1.2	1.2	4.9

PL down - DIPPERSTICK 2.20m

6.0 m	0	0	2.2*	1.8	0	0	1.5*	1.3	5.5
4.5 m	0	0	2.2*	1.8	1.9	1.1	1.3*	0.9	6.7
3.0 m	3.6*	2.5	2.7*	1.7	2.0*	1.1	1.2*	0.8	7.3
1.5 m	0	0	3.2*	1.6	2.1*	1.0	1.3*	0.7	7.5
0 m	4.4*	2.1	3.1*	1.5	2.0*	1.0	1.3*	0.8	7.2
-1.5 m	3.1*	2.1	2.4*	1.5	1.5*	1.0	1.0*	0.9	6.6
-2.5 m	0	0	1.2	1.2	0	0	1.2	1.2	4.9

P2A down - DIPPERSTICK 2.20m

6.0 m	0	0	2.2*	1.5	0	0	1.5*	1.1	5.5
4.5 m	0	0	2.2*	1.5	1.9	0.9	1.3*	0.8	6.7
3.0 m	3.6*	2.1	2.7*	1.4	2.0*	0.9	1.2*	0.6	7.3
1.5 m	0	0	3.2*	1.3	2.1*	0.8	1.3*	0.6	7.5
0 m	4.4*	1.7	3.1*	1.2	2.0*	0.8	1.3*	0.6	7.2
-1.5 m	3.1*	1.7	2.4*	1.2	1.5*	0.8	1.0*	0.7	6.6
-2.5 m	0	0	1.2	1.2	0	0	1.2	1.2	4.9

P2AL down - DIPPERSTICK 2.20m

6.0 m	0	0	2.2*	1.9	0	0	1.5*	1.4	5.5
4.5 m	0	0	2.2*	1.9	1.9	1.2	1.3*	1.0	6.7
3.0 m	3.6*	2.7	2.7*	1.8	2.0*	1.2	1.2*	0.8	7.3
1.5 m	0	0	3.2*	1.7	2.1*	1.1	1.3*	0.8	7.5
0 m	4.4*	2.3	3.1*	1.6	2.0*	1.1	1.3*	0.8	7.2
-1.5 m	3.1*	2.3	2.4*	1.6	1.5*	1.1	1.0*	1.0	6.6
-2.5 m	0	0	1.2	1.2	0	0	1.2	1.2	4.9

P4A down - DIPPERSTICK 2.20m

6.0 m	0	0	2.2*	1.6	0	0	1.5*	1.1	5.5
4.5 m	0	0	2.2*	1.6	1.9	1.0	1.3*	0.8	6.7
3.0 m	3.6	2.3	2.7*	1.5	2.0*	1.0	1.2*	0.7	7.3
1.5 m	0	0	3.2*	1.4	2.1*	0.9	1.3*	0.7	7.5
0 m	4.4*	1.8	3.1*	1.3	2.0*	0.9	1.3*	0.7	7.2
-1.5 m	3.1*	1.9	2.4*	1.3	1.5*	0.9	1.0*	0.8	6.6
-2.5 m	0	0	1.2	1.2	0	0	1.2	1.2	4.9

- Lift capacities are taken in accordance with SAE J 1097/ISO 10567/DIN 15019-2.
- Lift capacities shown in tons do not exceed 75% of the tipping load or 87% of the hydraulic lift capacity.
- Capacities that are marked with an asterisk are hydraulic limited.
- If the machine is equipped with a quick coupler, subtract the weight of the quick coupler from the load shown in the tables to calculate the real lifting capacity.
- The machine must be parked on firm, level ground, with stabilisers and/or blade on the ground.

WX95 Series 2

STANDARD EQUIPMENT & OPTIONS

STANDARD EQUIPMENT

- 2 wheel steering
- Robust, shielded arc-welded, modular chassis in box section design
- Large toolbox under the right step
- Latest generation CASE Family III Tier 3 diesel engines, comply with current European emissions standards
- Direct injection with turbo charger
- Water-cooled, low-consumption and low-exhaust compliant to EU directive
- Automatic battery main switch (coupled to ignition key)
- Pump Management System
- Hydraulic servo control
- Single pump hydraulic load sensing system with two service pumps
- Engine and pump monitoring by power limit control
- 6 selectable gears; maximum travel speed 33 Km/h
- Encased ball bearing slew ring with long-life lubrication
- Swing drive with low-wearing disc brake
- Noise-insulated and flexibly mounted cabin in soft design
- Tinted safety glazing all around, full up and over windshield
- Sun blinds, transparent roof and rain protection
- LCD with integrated error diagnosis function
- Steering column incline infinitely variable
- Ergonomic design of arm rests and foot pedals
- Driver suspension seat individually adjustable for height and incline
- Consoles adjustable for height and length
- Forward/Reverse shifting on accelerator
- Independent control of blade and each stabiliser
- Automatic axle locking system

- Travel and swing hydrostatic braking
- Centralised control of blade and stabilisers on right joystick
- Safety load hook on bucket linkage
- Patented safety valves for hoist mode
- Hydraulic system provision for hammer and shears

OPTIONS

- 4 wheel steering
- 20 km/h forward speed
- Single or twin tyres
- Dozer blade with hydraulic parallel guidance
- Stabilisers with large, lockable pads
- Transport holder for transport holder for clamshell grab
- Radio with 12 V electrical auxiliary supply in cab
- Front guard
- FOPS protection for cab
- Air conditioning
- Electric diesel filling system
- Cold starting kit
- Biodegradable oil
- Rotating beacon
- Piping for hammer and shears

Standard and optional equipment shown can vary by country.



CNH INTERNATIONAL SA
Riva Paradiso, 14
6902 Paradiso
SWITZERLAND

NOTE: Standard and optional fittings can vary according to the demands and specific regulations of each country. The illustrations may include optional rather than standard fittings - consult your Case dealer. Furthermore, CNH reserves the right to modify machine specifications without incurring any obligation relating to such changes.



Conforms to directive 98/37/CE

www.casece.com

CASE
CONSTRUCTION