

CASE

CONSTRUCTION

HYDRAULIC EXCAVATOR **CX290B**



Engine Horsepower	154 kW - 206 hp
Operating weight (max)	29.1 t
Bucket capacity	0.47 m ³ to 1.70 m ³

SMOOTH OPERATOR

Responsive hydraulic system with three working modes matches the power and speed to every application. Increased digging forces available with advanced Auto mode and Super Power mode. Rapid slew speeds and high swing torque result in fast cycle times and increased productivity.

Tier III compliant common rail engine combines fuel efficiency with increased horsepower. In combination with advanced hydraulic system results in significant fuel saving, cutting ownership costs and boosting profitability.

High Efficiency. Low Operating Cost.



STRIKING DESIGN

Tough, powerful appearance popular with operators, promoting high degree of satisfaction and boosting performance. New cab structure offers exceptional levels of comfort with ease of operation. Combined with advanced engine and hydraulic mode selection system, results in high productivity with reduced operator effort. Tier III emissions compliant engine uses less fuel and cuts gaseous emissions, improving the environment for all.

Ease of Operation. Environmentally friendly design.

BUILT TO WORK

Inherent durability is instantly obvious in all Case excavators. Robust upper structure and revised boom and dipper design with forged brackets offer strength and reliability. EMS bushes further increase durability, cutting ownership costs and boosting uptime working in difficult conditions. High performance synthetic fibre hydraulic filter protects the system and components, with no need for separate filters when the machine is used with a hydraulic breaker

Strength to perform. Designed to keep working.

LOWER OPERATING COSTS

The CX290B benefits from a larger fuel tank with a high flow auto stop refuelling pump. Combined with the common rail engine's lower fuel consumption and the highly efficient hydraulic system, this results in longer working periods between refills, of at least two days, boosting productivity. Extended Maintenance System (EMS) bushes offer 1,000 hour greasing intervals on the majority of pins, reducing downtime. Easy to maintain coolers, mounted side by side, and ground access centralised filter bank reduces service time, keeping your machine working. Low friction resin side shims on boom and dipper reduce wear and increase operator comfort through smoother operation.

Reduced ownership costs. Increased profitability.

OPERATOR COMFORT

Revised cab design provides additional leg and foot space. Significant increase in glass area contributes to spacious feeling for the operator. Reclining seat and air conditioning with multiple vents allows any operator to remain comfortable throughout the day. Storage includes hot/cold box, cup holder, mobile phone pocket and large box behind the operator's seat.

Temperature controlled cab is mounted on viscous couplings to reduce vibration and noise. With smooth intuitive controls this contributes to increase comfort and reduced operator stress.

Operator satisfaction. Maximum productivity.



INHERENT STRENGTH

New cab structure three times stronger yet has greater glass area for improved visibility all round, increasing safety inside the cab and outside on the job site. Single piece window to the operator's right offers excellent view to that side of the machine. Simple operating console makes the machine easier to work, with smooth responsive controls and easy to reach switches reducing operator fatigue and boosting productivity.

Safety first. Inside and out.



High pressure common rail engine exceeds Tier III emissions standards and is already equipped for the future move to Euro IV standards. Robust ladder frame design, with low speed torque, boosts durability for all components. Low engine speed contributes to lower noise output and improvement in fuel consumption. Large capacity exhaust muffer and large diameter low rev engine cooling fan further reduce engine noise. Standard fuel cooler helps to reduce fuel consumption, while four valve per cylinder engine design, using advanced exhaust gas recirculation (EGR) reduces gaseous emissions. Auto and one-touch idle speed allows the operator to control the engine for maximum efficiency.

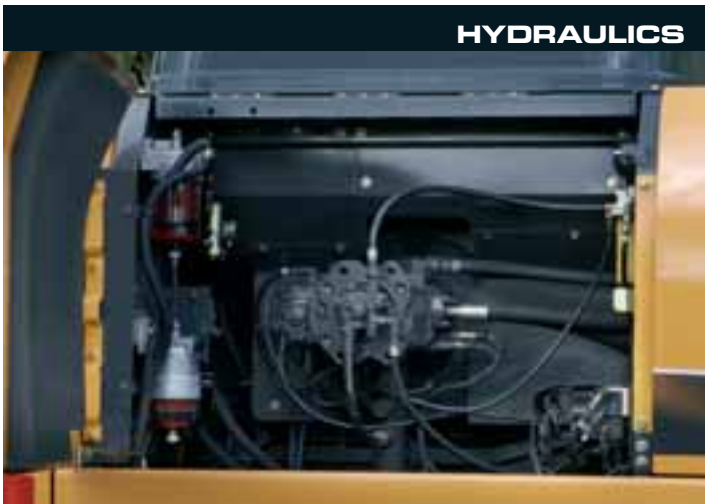

The CX290B builds on the Case heritage of excavator design. The machine has highly efficient piston type pumps to maximise pressure and flow. These are controlled by a variable control pump torque system that matches engine output to hydraulic demand, ensuring high productivity by rapidly reacting to servo lever movement. A high performance Super Fine synthetic fibre hydraulic filter ensures a high contamination catch, protecting valuable components. When the machine is used with a hydraulic breaker there is now no need for additional filters to be used, cutting cost for the customer.



Fully adjustable right hand console includes advanced engine throttle control, for working mode selection. A luminosity sensor in the console display ensures that the graphics are clear and easy to read in bright sunlight. Centralised layout of switches makes operation easier, while short lever joysticks further improve controllability. Advanced hydraulic system with up to 10 auxiliary hydraulic flow settings programmed into the memory, making it possible to use up to 10 attachments with no manual adjustment to hydraulic circuit. This means that the operator can change from a breaker setting of flow and pressure, to a shear setting from the seat.

OPERATOR'S CAB

Upgraded cab has slim pillars and more glass, including a single piece window on the right hand side, promoting improved visibility all round the machine and boosting safety. The main windscreen has a retractable sun visor and can be lifted into the roof space for a clear view of the digging area. Improvements in cab strength, combined with viscous cab mounts, result in low best in class levels of noise and vibration. Longer seat slides, adjustable consoles, increase in foot space, a fully reclining seat and air conditioning with nine outlet vents ensure that the operator stays comfortable and productive.

The cab is well appointed, with a clock, a large storage box behind the driver's seat, bottle and can holders, a mobile phone holder and a cool box that uses the air conditioning system to regulate internal temperature.



MAINTENANCE



Filters are centralised and remote mounted within large access panels, allowing ground level maintenance and reducing service time. Case excavators achieve the lowest score in SAE Maintenance score system, minimising downtime. The fuel tank has both a drain cock and a removable service plate, to allow for easy cleaning in the case of fuel contamination. A green engine oil drainer helps reduce environmental impact as there is no risk of spillage during draining. High flow electric refuelling pump is twice as fast as previous models, with an auto stop function to make refilling easier. Centralised greasing systems are available as an option.

UNDERCARRIAGE



Case undercarriage design has always promised long component life and low operating costs. The CX290B has heat treated drive sprockets for extended operation. Robust track guides and improved track links, with new M shaped seals and increased pin hardness, further boost durability and reliability. The track rollers have a revised profile for lower wear, and the O-ring design prevents the ingress of abrasive material, further extending longevity.

IMPROVED PIN AND BUSHING LIFE



Extended Maintenance Bushings (EMS) are now fitted as standard on all CXB excavators. Low maintenance EMS bushings provide 1,000 hour greasing intervals, greatly reducing daily and weekly servicing for the operator. The bucket pins retain a 250 hour greasing interval. Anti-friction shims in the boom foot and head reduce noise and cut free play, further increasing the Case reputation for durability and reducing ownership and operating costs.

EMS chrome plated pins with brass bushing

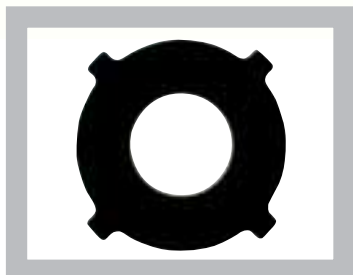

Anti-friction shims

ATTACHMENTS/BUCKETS

CX290B customers can choose from a variety of main booms and dipper arms to suit different applications, all of which are constructed of heavy duty steel box section with internal baffles to increase torsional rigidity. Deep groove welding ensures that the booms and arms can withstand the stress of high breakout forces, heavy lifting and attachments such as hydraulic breakers, compactors, demolition shears and crushers.

With a different choice of booms and dipper sticks, along with a range of buckets from 0.47m³ - 1.70 m³, there is a configuration to meet the requirements of every customer's job site.







SPECIFICATIONS

ENGINE

Latest generation engine, meeting European requirements for "Low exhaust emissions" Tier III in accordance with directive 97/68/EC
 Make _____ ISUZU
 Type _____ AH-6HK1XYSS
 Common rail, turbo, intercooler, fuel cooler GR (Exhaust Gas Recirculator) _____ Yes
 Direct injection _____ Electronically controlled
 Number of cylinders _____ 6
 Bore - Stroke _____ 115 x 125 mm
 Cubic capacity _____ 7790 cc
 Horsepower EEC80/1269 _____ 154 kw/206 hp @ 1800 rpm
 Maximum Torque _____ 850 Nm @ 1500 rpm

HYDRAULIC SYSTEM

Max output _____ 2 x 243 l/min @ 1800 rpm
 2 axial piston, variable flow pumps _____ Yes
 Attachment/Power Boost _____ 343/373 bar
 Upperstructure swing _____ 294 bar
 Travel _____ 343 bar
 Oil filtration _____ 6 micron
 Synthetic fiber _____
 Type of oil filter _____ Super fine High catch

SWING

Max upperstructure swing speed _____ 10.2 rpm
 Swing torque _____ 9250 daN

TRAVEL

The travel circuit is equipped with axial piston, variable flow motors
 Max travel speed _____ 5.6 km/h
 Low travel speed _____ 3.2 km/h
 Speed change is controlled from the instrument panel
 Automatic downshifting _____ Yes
 Gradeability _____ 70% (35°)
 Tractive force _____ 2332 daN

ELECTRICAL SYSTEM

Circuit _____ 24 V
 Batteries _____ 2 x 12 V - 128 A/h
 Circuit equipped with water-proof connectors _____ Yes
 Alternator _____ 24 V - 50 A

UNDERCARRIAGE

Upper rollers _____ 2
 Lower rollers _____ 9
 Number of track pads _____ 50
 Type of shoes _____ Triple grouser
 Track pad width Standard _____ LC/NLC - 700/600 mm
 Track guard _____ Front and 1 central

CIRCUIT AND COMPONENT CAPACITIES

Fuel tank _____ 450 l
 Hydraulic reservoir _____ 147 l
 Hydraulic system _____ 300 l
 Travel reduction gear (per side) _____ 9.1 l
 Swing reduction gear _____ 6 l
 Engine (including filter change) _____ 38 l
 Engine cooling system _____ 29 l

BUCKETS

GENERAL PURPOSE

SAE capacity	l	475	640	810	940	1060	1180	1300	1430	1550	1700
Width	mm	600	750	900	1000	1100	1200	1300	1400	1500	1600

HEAVY DUTY

SAE capacity	l	475	640	810	940	1060	1180	1300	1430	1550	1700
Width	mm	600	750	900	1000	1100	1200	1300	1400	1500	1600

DITCH WITH BLADE

SAE capacity	l	1010	1250	1210
Width	mm	2200	2200	2400

DITCH WITH TEETH

SAE capacity	l	1010	1250	1210
Width	mm	2200	2200	2400

HEAVY VERY DUTY

SAE capacity	l	1300
Width	mm	1300

QUARRY

SAE capacity	l	1500
Width	mm	1500

CX290B



GENERAL DIMENSIONS

WITH 6.15 m STANDARD MONOBOOM

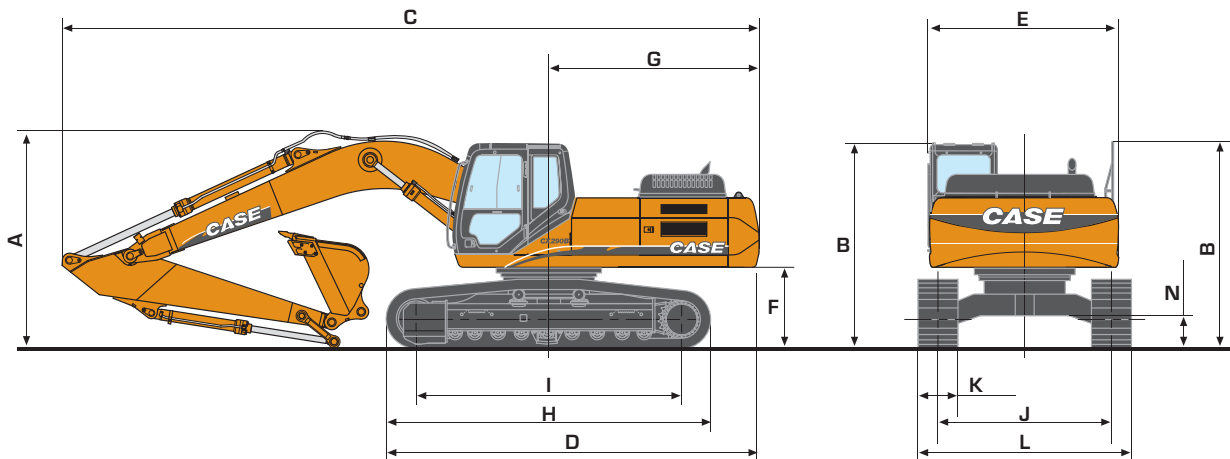

		CX290B LC MONO			CX290B NLC MONO			
		2.65 m	3.18 m	3.60 m	2.65 m	3.18 m	3.60 m	
DIPPER LENGTH								
A	Overall height (with attachment)	m	3.34	3.26	3.46	3.34	3.26	3.46
B	Height (cab/handrail)	m	3.07/3.11	3.07/3.11	3.07/3.11	3.07/3.11	3.07/3.11	3.07/3.11
C	Overall length (with attachment)	m	10.48	10.45	10.47	10.48	10.45	10.47
D	Overall length (without attachment)	m	5.59	5.59	5.59	5.59	5.59	5.59
E	Width of upperstructure	m	2.87	2.87	2.87	2.87	2.87	2.87
F	Upperstructure ground clearance	m	1.19	1.19	1.19	1.19	1.19	1.19
G	Swing radius (rear end)	m	3.15	3.15	3.15	3.15	3.15	3.15
H	Track overall length	m	4.85	4.85	4.85	4.85	4.85	4.85
I	Centre idler to centre sprocket	m	3.98	3.98	3.98	3.98	3.98	3.98
J	Track gauge	m	2.60	2.60	2.60	2.39	2.39	2.39
K	Track shoe width standard	mm	700	700	700	600	600	600
L	Track overall width - 600mm shoes	m	3.20	3.20	3.20	2.99	2.99	2.99
	- 700mm shoes	m	3.30	3.30	3.30	-	-	-
	- 800mm shoes	m	3.40	3.40	3.40	-	-	-
N	Ground clearance	m	0.47	0.47	0.47	0.47	0.47	0.47

WEIGHT AND GROUND PRESSURE

With 6.15 m standard monoboomb, 3.18 m dipper 880 kg, 1.1 m³ bucket operator and full fuel tank

	LC	NLC	LC	NLC
shoes 600 mm steel	29 100	29 100	0.56	0.56
shoes 700 mm steel	29 500	29 400	0.49	0.49
shoes 800 mm steel	29 800	-	0.43	-

CX290B

PERFORMANCE DATA

WITH 6.15 m STANDARD MONOBOOM - 3.18 m DIPPER

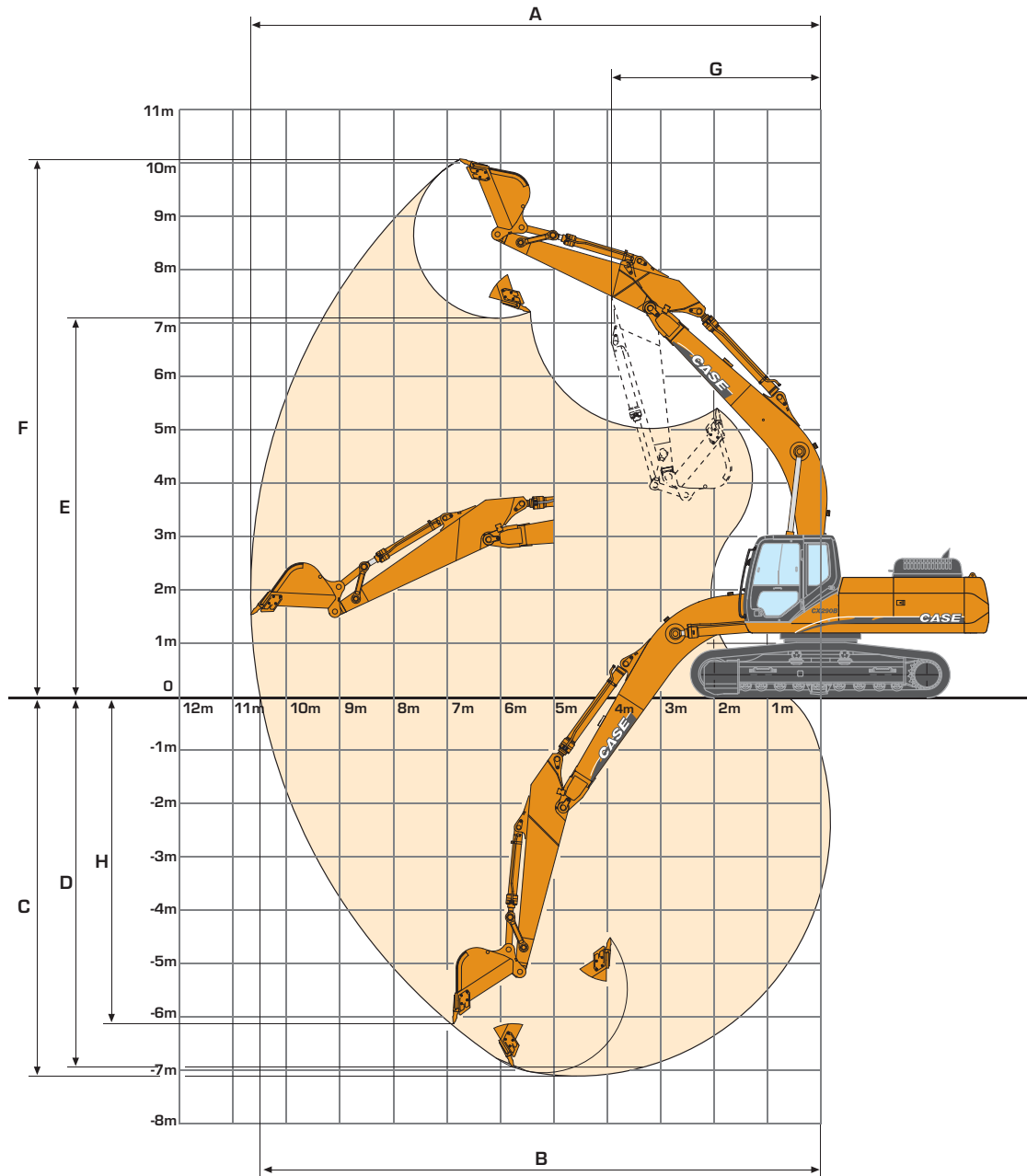

DIPPER LENGTH		2.65 m	3.18 m	3.60 m	
A	Maximum digging reach	m	10.22	10.67	11.16
B	Maximum digging reach at ground level	m	10.04	10.50	10.99
C	Maximum digging depth	m	6.57	7.10	7.58
D	Digging depth - 2,44 m level bottom	m	6.39	6.94	7.44
E	Max dump height	m	6.94	7.09	7.39
F	Overall reach height	m	9.93	10.06	10.39
G	Minimum swing radius - attachment	m	4.00	3.92	4.00
H	Vertical straight wall dig depth	m	5.76	6.12	6.72
Digging force					
	- w/o Power Boost	daN	14 020	12 160	10 980
	- with Power Boost	daN	15 300	13 240	11 870
Breakout force					
	- w/o Power Boost	daN	17 460	17 460	17 460
	- with Power Boost	daN	19 020	19 020	19 020



LIFTING CAPACITY

WITH 6.15 m STANDARD MONOBOOM

Values are expressed in kilos

Front 360°	REACH						m
	3.0 m	4.5 m	6 m	7.5 m	9.0 m	At max reach	

LC with 3.66 m dipper, 700 mm shoes and bucket of 1.0 m³ - 790 kg

7.5 m							4206 *	4206 *			3510 *	3510 *	7.82
6.0 m							5509 *	5509 *			3428 *	3428 *	8.71
4.5 m							6697 *	5345	4318 *	3861	3488 *	3488 *	9.27
3.0 m	17 854 *	17 854 *	11 434 *	11 434 *	8891 *	7284	7563 *	5085	5527 *	3728	3678 *	3344	9.56
1.5 m	8616 *	8616 *	14 177 *	10 523	10 310 *	6797	7678	4818	5728	3583	4021 *	3208	9.6
0 m	8681 *	8681 *	15 811 *	9893	10 592	6425	7435	4598	5598	3463	4584 *	3226	9.41
-1.5 m	11 392 *	11 392 *	16 184 *	9617	10 346	6211	7284	4461			5534 *	3422	8.96
-3 m	15 346 *	15 346 *	15 456 *	9580	10 276	6149	7249	4430			6335	3891	8.22
-4.5 m	19 035 *	19 035 *	13 530 *	9733	10 065 *	6242					8039	4926	7.07
-6 m	13 252 *	13 252 *	9675 *	9675 *							8053 *	7908	5.28

LC with 3.18 m dipper, 700 mm shoes and bucket of 1.1 m³ - 806 kg

7.5 m											4258 *	4258 *	7.17
6.0 m							5807 *	5491			4191 *	4191 *	8.13
4.5 m					8151 *	7682	7314 *	5313			4311 *	4076	8.73
3.0 m	16 268 *	16 268 *	12 497 *	11 298	9512 *	7217	7951	5074	4786 *	3741	4607 *	3715	9.04
1.5 m	6623 *	6623 *	14 994 *	10 406	10 819 *	6774	7685	4833	5632 *	3620	5121 *	3564	9.09
0 m	8682 *	8682 *	16 224 *	9904	10 611	6455	7476	4645			5772	3598	8.88
-1.5 m	12 411 *	12 411 *	16 202 *	9724	10 424	6291	7362	4542			6212	3853	8.4
-3 m	17 248 *	17 248 *	15 101 *	9751	10 406	6276	7374	4552			7230	4469	7.6
-4.5 m	17 383 *	17 383 *	12 708 *	9962	9430 *	6425					8739 *	5928	6.35
-6 m													

LC with 2.65 m dipper, 700 mm shoes and bucket of 1.30 m³ - 868 kg

7.5 m											5526 *	5526 *	6.59
6.0 m							7785 *	7785 *	5958 *	5373	5451 *	5216	7.62
4.5 m					10 696 *	10 696 *	8753 *	7528	7741 *	5216	5638 *	4413	8.26
3.0 m					13 456 *	10 968	10 029 *	7070	7863	4991	6072 *	3997	8.58
1.5 m					15 594 *	10 158	10 846	6656	7618	4771	6108	3831	8.64
0 m			7798 *	7798 *	16 323 *	9778	10 531	6382	7440	4610	6244	3886	8.42
-1.5 m			13 241 *	13 241 *	15 865 *	9691	10 401	6268	7367	4544	6804	4212	7.92
-3 m			19 540 *	19 540 *	14 360 *	9790	10 446	6307			8135	5010	7.06
-4.5 m			15 044 *	15 044 *	11 402 *	10 085					8936 *	7079	5.68
-6 m													

Machine in Auto mode

Lift capacities are taken in accordance with SAE J1097/ISO 10567/DIN 15019-2

Lift capacities shown in kg do not exceed 75% of the tipping load or 87% of the hydraulic lift capacity

Capacities that are marked with an asterisk (*) are hydraulic limited

If the machine is equipped with a quick coupler, subtract the weight of the quick coupler from the load shown in the table to calculate the real lift capacity

CX290B

Values are expressed in kilos

Front 360°	REACH										
	3.0 m	4.5 m	6 m	7.5 m	9.0 m	At max reach					m

NLC with 3.60 m dipper, 600 mm shoes and bucket of 1.0 m³ - 790 kg

7.5 m							4205*	4205*				3510*	3510*	7.82
6.0 m							5509*	5014				3428*	3428*	8.71
4.5 m							6698*	4820	4317*	3458		3489*	3266	9.27
3.0 m	17 858*	17 858*	11 435*	10 297	8892*	6548	7564*	4563	5526*	3327		3679*	2975	9.56
1.5 m	8613*	8613*	14 178*	9335	10311*	6072	7567	4301	5640	3184		4021*	2843	9.60
0 m	8681*	8681*	15 811*	8727	10439	5708	7324	4085	5510	3066		4586*	2852	9.41
-1.5 m	11 394*	11 394*	16 184*	8460	10193	5498	7172	3951				5477	3024	8.96
-3 m	15 349*	15 349*	15 456*	8424	10122	5438	7137	3920				6237	3442	8.22
-4.5 m	19 033*	17 214	13 529*	8572	10064*	5529						7920	4370	7.07
-6 m	13 248*	13 248*	9672*	8951								8053*	7026	5.28

NLC with 3.18 m dipper, 600 mm shoes and bucket of 1.1 m³ - 806 kg

7.5 m												4258*	4258*	7.17
6.0 m							5807*	4965				4191*	4191*	8.13
4.5 m					8151*	6939	7314*	4790				4311*	3656	8.73
3.0 m	16 268*	16 268*	12 497*	10 089	9512*	6484	7839	4554	4786*	3341		4607*	3317	9.04
1.5 m	6623*	6623*	14994*	9226	10 819*	6051	7573	4318	5632*	3221		5121*	3170	9.09
0 m	8682*	8682*	16224*	8741	10 458	5739	7365	4133				5682	3193	8.88
-1.5 m	12 411*	12 411*	16 202*	8566	10 270	5579	7251	4032				6117	3418	8.40
-3 m	17 248*	17 195	15 101*	8593	10 252	5564	7262	4042				7120	3968	7.60
-4.5 m	17 383*	17 383*	12 708*	8797	9430*	5710						8739*	5273	6.35
-6 m														

NLC with 2.65 m dipper, 600 mm shoes and bucket of 1.30 m³ - 868 kg

7.5 m														6.59
6.0 m												5526*	5526*	7.62
4.5 m					7785*	7147	5958*	4848				5451*	4704	8.26
3.0 m			10 696*	10 696*	8753*	6788	7741*	4694				5638*	3960	8.58
1.5 m			13 456*	9769	10 029*	6340	7751	4473				6072*	3570	8.64
0 m			15 594*	8985	10 692	5935	7507	4256				6015	3409	8.42
-1.5 m	7798*	7798*	16 323*	8618	10 378	5667	7329	4098				6149	3451	7.92
-3 m	13 241*	13 241*	15 865*	8533	10 247	5556	7256	4033				6701	3739	7.06
-4.5 m	19 540*	17 335	14 360*	8630	10 292	5594						8014	4452	5.68
-6 m	15 044*	15 044*	11 402*	8915								8936*	6295	

Machine in Auto mode

Lift capacities are taken in accordance with SAE J1097/ISO 10567/DIN 15019-2

Lift capacities shown in kg do not exceed 75% of the tipping load or 87% of the hydraulic lift capacity

Capacities that are marked with an asterisk (*) are hydraulic limited

If the machine is equipped with a quick coupler, subtract the weight of the quick coupler from the load shown in the table to calculate the real lift capacity



CX290B

STANDARD EQUIPMENT & OPTIONS

STANDARD EQUIPMENT

Engine control

- Common rail engine Tier III European Standards
- Electronic control of the injection system
- Automatic engine pre-heating
- Automatic/manual engine return to idle
- Exhaust Gas Recirculator
- Emergency stop
- Electrical refuel pump with automatic stop
- Fuel filter with water separator

Hydraulic control

- Auto/Heavy/Super Power working modes
- Pump torque variable control
- Automatic Power boost control
- Swing brake control
- High performance "Super Fine" synthetic fiber hydraulic filter (high contamination catch)
- Hydraulic safety valves on boom and dipper
- 2 travel speeds with auto down shifting

Operator environment

- High visibility cab with safety glass
- Adjustable and retractable armrest console with position memory
- Safety lever
- Self adjusting Air conditioning and heating system
- Cup holder
- High visibility side monitor display with automatic brightness
- Messages (function, temperature, safety, ...) on the display
- Integrated diagnostic system
- Working modes (Auto/Heavy/Super Power) combined with engine throttle
- Anti-theft device
- Hourmeter
- Selectable auxiliary hydraulic flow pre-settings
- RH front console with clock and cell phone holder
- High capacity shock absorbers on cab with 4 points fluid mountings
- Rain deflector
- Windscreen with lockable opening
- Windscreen washer and wiper
- Removable lower front windscreen with storage location in cab
- Glass cab roof window and sliding sun shade
- ISO control pattern low effort & short joysticks
- Adjustable sun visor

- Washable cab floor mat
- Rear view mirror and safety mirrors
- Storage compartments
- Integrated cool box
- 12V and 24V DC accessory sockets
- Hammer / Shear change selected from the cab
- Fore & aft adjustment of the whole seat & console

Electrical system

- Water proof connectors
- Double horn
- 2 working light on the cab
- Working light on the fuel tank
- Working light on the boom

Equipment

- EMS (Extended Maintenance System) pins and bushings as Standard (1000 hours lubrication interval for all, except buckets pins at 250 hours)
- Low friction resin side shims on boom and dipper
- Sealed and lubricated tracks
- Track guides (1 guide + front)
- Large tool box
- Pre-disposal for the optional cab protection

Operator seat

- Fully adjustable low frequency air suspension seat including double acting hydraulic damper
- Adjustable head rest
- Adjustable seat back angle with fully flat seat reclining
- Adjustable arm rest
- Adjustable lombar position
- Height/fore & aft adjustment
- Safety belt

OPTIONS

- Bucket/clamshell hydraulic circuit
- Hammer hydraulic circuit
- Hammer/shear hydraulic circuit
- Additional track guides (3 guides & front instead of 1 guide & front)
- Track width (600mm - 700mm - 800mm depending on the version)
- Windscreen protection
- Cab protection
- GPS (Global Positioning System) by satellite
- Centralized greasing system automatically actuated by an electrical grease pump

Standard and optional equipment shown can vary by country.

Worldwide Case Construction Equipment Contact Information

EUROPE:

via Plava, 80
10135 TORINO - ITALIA

AFRICA/ MIDDLE EAST/ CIS:

Riva Paradiso 14
6902 Paradiso - SWITZERLAND

NORTH AMERICA/ MEXICO:

700 State Street
Racine, WI 53404 U.S.A.

LATIN AMERICA:

Av. General David Sarnoff 2237
32210 - 900 Contagem - MG
Belo Horizonte BRAZIL

ASIA PACIFIC:

Unit 1 - 1 Foundation Place - Prospect
New South Wales - 2148 AUSTRALIA

CHINA:

No. 29, Industrial Premises, No. 376.
De Bao Road, Waigaoqiao Ftz, Pudong,
SHANGHAI, 200131, P.R.C.

NOTE: Standard and optional fittings can vary according to the demands and specific regulations of each country. The illustrations may include optional rather than standard fittings - consult your Case dealer. Furthermore, CNH reserves the right to modify machine specifications without incurring any obligation relating to such changes.

CASE Construction Equipment

CNH UK Ltd
Unit 4,
Hayfield Lane Business Park,
Field Lane, Auckland,
Doncaster,
DN9 3FL
Tel. 00800-2273-7373
Fax +44 1302 802829

www.casece.com

CASE
CONSTRUCTION



Conforms to directive 98/37/CE