

LOADER BACKHOE

CASE

CONSTRUCTION

SINCE 1842.

575SV

ENGINE

Brand	FPT
Model	S8000
Type	4-stroke, turbocharged diesel, Tier 3 certified
Cylinders	4
Bore/Stroke	104 x 115 mm (4.09" x 4.52")
Displacement	3.9 l (238 pol. ³)
Fuel Injection	Direct
Fuel	Diesel
Fuel Filter	with water separator
Cooling	Liquid
Engine Speeds (rpm)	
Rated Speed, full load	2.200
Idle	950 ± 50
Maximum speed, no load	2380 ± 50
Power at 2.200 rpm	
Gross	96 hp (72 kW)
Net	94 hp (70 kW)
Max Torque @ 1300 rpm	
Gross	420 N.m (310 lbf.pé)
Torque reserve	30% ± 5%
Note: Gross power and torque per ISO 14396	
Net power per	SAE J1349

TRANSMISSION

Transmission – 4WD		
Power Shuttle with 4 forward speeds and 4 reverse speeds		
Gear Ratio	Forward	Reverse
1 st	5.603	4.643
2 nd	3.481	2.884
3 rd	1.585	1.313
4 th	0.793	0.657

Travel speeds – km/h (mph)

	1 st	2 nd	3 rd	4 th
Advance	6.2 (3.9)	10.0 (6.2)	20.7 (12.9)	39.2 (24.4)
Reverse	7.4 (4.6)	12.0 (7.5)	24.8 (15.4)	Not recommended
Front tire				12.5x18
Rear tire				16.9x28
Torque converter				3.01
Conversion ratio				
4WD Front / Rear Axle				
Differential Ratio Planetary				2.286 / 2.466
Hub Ratio Total Reduction				6.0 / 6.9
Ratio				13.71 / 17.07

"Declutch" transmission release switches, one on the front panel and the other on the loader control lever

Service brakes	
Hydraulic drive with pedal, 2 discs per side.	
Disc area	228 pol. ² (1476 cm ²)

Parking brakes	
Manual, with lever	

Note: Service brake performance according to ISO 3450 standard

ENGINE COOLING

Radiator	
Core area	3048 cm ² (472 pol. ²)
Tube rows	4
Fan	
Type	5 paddle aspirant
Diameter	480 mm (19")
Ratio	1.38:1
Gradeability limited by the operation of the pump	
Side to side	35°
Forward-Backward	35°
Oil filter	Replaceable, flow (full), spin-on type

ELECTRIC SYSTEM

Voltage	12 V
Alternator	120 A
Battery	130Ah, 720 CCA

HYDRAULIC SYSTEM

Pump	Double gear pump
Backhoe main relief pressure	205 +/- 5 bar @ 145 l/min @ 2200 rpm 2973 +/- 73 psi @ 38.30 gal/min @ 2200 rpm

Filtration	10 µm element, return line, full flow, spin on type.
------------	---

Loader Control Valve	Sectional valve with two or three spools. The two spool valve has a single lever control for lift and tilt on a standard machine. The three-spool valve features a two-lever control, of which the first lever is for lift.
----------------------	--

Backhoe Mechanical Control Valve	Sectional valve with six or seven spools, closed center with parallel circuits.
----------------------------------	--

SERVICE CAPABILITIES

Fuel tank	129 l (34 gal)
Hydraulic System	
Total	107 l (28 gal)
Transmission – Total System	
4WD Standard	20 L (5,3 gal)
Axles - Total System	
Front Axle 4WD	8,9 l (2,35 gal)
Rear Axle	17,1 l (4,50 gal)
Engine oil with filter	8,6 l (2,27 gal)
Cooling System	20 l (5,3 gal)

LOADER

Single lever self-leveling and return-to-dig control

Mechanical loader valve lockout 4-function

Loader control of up to 3 functions, lifting, unloading and transmission uncoupling

Available buckets:

General Purpose Bucket with Bolt-On Teeth

Width	Capacity	Weight (empty bucket)
89" (2277 mm)	1,0 m ³ (1,31 yd ³)	450 kg (992 lb)
89" (2277 mm)	1,1 m ³ (1,44 yd ³)	470 kg (1036 lb)
89" (2277 mm)	1,2 m ³ (1,57 yd ³)	485 kg (1069 lb)

General Purpose Bucket without Teeth

Width	Capacity	Weight (empty bucket)
89" (2277 mm)	1,2 m ³ (1,57 yd ³)	460 kg (1014 lb)

6 in 1 HD Bucket with Bolt-On Teeth

Width	Capacity	Weight (empty bucket)
90" (2300 mm)	1 m ³ (1,31 yd ³)	560 kg (1235 lb)

BACKHOE

Mechanical control system with 2 levers

204° bucket rotation with mechanical coupler

Foot control for extendahoe

Stabilizer control

Available buckets

Width	Capacity	Weight (empty bucket)
305 mm (12")	0,08 m ³ (0,10 yd ³)	119 kg (262 lb)
457 mm (18")	0,12 m ³ (0,16 yd ³)	138 kg (304 lb)
610 mm (24")	0,18 m ³ (0,24 yd ³)	166 kg (366 lb)
762 mm (30")	0,26 m ³ (0,34 yd ³)	217 kg (478 lb)
914 mm (36")	0,30 m ³ (0,39 yd ³)	248 kg (547 lb)

OPERATING WEIGHTS

4WD equipped unit with 1m³ loader bucket, 0.30m³ backhoe bucket, 15' E-hoe arm, 12.5x18 front tire, rear tier 16.9x28, with operator (77kg), full fuel tank, light counterweight y ROPS/FOPS cab with AC.
7.861 kg (17.294 lb)

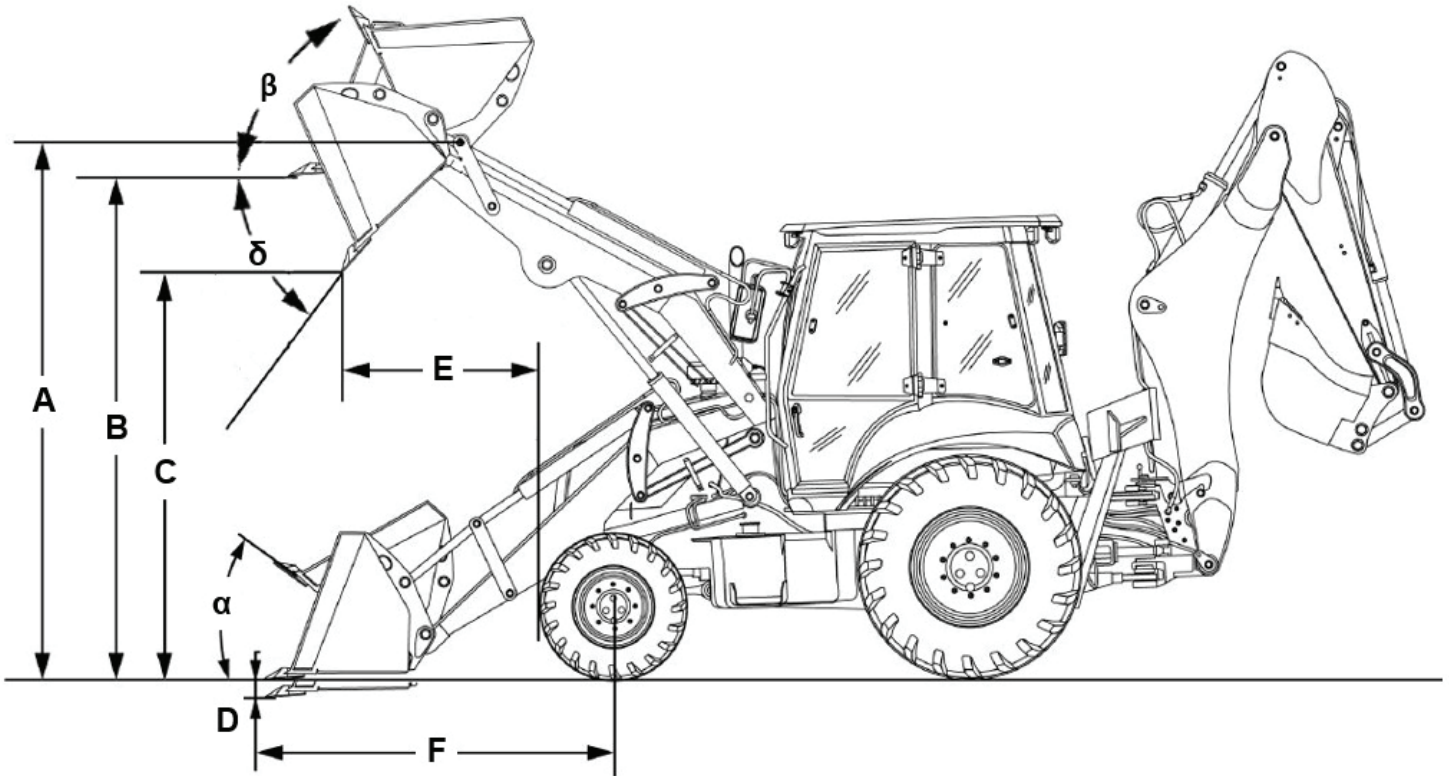

LOADER DIMENSIONS*

	Standard bucket	4 IN 1 Bucket
A Hinge pin height	3420 mm (11' 2,6")	3420 mm (11' 2,6")
B Load over height	3175 mm (10' 5")	3175 mm (10' 5")
̑ Dump angle	45°	45°
C Maximum dump height	2640 mm (8' 7,9")	2652 mm (8' 8,4")
E Dump reach at full height	855 mm (2' 9,6")	835 mm (2' 8,8")
Loader bucket rollback angles at ground line	43,2°	43,2°
D Dig depth below ground level	150 mm (5,9")	163,5 mm (6,43")
F Reach from front axle's center – bucket on ground	2010 mm (6' 7,1")	2035 mm (6' 8,1")
Lifting capacity to maximum height	3934 mm (12' 10,8")	3572 mm (11' 8,6")
Breakout force –		
Bucket	74,97 kN (17.528 lbf)	77,35 kN (17.388 lbf)
Arm	58,15 kN (13072 lbf)	58,60 kN (13173 lbf)

NOTE: Loader dimensions taken with 4WD rear tires, 16.9 x 28 - 12 ply.

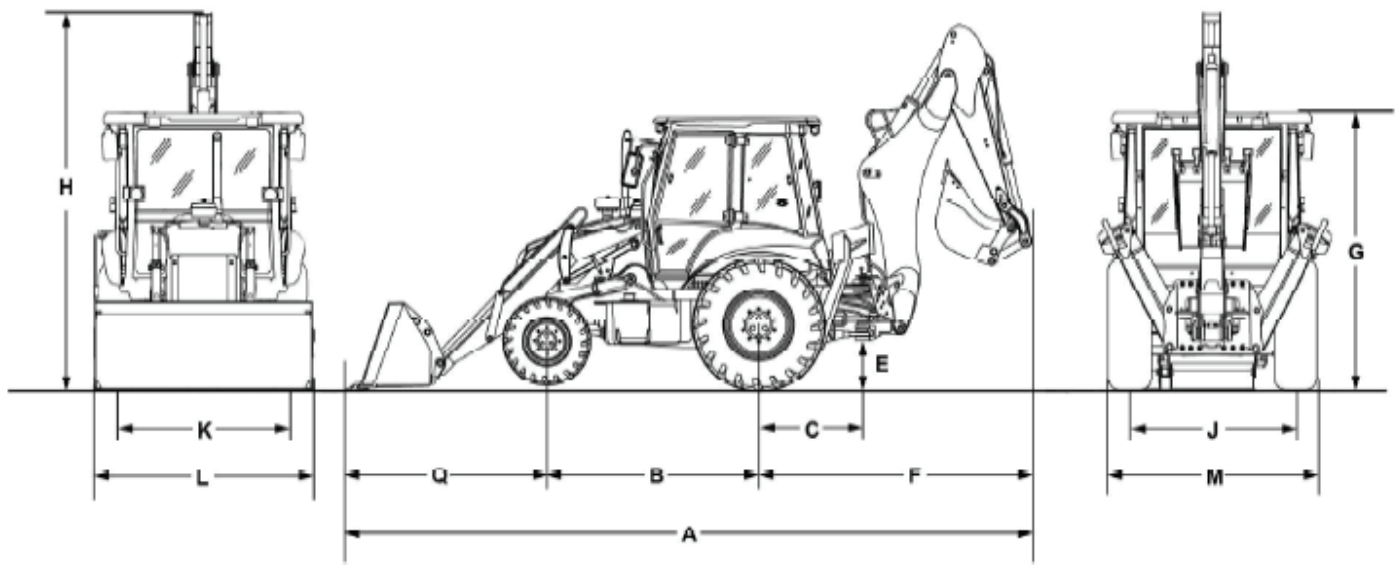

DIMENSIONS

	4WD with tires of 12,5 x 18 - 12 ply tires
A. Overall transport length	7190.0 mm (283.1 in)
B. Distance between axis	2175.00 mm (85.63 in)
C. Rotation center to rear axle center	1127.0 mm (44.4 in)
E. Pivoting ground clearance	500.0 mm (19.7 in)
F. Distance from rear wheel to bucket	3000.0 mm (118.1 in)
G. Height to the top of the cabin	2825.0 mm (111.2 in)
H. Transport height	3790.0 mm (149.2 in)
J. Track width-Rear	1697.2 mm (66.8 in)
K. Track Width-Front	1897.0 mm (74.7 in)
L. Overall transport width (bucket loader)	2277.0 mm (89.6 in)
M. Width over the stabilizer	2300.0 mm (90.6 in)
Overall transport length	7190 mm (19' 7,07")
Q. Reach to the ground	2011.0 mm (79.2 in), Bucket STD 1,0 cum
Overall transport width (bucket loader)	2277 mm (7' 5,6")
Height – To the top of the cabin	2825 mm (9' 3,2")
Transport	3790 mm (12' 5,21")
Wheelbase	2175 mm (7' 1,6")

CYLINDERS

	Cylinder diameter	Rod diameter	Stroke	Length closed
Loader				
Lift (2)	95,2 mm (3,75")	50,8 mm (2,00")	725 mm (28,54")	1000 mm (39,37")
Dump (2)	82,6 mm (3,25")	44,5 mm (1,75")	777 mm (30,59")	1020 mm (40,16")
Backhoe				
Arm	130 mm (5,12")	65 mm (2,56")	907 mm (35,71")	1207 mm (47,52")
Excavator arm	125 mm (4,92")	65 mm (2,56")	695 mm (27,4")	1009 mm (39,72")
Bucket	90 mm (3,54")	65 mm (2,56")	762 mm (30")	1073 mm (42,24")
14' Extendahoe®	75 mm (2,95")	45 mm (1,77")	1050 mm (41,34")	1400 mm (55,12")
15' Extendahoe®	75 mm (2,95")	45 mm (1,77")	1200 mm (47,24")	1550 mm (61,02")
Turn (2)	110 mm (4,33")	60 mm (2,36")	238 mm (9,4")	136 mm (5,36")
Stabilizer (2)	70 mm (2,76")	50 mm (1,97")	709 mm (27,91")	1081 mm (42,56")

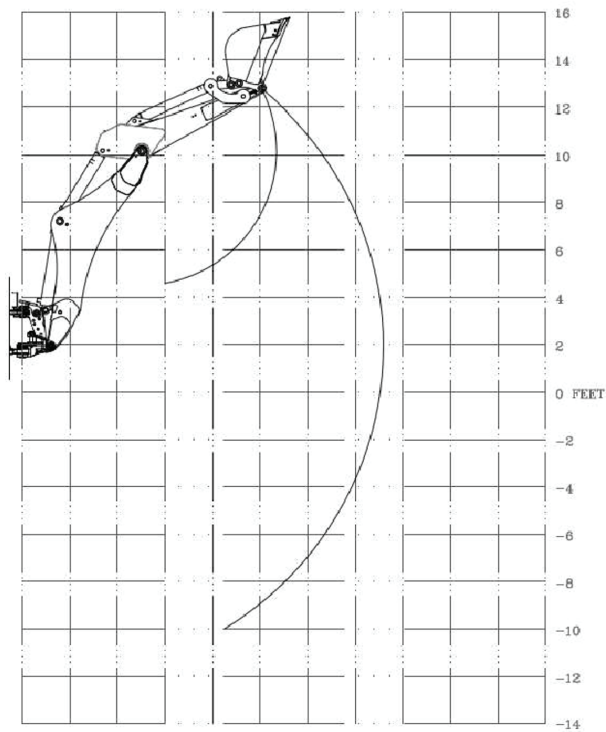

BACKHOE LIFT CAPACITIES

Arm 14'	Standard backhoe	Extendahoe®	
	Lift capacity of the backhoe – kg (lb)	Recolhido Lift capacity of the backhoe – kg (lb)	Estendido Lift capacity of the backhoe – kg (lb)
+5,2 m (17')	—	—	—
+4,9 m (16')	1.624 (3.573)	—	838 (1.844)
+4,3 m (14')	1.829 (4.024)	1.598 (3.516)	1.142 (2.513)
+3,7 m (12')	1.881 (4.138)	1.635 (3.597)	1.174 (2.583)
+3 m (10')	1.850 (4.070)	1.609 (3.540)	1.179 (2.594)
+2,4 m (8')	1.797 (3.954)	1.556 (3.423)	1.169 (2.572)
+1,8 m (6')	1.734 (3.815)	1.504 (3.309)	1.153 (2.537)
+1,2 m (4')	1.677 (3.690)	1.451 (3.192)	1.132 (2.491)
+0,6 m (2')	1.624 (3.470)	1.399 (3.078)	1.116 (2.455)
Ground level	1.530 (3.366)	1.357 (2.986)	1.095 (2.409)
-0,6 m (2')	1.499 (3.298)	1.315 (2.893)	1.079 (2.374)
-1,2 m (4')	1.472 (3.239)	1.279 (2.814)	1.069 (2.352)
-1,8 m (6')	1.467 (3.228)	1.252 (2.755)	1.058 (2.328)
-2,4 m (8')	1.520 (3.432)	1.242 (2.733)	1.058 (2.328)
-3 m (10')	1.605 (3.344)	1.273 (2.801)	1.074 (2.363)
-3,7 m (12')	1.624 (3.573)	1.404 (3.089)	1.121 (2.466)
-4,3 m (14')	—	—	1.300 (2.860)
-4,6 m (15')	—	—	1.603 (3.527)
Digging arm lift			
+4,3 m (14')	—	—	1.642 (3.613)
+3,7 m (12')	2.520 (5.544)	2.249 (4.948)	1.789 (3.936)
+3 m (10')	2.423 (5.331)	2.645 (5.819)	1.762 (3.877)
+2,4 m (8')	2.472 (5.439)	2.645 (5.819)	1.783 (3.923)
+1,8 m (6')	2.710 (5.962)	2.645 (5.819)	1.864 (4.101)
+1,2 m (4')	—	2.645 (5.819)	2.043 (4.495)
+0,6 m (2')	—	—	2.450 (5.390)
Ground level	—	—	—

BACKHOE LIFT CAPACITIES

Arm 15'	Standard backhoe	Extendahoe®	
	Lift capacity of the backhoe – kg (lb)	Retracted	Extended
Lift arm elevation	Lift capacity of the backhoe – kg (lb)	Lift capacity of the backhoe – kg (lb)	Lift capacity of the backhoe – kg (lb)
+5,2 m (17')	—	—	840 (1.848)
+4,9 m (16')	1.530 (3.366)	—	1.095 (2.409)
+4,3 m (14')	1.810 (3.982)	1.695 (3.729)	1.185 (2.607)
+3,7 m (12')	1.865 (4.103)	1.740 (3.828)	1.215 (2.673)
+3 m (10')	1.845 (4.059)	1.720 (3.784)	1.230 (2.706)
+2,4 m (8')	1.700 (3.740)	1.570 (3.454)	1.215 (2.673)
+1,8 m (6')	1.605 (3.531)	1.475 (3.245)	1.165 (2.563)
+1,2 m (4')	1.555 (3.421)	1.425 (3.135)	1.135 (2.497)
+0,6 m (2')	1.535 (3.377)	1.400 (3.080)	1.120 (2.464)
Ground level	1.545 (3.399)	1.410 (3.102)	1.120 (2.464)
-0,6 m (2')	1.585 (3.487)	1.445 (3.179)	1.140 (2.508)
-1,2 m (4')	1.575 (3.465)	1.415 (3.113)	1.150 (2.530)
-1,8 m (6')	1.560 (3.432)	1.395 (3.069)	1.145 (2.519)
-2,4 m (8')	1.560 (3.432)	1.385 (3.047)	1.150 (2.530)
-3 m (10')	1.605 (3.531)	1.415 (3.113)	1.165 (2.563)
-3,7 m (12')	1.855 (4.081)	1.630 (3.586)	1.210 (2.662)
-4,3 m (14')	—	—	1.325 (2.915)
-4,6 m (15')	—	—	1.910 (4.211)
Digging arm lift			
+4,3 m (14')	—	—	1.540 (3.388)
+3,7 m (12')	2.085 (4.587)	1.960 (4.312)	1.505 (3.311)
+3 m (10')	2.010 (4.422)	1.890 (4.158)	1.485 (3.267)
+2,4 m (8')	2.035 (4.477)	1.910 (4.202)	1.500 (3.300)
+1,8 m (6')	2.175 (4.785)	2.040 (4.488)	1.550 (3.410)
+1,2 m (4')	2.575 (5.665)	2.420 (5.324)	1.675 (3.685)
+0,6 m (2')	—	—	1.905 (4.191)
Ground level	—	—	2.250 (4.950)

BACKHOE OPERATING DATA

Arm 14'	Standard Backhoe	Extendahoe®	
		Retracted	Extended
Dig depth –			
Maximum	4,39m (14' 5,1")	4,54m (14' 11")	5,58m (18' 3,8")
Flat bottom of 610 mm (2')	4,34m (14' 3")	4,54m (14' 11")	5,57m (18' 3,6")
Flat bottom of 2.440 mm (8')	3,98m (13' 1")	4,19m (13' 9")	5,29m (17' 4,5")
Digging maximum reach	5,65m (18' 6,7")	5,79 m (19')	6,74m (22' 1,3")
Loading height	3,54m (11' 7,4")	3,64m (11' 11,5")	4,28 m (14' 0,5")
Loading Reach – Digging Arm	1,96m (6' 5,3")	2,05m (6' 8,7")	2,89m (9' 5,6")
Overall turning angle	180°	180°	180°
Rear bucket rotation angle –			
without coupling	160°	160°	160°
Stabilizer Width	2,30 m (7' 6,5")	2,30 m (7' 6,5")	2,30 m (7' 6,5")
Digging force –			
Bucket cylinder	56 kN (12.602 lbf)	56,1 kN (12.625 lbf)	56,1 kN (12.625 lbf)
Digging arm cylinder	42,8 kN (9.635 lbf)	40,3 kN (9.060 lbf)	29,3 kN (6.586 lbf)

Arm 15'	Standard Backhoe	Extendahoe®	
		Retracted	Extended
Dig depth –			
Maximum	4,70 m (15' 5,0")	4,70 m (15'5,3")	5,90 m (19' 4,2")
Flat bottom of 610 mm (2')	4,63 m (15' 2,4")	4,66 m (15' 3,5")	5,85 m (19' 2,3")
Flat bottom of 2.440 mm (8')	4,29 m (14' 1,0")	4,32 m (14' 2,2")	5,59 m (18' 3,9")
Digging maximum reach	5,93 m (19' 5,3")	5,94 m (19' 5,6")	7,02 m (23' 0,5")
Loading height	3,73 m (12' 2,7")	3,74 m (12' 3")	4,46 m (14' 7,5")
Loading Reach – Digging Arm	2,23 m (7' 4,0")	2,22 m (7' 3,4")	3,17 m (10' 4,8")
Overall turning angle	180°	180°	180°
Rear bucket rotation angle –			
without coupling	160°	160°	160°
Stabilizer Width	2,30 m (7' 6,5")	2,30 m (7' 6,5")	2,30 m (7' 6,5")
Digging force –			
Bucket cylinder	56,2 kN (12.620 lbf)	56,2 kN (12.620 lbf)	56,2 kN (12.620 lbf)
Digging arm cylinder	37,8 kN (8.494 lbf)	37,9 kN (8.512 lbf)	26,9 kN (6.058 lbf)

TIRES

Front part	4WD - 12,5/80 x 18 - 12 ply
Rear	4WD - 16,9 x 28 - 12 ply

OPERATOR ENVIRONMENT

ROPS/FOPS certified cabin
Note: ROPS, in compliance with ISO 3471 and FOPS in compliance with ISO 3164
Rear fender extensions
Left and right external mirrors
Internal rearview mirror
Toolbox
Left storage compartment
Ground accessible windshield washer filler door
Two access doors
Folding rear window
Mechanical suspension seat, 180 degree swivel, manual weight/height adjustment, pivoting armrests, tilting seat - seat belt of 2"
Front and rear wipers
Radio

INSTRUMENTATION

Indicators
Engine water temperature
Fuel level
Tachometer/hourmeter
Backlight gauges with illuminated pointers
Warning lights
Battery charge
Cold start
Transmission oil temperature
Brake oil level
Position lamp
Engine oil pressure
High beam indicator
Parking brake activation
Coolant high temperature
Hydraulic oil filter clogging
Sound alarms
Cold start
Transmission oil temperature
Brake oil level
Engine oil pressure
Parking brake activation
Coolant high temperature
Hydraulic oil filter clogging
Backup alarm
Horn – with double switch front and back
Direction indicators with switch
4 emergency indicators

TURNING DIAMETER

2WD drive	
Brakes activated	6,0 m (19' 8,2")
Brakes not activated	8,4 m (27' 6,7")
4 wheel drive – right turn	
Brakes activated	7,5 m (24' 7,3")
Brakes not activated	8,8 m (28' 10,5")
4 wheel drive – left turn	
Brakes activated	8,0 m (26' 3,0")
Brakes not activated	9,4 m (30' 10,1")
NOTE: Front tires 12.5/80 x 18 (4WD).	
External wheels for rear tire 16.9 x 28 (4WD).	

STANDARD EQUIPMENT

Operator compartment

See page 6

Engine

FPT S8000 diesel Tier 3 certified
Full flow engine oil filter
Air filter – dry type replaceable with radial seal
Non-spark protection muffler
Radiator with expansion tank
Antifreeze throttlers of -37 °C (-34 °F), both hand and foot activated
Self-adjusting belt tensioner
Mechanical fan with five paddles made of plastic

Loader

See page 2

Backhoe

See page 2

Powertrain

Front axle, depending model selection
Rear axle, depending on model selection
Without differential lock
Powershuttle with 4 speeds Forward and 4 speeds Reverse (transmission synchromesh)
Torque converter – 300 mm (11,8")
4WD Control in motion
Electric forward/reverse direction control

Hydraulic system

Closed center, load sensing
Pump of 145 l/min (38.3 gpm) at 2.200 rpm
Oil filter of 10 µm spin-on type
Heavy duty radiator hydraulic oil

Others

Tilt-forward engine hood
Front guard and heavy-duty grille tie-downs

Front lights:

2 AMBER turn signal lights, 2 individual 55W work lights and 2 individual driving lights (55W dimmed - 60W bright) with integrated 5W position

Taillights:

2 turn signals/flashers (21W) with integrated red stop lights and 4 individual 55W work lights
License plate lamp

OPTIONAL EQUIPMENT

1.2 m³ Toothless Loading Bucket
1.1 m³ and 1.2 m³ Loading Bucket with Teeth
4 in 1 and 6 in 1 HD Loading Buckets with Teeth Bolt-On
Rotating beacon
Front fenders
One-way hydraulic auxiliary driven by another additional lever. Flow from 0 to 160 l/min
Cold Starting auxiliary
Light or Heavy counterweight
Extendahoe arm
Mechanical quick coupling for rear bucket
Radial front tire 340/80
Radial rear tyre 440/80
Reversible shoes for stabilizers
15-foot digging arm
Open cabin



CASE Corporation reserves the right to make design improvements or changes in specifications at any time without obligation to install them on units previously sold. Specifications, descriptions, and illustrative materials contained in this document accurately reflect data known as of the date of publication, but are subject to change without notice. Illustrations may include optional equipment and accessories and may not include all standard equipment.

CCEIO143 – 07/2022 – (Manufacturing in India)

CaseCE.com



Commercial offices

ARGENTINA

Address: Ávalos 2829 Edif. 1 Piso
4º, Complejo Urbana Vicente
López (1605) Bs. As., Argentina.
Phone: +54 (11) 2034 1400

Manufacturing plants

BRASIL

Contagem – Minas Gerais
Address: Av. General David Sarnoff, 2237
Inconfidentes – C. P. 32210-900
Phone: +55 31 2104-3392

Sorocaba – São Paulo
Address: Av. Jerome Case, 1.801
Éden – CEP 18087-220
Phone: +55 15 3334-1700