

## 845B DIRECT DRIVE

### ENGINE

Brand	FPT
Model	F4HE9687W*J109
Type	Electronic, diesel, 4-stroke, direct injection, turbocharged, Tier 3 certified
Cylinders	6
Bore and stroke	4.09 x 5.19 in (104 x 132 mm)
Cylinder volume	408.86 in <sup>3</sup> (6,7 l)
Power @ 2200 rpm	
Gross (SAE J1995)	150/173 hp (112/129 kW)
Net (SAE J1349)	140/160 hp (104/119 kW)
Maximum torque @ 1500 rpm	
Gross (SAE J1995)	486/559 lbf.ft (659/758 Nm)
Net (SAE J1349)	436/500 lbf.ft (591/678 Nm)

### POWER TRAIN

Rear Axle	
Ground clearance	1 ft 3 in (380 mm)
Differential	Proportional torque
*Brakes	Disk, in oil bath
Number of disks per brake	5
Tandem	
Type	Welded plate
	7' 2,7" x 2' 0,8" x 8" (2204 x 631 x 201 mm)
Oscillation	20° in each direction
Command chain pitch	2 in (50,8 mm)
Thickness of internal and external side wall	0.75 in (19 mm)
Front axle	
Type	Welded high resistance steel
Oscillation	15° in each direction
Wheel lean	20° in each direction Ground
Clearance	1 ft 11 in (580 mm)
Tyres	14 x 24 12L- G2 sem câmara
Rims	9" (peça única)
*SAE J150 3450 (brake performance)	

### ELECTRICAL SYSTEM

Voltage	24 V (with grounding)
Alternator	90 A
Batteries	2x100 Ah – low maintenance
Lights	
	Front headlight with turn signals (2)
	Brake light and rear turn signals (2)
	Rear cab mounted work light (2)
	Front cab mounted work light (2)
Monitoring of electronic systems	

### HYDRAULIC SYSTEM

Type	Closed centre, load-sensing
Hydraulic pump	Axial piston pump, variable flow, equipped with load sensing system
Nominal Flow @ 2200 rpm	49 gpm (186 l/min)
Control valve	9 sections
Diagnostic couplers	8

### TRANSMISSION

Brand	FUNK	
Model	DF154E00DA	
Type	Direct Drive Powershift, electronic gear shift control, and slow forward pedal	
Rated flow @ 2.000 rpm	22.4 gpm (85 l/min)	
	Crankcase Integral	
Rated flow @ 2.200 rpm	29.5 gpm (112 l/min)	
Crankcase	Integral	
Drive gears	8 forward / 4 reverse	
Travel control	Electronic control, single "pulsing" lever and automatic module	
Fault diagnostics system	On-board	
Speeds – mph (km/h)		
	Forward	Reverse
1st	4.3 (2,7)	4.0 (2,5)
2nd	6.0 (3,7)	8.0 (5,0)
3rd	8.4 (5,2)	15.8 (9,8)
4th	11.7 (7,3)	31.0 (19,3)
5th	16.7 (10,4)	-
6th	23,1 (14,4)	-
7th	32.5 (20,2)	-
8th	44.8 (27,8)	-

## STEERING

Type	Hydrostatic steering
Angle - right and left	42°
Steering wheel turns (lock-to-lock)	4,5
Pump capacity @ 2200 rpm	11 gpm (42 l/min)
Pressure relief	2530 psi (17,5 MPa) built into the steering priority valve
Cylinders	2
Diameter	2 in (50,8 mm)
Stroke	11.8 in (301 mm)
Rod diameter	1 in (25,4 mm)
Supplemental steering	Built-in
SAE J53 e J1511	

## ARTICULATION

Type	Hydraulically driven (with lock out system)
Range	25° left/right
Controls	Hydraulic

## DRAWBAR

Type	"A" frame welded construction with centre mounted circle turn motor
Connection with the chassis	Shim adjustable ball stud

## CIRCLE

Type	Welded construction
Maximum outside diameter	5 ft 9 in (1752,6 mm)
Rotation	360°
Speed	1,2 rpm (7,2°/segundo)
Power drive	Hydraulic motor
Type	Gearmotor
Displacement	15.25 in <sup>3</sup> /rev (0.25 l/rev)
Nominal hydraulic flow	25 gpm (94.6 l/min)
Implement and with rear <i>ripper</i> plates	4

## CAPACITIES

Engine	4 gal (15 l)
With filter change	4.2 gal (16 l)
Fuel	90 gal (341 l)
Transmission	5.8 gal (26 l)
With filter change	7.5 gal (28,5 l)
Engine water cooling system	8.5 gal (32 l)
Hydraulic oil reservoir	23.8 gal (90 l)
Total hydraulic system	39,10 gal (148 l)
Circle gearbox	2.95 qt (2,8 l)
Tandem case (each)	18.2 gal (69 l)

## MISCELLANEOUS

Front counterweight	Without any front implement and with rear <i>ripper</i>
Saddle	5 positions

## MOLDBOARD

Type	High-carbon steel
Shape	Involute curve
Width	12 ft (3658 mm)
Height (curved profile)	2 ft 0.5 in (622 mm)
Thickness	0.86 in (22 mm)
Cutting edge	2, interchangeable
Blade pitch positions	
Normal pitch	47°
Minimum pitch	42°
Maximum pitch	87°
Blade shift Front section	
Right	2 ft 3 in (686 mm)
Left	1 ft 9 in (533 mm)
Maximum bank cutting angle	
Rear (left and right)	90°
Ground penetration (max.)	2 ft 4 in (711.2 mm)
Lift above ground (max.)	1 ft 5.5 in (444.5 mm)
Blade side shift and pitch	Hydraulic type

## SCARIFIER

Type	Front mounted
Width of cut	3 ft 10in (1168 mm)
Teeth	5 (optional, 11)
Spacing between the teeth	9 in (229 mm) 4.5 in (114 mm, optional)
Lift above ground	1 ft 8 in (527 mm)
Maximum penetration	1 ft 0.5 in (318 mm)
Weight	1256 lb (570 kg)

## OPERATING WEIGHT

With a blade of 12' (3658 mm), full tank, cab, headlights, STD batteries, 14x24 tire - 12L - G2, light *ripper* and front counterweight.

	33223 lb (15070 kg)
Weight, front axle	8891 lb (4033 kg)
Weight, rear axle	24332 lb (11037 kg)
Blade pull force	21898 lb (9933 kg)
Blade penetration force	15540 lb (7049 kg)
<i>Ripper</i> penetration force	17295 lb (7845 kg)

## CHASSIS

Type	Full welded box
Front section	
Size	10 x 11.7 in (254 x 298 mm)
Weight	338 lb/ft (153.3 kg/m)
Rear section	
Size	4.7 x 11.7 in (121 x 299 mm)
Weight	172.6 lb/ft (72.3 kg/m)

## REAR RIPPER

Type	Parallelogram
Cutting width	7 ft 1 in (2165 mm)
Teeth	
Lightweight Ripper	5 small
Medium Ripper	3 large + 5 small
Medium Ripper (optional)	+ 4 small
Lift above ground	
Lightweight <i>ripper</i>	2 ft 4 in (703 mm)
Medium <i>ripper</i>	
Large teeth	1 ft 8 in (518 mm)
Small teeth	2 ft 4 in (703 mm)
Maximum penetration	
Lightweight <i>ripper</i>	1 ft (306 mm)
Medium <i>ripper</i>	
Large teeth	1 ft 5 in (437 mm)
Small teeth	9.9 in (252 mm)
Weight	
Lightweight <i>ripper</i>	1433 lb (650 kg)
Medium <i>ripper</i>	1797 lb (815 kg)

## FRONT BLADE

Type	Front mounted
Width	9 ft 0.7 in (2762 mm)
Height	3 ft 1.5 in (953 mm)
Lift above ground	2 ft 0.4 in (622 mm)
Penetration	6.5 in (165 mm)
Weight	2568 lb (1165 kg)

## DIMENSIONS

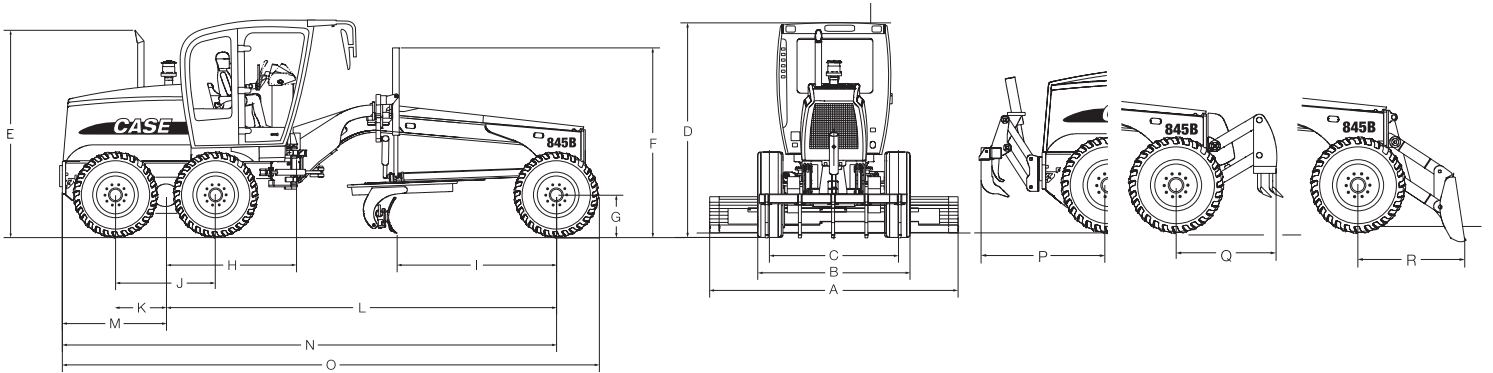

<b>A</b> – Blade width	12' (3658 mm)
<b>B</b> – Distance between wheels measured at outside of tires (Total width for transport)	8' 2" (2.495 mm)
<b>C</b> – Distance between the wheels	6' 9" (2.074 mm)
<b>D</b> – Height to top of cab	
High profile cab	11' 2" (3400 mm)
Low profile cab	10' 6" (3200 mm)
<b>E</b> – Height to top of engine exhaust pipe	10' 11" (3323 mm)
<b>F</b> – Height to top of the blade lift cylinder	10' (3047 mm)
<b>G</b> – Static tire radius	2' (610 mm)
<b>H</b> – Distance from centre of tandem to chassis pivot pin	6' 5" (1958 mm)
<b>I</b> – Distance between front axle and blade	8' 5" (2562 mm)
<b>J</b> – Distance between centre of rear tires	5' 2" (1572 mm)
<b>K</b> – Distance between centre of tandem and wheel	2' 7" (786 mm)
<b>L</b> – Wheelbase	20' 5" (6219 mm)
<b>M</b> – Distance between centre of tandem and rear section of the equipment	5' 5" (1650 mm)
<b>N</b> – Distance between the front wheel axle and the rear of the equipment	25' 10" (7868 mm)
<b>O</b> – Total length	28' (8534 mm)
<b>P</b> – Distance between rear tires and <i>ripper</i>	6' 9" (2028 mm)
<b>Q</b> – Distance between front tires and <i>ripper</i>	5' (1520 mm)
<b>R</b> – Distance between front tires and front blade	5' 4" (1626 mm)
Turning radius (outside the tires)	23' 9" (7250 mm)

All units equipped with 14.0 x 24-12L tires, ROPS/FOPS closed cab, standard battery, full fuel tank, operator weighing 165 lb (75 kg),, specifications per ISO 7134.

## STANDARD EQUIPMENT

### OPERATOR CAB

ROPS/FOPS high closed cab (fixed front window) with:  
Air conditioning (\*)  
Adjustable cloth mechanical suspension seat with 2 in (50.8 mm) seat belt  
Adjustable operator console  
Pedal accelerator  
Manual accelerator  
Front upper windshield wiper with washer  
Safety glass  
Dome light  
Internal and external rearview mirrors  
12 V socket (\*)  
Automatic master switch  
Steps on the right-hand and left-hand sides  
(\*) Only available in closed cabs

---

All ROPS/FOPS cabs are certified according to standards SAE J1040 (ROPS) and SAE J231(FOPS).

### ENGINE

FPT 6.7 L turbocharged, diesel  
Tier 3 certified  
Electronic fuel injection  
Dry air filter with primary and secondary safety elements  
Air pre-filter with cyclonic dust ejector  
90 A alternator  
5.4 hp (4.0 kW) starter motor  
Swing-up hood

### HYDRAULIC SYSTEM

Closed centre, load-sensing hydraulic system  
9-section control valve  
Hydraulic control for all functions:  
blade lifting (right and left side), circle turn, circle side shift, wheel lean, chassis articulation, blade side shift and pitch, front and rear accessories.  
Diagnostic centre with 8 quick couplers  
Movable saddle with 5 service positions and electro-hydraulic lock  
Blade 12' x 2' x 0.86" (3658 x 622 x 22 mm)  
Hydraulic axial piston pump  
Hydraulic motor fan

### BRAKES

Multi-disk oil-bathed service brakes with nitrogen accumulator safety system.  
Transmission-integrated disk parking brakes, with warning light.

### TYRES

9" one-piece rim/14 x 24 - 12L - G2  
Tubeless

### OTHER

Standard tool set  
Drawbar/ Standard circle

### AXLES

"Limited Slip" proportional torque differential (anti-slip system)

### STEERING

Hydrostatic steering with built-in emergency system

### INSTRUMENTS

Electronic Information centre  
Indicators/gauges:  
Speedometer  
Tachometer  
F/N/R direction selected  
Transmission modes – automatic/manual  
Selected Gear  
Engine coolant temperature  
Fuel level  
Transmission oil temperature  
Hydraulic oil temperature  
Hour meter  
Fuel consumption  
Engine diagnostics  
DeClutch activation indicator  
Transmission diagnostics

### INDICATOR LIGHTS

Low fuel level  
Flood lights  
High Beam  
Brake pressure  
Main alert  
Parking brake

### AUDIBLE ALERTS

Caution alert  
Emergency alert  
Reverse alarm

### ELECTRICAL SYSTEM

Lights  
Front headlight with turn signal (2)  
Brake light and rear turn signals (2)  
Rear cab mounted work light (2)  
Front cab mounted work light (2)  
24 V system (2 12 V / 1010 CCA batteries)  
Electronic systems monitoring  
Hooter  
Hour meter  
Reverse alarm

### TRANSMISSION

FUNK - DF154E00DA  
Transmission Direct Drive Powershift, electronic control of gear shift, automatic and pedal advance programmed, change protection down, inhibited investment. 8 forward speeds and 4 reverse speeds, parking brake 1' 2" (352 mm) dry disc, displacement control of potholes 24V.

### REAR IMPLEMENT

Lightweight *ripper* with 5 small teeth  
1433 lb (650 kg)

### FRONT IMPLEMENT

Front counterweight 1085 lb (492 kg)



**Conformities ISO  
Standards SAE**

Cab ROPS	SAE J1040
Cab FOPS	SAE J231
Power	
Gross	SAE J1995
Net	SAE J1349
Torque	
Gross	SAE J1995
Net	SAE J1349
Brakes	SAE J150/ISO-3450
Parking Brake	ISO-3450
Steering	SAE J53 / J1511
Additional steering	SAE 1011 / ISO-5010
Turning radius	ISO-7457
Hydraulic motor turning radius	SAE J499
Engine	
External noise	SAE 1372 / ISO-6393
Cab	
Internal noise	SAE J919

## OPTIONAL EQUIPMENT

### CAB (ROPS/FOPS)

Open cab  
Closed high cab (front flip-down window)  
Closed low cab (fixed front window)  
Closed low cab (front flip-down window)

### OTHER

Heater and fan for closed cab  
Acoustic insulation for closed cab  
Fire extinguisher  
Windshield washer and lower windshield wipers  
Rear windshield washer and wipers  
Radio  
Tandem locking device  
Sun visor (front and rear)  
Rear defroster

### FRONT IMPLEMENT

Dozer blade	2568 lb (1165 kg)
Light push plate	1085 lb (492 kg)
Heavy push plate	1764 lb (800 kg)
Front scarifier with 5 teeth 6 additional teeth for front scarifier	1521 lb (690 kg)
Dozer blade float electrovalve	

### REAR IMPLEMENT

Medium *ripper* with 3 large teeth and 5 small  
1796 lb (815 kg)

Rear pull hook  
Machine lifting bracket

### BLADE

Blade	13' x 2' x 0.86" (3962 x 671 x 22 mm)
Blade	14' x 2' x 0.86" (4267 x 671 x 22mm)
Right blade extension	2' (610 mm)
Left blade extension	2' (610 mm)
Heavy Duty cutting edge	Additional

### WORK LIGHTS

2 work lights behind the blade  
2 service lights in front of the mouldboard  
2 rear implement work lights

### LOCK/FLOATING/ANTI-SHOCK MOULDBOARD AND CIRCLE

Mouldboard lifting cylinder lock valve  
Mouldboard float electrovalve (incorporates lock valve)  
Anti-shock electrovalve with 2 accumulators for mouldboard  
Anti-shock electrovalve with 3 accumulators for mouldboard and circle

### SEAT/SAFETY BELT

Vinyl seat with mechanical suspension  
Cloth seat with air suspension  
Seat belt 76.5 mm (3")

### OTHER OPTIONAL ITEMS

Beacon light  
Luxury tool box  
Toolbox without tools with support, fixed on front chassis  
Slow moving vehicle sign  
Electric pump to inflate tires  
Spare tire cradle  
Axle  
Convenciona differential with four-wheel braking and differential lock with electro-hydraulic power drive (rear axle).

### TIRES AND MOUNTED RIMS

Tubeless tires  
10" rim – 3-piece / 14x24 tire – 12L – G2  
13" rim – one-piece / 17.5x25 tire – 12L – L2  
14" rim – 3-piece / 17.5x25 tire – 12L – L2  
14" rim – 3-piece / 17.5x25 tire – 16L – L3

Tube tires  
9" rim – one-piece / 14x24 tire – 12L – G2  
10" rim – 3-piece / 14x24 tire – 12L – G2

Tubeless radial tires  
9" rim – single-piece / 14x24 tire – 12L – L2 – RADIAL XGLA2  
10" rim – 3-piece / 14x24 tire – 12L – L2 – RADIAL XGLA2

### RIMS

9" rim – one-piece with valve  
13" rim – one-piece with valve  
10" rim – 3-piece with valve  
14" rim – 3-piece with valve



Fleet monitoring and tracking management system through satellite or mobile phone

Case reserves the right to implement improvements in the project and alterations to the specifications at any time, without prior notice, and not being liable to install them in previously sold units. The specifications, descriptions and graphics correctly reflect the information known to this day in this publication. This information may vary in different regions and may be subject to changes without previous notice. The graphics may include equipment and optional accessories, and may not include all the standard units.

CCEIO116 – 03/2022 – Printed in Brazil

**CaseCE.com**



**Commercial Offices**

ARGENTINA

Ávalos 2829 Edif. 1 Piso 4°,

Complejo Urbana

Vicente López (1605) Bs. As., Argentina.

Tel: 54 (11) 2034 1400

**Factories**

BRAZIL

Contagem – Minas Gerais – Brazil

Av. General David Sarnoff, 2.237

Inconfidentes – C.P. 32210-900

Tel.: +55 31 2104-3392

Sorocaba – São Paulo – Brazil

Av. Jerome Case, 1.801

Éden – C.P. 18087-220

Tel.: +55 15 3334-1700