

845B SERIES 2

ENGINE

Brand	FPT
Model	F4HE9687W*J108
Type	Electronic, diesel, 4-stroke, direct injection, turbocharged, Tier 3 certified
Cylinders	6
Bore and stroke	4.09 in x 5.17 in (104mm x 132mm)
Cylinder volume	408.86 in ³ (6,7 l)
Power @ 2200 rpm	
Gross (SAE J1995)	150/173 HP (112/129 kW)
Net (SAE J1349)	140/160 HP (104/119 kW)
Maximum torque @ 1500 rpm	
Gross (SAE J1995)	486/560 lbf.ft (659/758 Nm)
Net (SAE J1349)	436/500 lbf.ft (591/678 Nm)

POWER TRAIN

Rear axle	
Ground clearance	1 ft 3 in (380 mm)
Differential	Torque proportioning
*Brakes	Disk, in oil bath
Number of disks per brake	5
Tandem	
Type	Welded panel
	7' 2.7" x 2' 0.8" x 8" (2204 x 631 x 201 mm)
Oscillation	20° in each direction
Command chain pitch	2 in (50,8 mm)
Thickness of inner and external side wall	0.75 in (19 mm)

Front axle

Type	Welded high resistance steel
Oscillation	15° in each direction
Wheel lean	20° in each direction
Ground clearance	1 ft 11 in (580 mm)
Tyres	14 X 24 - 10PR - G2
Rims	9" (Single piece)
*SAE J150 3450 (brake performance)	

ELECTRICAL SYSTEM

Voltage	24 V (with grounding)
Alternator	90 A
Batteries	2x100 Ah – low maintenance
Lights	
	Front headlight with turn signals (2)
	Brake light and rear turn signals (2)
	Rear cab mounted work light (2)
	Front cab mounted work light (2)
Monitoring of electronic systems	

HYDRAULIC SYSTEM

Type	Closed centre, load-sensing
Hydraulic pump	Axial piston pump, variable flow, equipped with load sensing system
Nominal flow @ 2200 rpm	49 gpm (186 l/min)
Control valve	9 sections
Diagnostic quick couplers	8

TRANSMISSION

Brand	ZF	
Model	ZF TC LOCK UP 6WG – 160	
Type	Torque converter with lock up (also functioning as Direct Drive) Powershift, electronic gear shift control, automatic, no inching pedal for progressive advance	
Rated flow @ 2.000 rpm	22.4 gpm (85 l/min)	
Crankcase	Integral	
Drive gears	6 forward / 3 reverse	
Travel control	Automatic electronic control, single "pulsing" lever and automatic module	
Fault diagnostics system	On-board	
Speeds – mph (km/h)		
	Forward	Reverse
1st	3.1 (5,0)	3.3 (5,3)
2nd	4.8 (7,7)	7.8 (12,6)
3rd	7.4 (11.9)	18.1 (29.2)
4th	11.4 (18.4)	-
5th	17.2 (27.7)	-
6th	26.6 (42.8)	-

STEERING

Type	Hydrostatic steering
Angle - right and left	42°
Steering wheel turns (lock-to-lock)	4,5
Pump capacity @ 2.200 rpm	11 gpm (41.8 l/min)
Pressure relief	2530 psi (175 bar) built into the steering priority valve
Cylinders	2
Diameter	2 in (50,8 mm)
Stroke	11.8 in (301 mm)
Rod diameter	1 in (25,4 mm)
Supplemental steering	Built-in
SAE J53 and J1511	

ARTICULATION

Type	Hydraulically driven (with lock out system)
Range	25° left/right
Controls	Hydraulic

DRAWBAR

Type	"A" frame welded construction with centre mounted circle turn motor
Connection with the chassis	Shim adjustable ball stud

CIRCLE

Type	Welded construction
Maximum outside diameter	5 ft 9 in (1752,6 mm)
Rotation	360°
Speed	1,2 rpm (7,2°/second)
Power drive	Hydraulic motor
Type	Roller Geroter
Nominal hydraulic flow	25 gpm (95 l/min)

CAPACITIES

Engine	4 gal (15 l)
with filter change	4.2 gal (16 l)
Fuel	95 gal (360 l)
Transmission	6.6 gal (25 l)
with filter change	6.9 gal (26 l)
Engine water cooling system	8.5 gal (32 l)
Hydraulic oil reservoir	23.8 gal (90 l)
Total hydraulic system	39.10 gal (148 l)
Circle gearbox	0.74 gal (2,8 l)
Tandem case (each)	18.2 gal (69 l)

MISCELLANEOUS

Front counterweight	With no front implement and with rear ripper
Sadle	5 positions

MOLDBOARD

Type	High-carbon steel
Shape	Involute curve
Width	12 ft (3658 mm)
Height (curved profile)	2 ft 0.5 in (622 mm)
Thickness	0.86 in (22 mm)
Cutting edge	2, Interchangeable
Blade pitch positions	
Normal pitch	47°
Minimum pitch	42°
Maximum pitch	87°
Blade shift	
Right	2 ft 3 in (686 mm)
Left	1 ft 9 in (533 mm)
Maximum bank cutting angle	
Rear (left and right)	90°
Ground penetration (max.)	2 ft 4 in (711,2 mm)
Lift above the ground (max.)	1 ft 5.5 in (444,5 mm)
Blade side shift and pitch	Hydraulic type

SCARIFIER

Type	Mounted on the front
Cutting width	3 ft 10 in (1168 mm)
Teeth	5 (optional, 11)
Spacing between teeth	9 in (229 mm) 4.5 in (114 mm, optional)
Lift above ground	1 ft 8 in (527 mm)
Maximum penetration	1 ft 0.5 in (318 mm)
Weight	1256 lb (570 kg)

OPERATING WEIGHT

With a moldboard of 12 ft (3658 mm), full tank, cab, headlights, STD batteries, 14x24 12L-G2, light ripper and front counterweight.

	34.006 lb (15.425 kg)
Weight, front axle	8.911 lb (4.042 kg)
Weight, rear axle	25.095 lb (11.383 kg)
Blade pull force	22.635 lb (10.267 kg)
Blade penetration force	15.155 lb (6.874 kg)
Ripper penetration force	17.209 lb (7.806 kg)

CHASSIS

Type	Full welded box
Front section	
Size	10 x 11.7 in (254 x 298 mm)
Weight	103,1 lb/ft (153,3 kg/m)
Rear section	
Size	7.48" x 12.87" (190 x 327mm)
Weight	72.0 lb/ft (107,2 kg/m)

REAR RIPPER

Type	Parallelogram
Cutting width	7 ft 1 in (2.165 mm)
Ripper teeth	5
Lift above ground	
Scarified teeth	2 ft 4 in (703 mm)
Maximum penetration	
Ripper teeth	1 ft (306 mm)
Weight	1.410 lb (640 kg)

FRONT BLADE

Type	Front mounted width
Width	9 ft 0.7 in (2762 mm)
Height	3 ft 1.5 in (953 mm)
Lift above ground	2 ft 0.4 in (622 mm)
Penetration	6.5 in (165 mm)
Weight	2568 lb (1165 kg)

DIMENSIONS

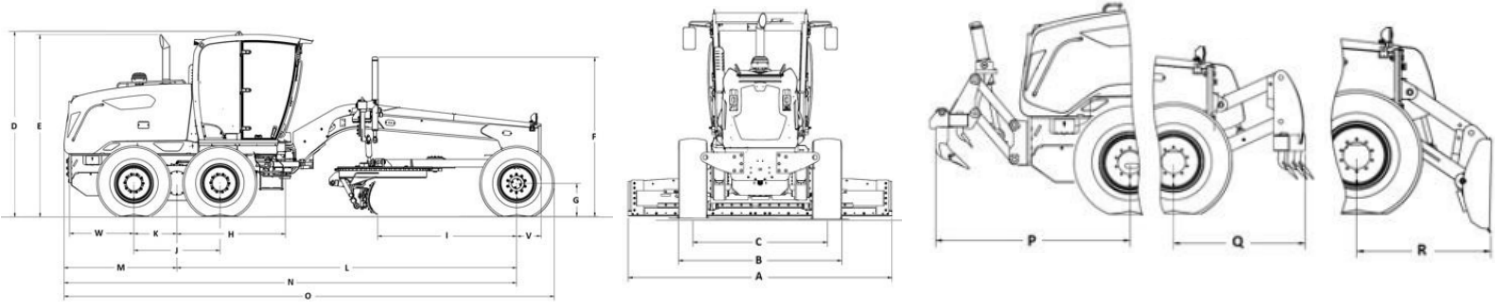

A – Blade width	12' 0" (3658 mm)
B – Distance between wheels measured at outside of tyres (Total width for transport)	8' 2.2" (2.495 mm)
C – Distance between the wheels	6' 9.6" (2.074 mm)
D – Height to top of cab High profile cab Low profile cab	11' 1.8" (3400 mm) 10' 6" (3200 mm)
E – Height to top of engine exhaust pipe	10' 10.8" (3323 mm)
F – Height to top of the blade lift cylinder	10' 0" (3047 mm)
G – Static tyre radius	2' 0" (610 mm)
H – Distance from centre of tandem to chassis pivot pin	6' 5" (1.958 mm)
I – Distance between front axle and blade	8' 5.0" (2562 mm)
J – Distance between centre of rear tyres	5' 1.9" (1571.8 mm)
K – Distance between centre of tandem and wheel	2' 6.9" (785.9 mm)
L – Wheelbase	20' 5" (6219 mm)
M – Distance between centre of tandem and rear section of the equipment	6' 9.3" (2064 mm)
N – Distance between the front wheel axle and the rear of the equipment	27' 2" (8283 mm)
O – Total length	29' 4.6" (8957 mm)
P – Distance between rear tyres and rear ripper	7' 2.5" (2196 mm)
Q – Distance between front tyres and front scarified	5' 0" (1513 mm)
R – Distance between front tyres and front blade	5' 4" (1619 mm)
Turning radius (outside the tyres)	23' 9" (7250 mm)

All units equipped with 14 x 24 12L - G2 tyres, ROPS/FOPS open cab, standard battery, full fuel tank, operator weighing 175 lb (79 kg), specifications per ISO 7134.

STANDARD EQUIPMENT

Operator Cab

ROPS/FOPS high closed cab (fixed front window) with:

- Air conditioning (*)
- Adjustable cloth mechanical suspension seat with 2" (50.8 mm) seat belt
- Adjustable operator console
- Pedal accelerator
- Manual accelerator
- Front upper windshield wiper with washer
- Dome light
- Internal and external rearview mirrors
- 12 V socket (*)
- Automatic master switch
- Steps on the right-hand and left-hand sides
- (*) Only available in closed cabs

All ROPS/FOPS cabs are certified according to standards SAE J1040 (ROPS) and SAE J231 (FOPS).

Engine

FPT 6.7 l turbocharged, diesel, Tier 3 certified

- Electronic fuel injection
- Dry air filter with primary and secondary safety elements
- Air pre-filter with cyclonic dust ejector
- 90 A alternator
- 10.5 hp (7.8 kW) starter motor
- Tilting hood with electric opening and closing

Hydraulic System

Closed centre, load-sensing hydraulic system

- 9-section control valve
- Hydraulic control for all functions:
 - blade lifting (right and left side), circle turn, circle side shift, wheel lean, chassis articulation, blade side shift and pitch, front and rear accessories
- Diagnostic centre with 8 quick couplers
- Movable saddle with 5 service positions and electro-hydraulic lock
- Blade 12' x 2' x 0.86" (3658 x 622 x 22 mm)
- Hydraulic axial piston pump
- Hydraulic engine fan

Brakes

Multi-disk oil-bathed service brakes applied on four rear wheels, with two parallel circuits: one for right tandem wheels and another for left tandem wheels. With nitrogen accumulator safety system.

Dry disc parking brakes, applied by spring and hydraulic release.

Tyres

9" Rim single piece / 14 x 24 - 12L - G2

Other

Standard tool set
Drawbar / Standard circle

Axes

Torque proportioning differential
Limited Slip

Steering

Hydrostatic steering with built-in emergency system

Instruments

Electronic Information Centre

Indicators/gauges:

- Speedometer
- Tachometer
- F/N/R direction selected
- Transmission modes – automatic/manual
- Selected Gear
- Engine coolant temperature
- Fuel level
- Transmission oil temperature
- Hydraulic oil temperature
- Hour meter
- Fuel consumption
- Engine diagnostics
- DeClutch activation indicator
- Transmission diagnostics

Indicator lights

- Low fuel level
- Flood lights
- High Beam
- Brake pressure
- Main alert
- Parking brake

Audible alerts

- Caution alert
- Emergency alert
- Reverse alarm

Electrical System

Lights

- Front headlight with turn signal (2)
- Brake light and rear turn signals (2)
- Rear cab mounted work light (2)
- Front cab mounted work light (2)

24 V system (2 12 V / 1010 CCA batteries)

- Electronic systems monitoring
- Hooter
- Hour meter
- Reverse alarm

Transmission

ZF Transmission, torque converter type with lock up (also functions as Direct Drive), Powershift, 6 forward and 3 reverse speeds, automatic gear shifting, emergency device in case of electrical failure (Limp-Home).

Rear Implement

Light ripper with 5 teeth

1.433 lb (650 kg)

Front Implement

Front counterweight

1.146 lb (520 kg)



Conformities ISO
Standards SAE

Cab ROPS	SAE J1040
Cab FOPS	SAE J231
Power	
Gross	SAE J1995
Net	SAE J1349
Torque	
Gross	SAE J1995
Net	SAE J1349
Brakes	SAE J150/ISO-3450
Parking Brake	ISO-3450
Steering	SAE J53 / J1511
Additional steering	SAE 1011 / ISO-5010
Turning radius	ISO-7457
Hydraulic motor turning radius	SAE J499
Engine	
External noise	SAE 1372 / ISO-6393
Cab	
Internal noise	SAE J919

OPTIONAL EQUIPMENT

Cabine (ROPS/FOPS)

Open cab
Closed high cab (front flip-down window)
Closed low cab (fixed front window)
Closed low cab (front flip-down window)

Other

Heater and fan for closed cab
Acoustic insulation for closed cab
Fire extinguisher
Windshield washer and lower windshield wipers
Rear windshield washer and wipers
Radio
Tandem locking device
Sun visor (front and rear)
Rear defroster

Front implement

Dozer blade	2568 lb (1165 kg)
Light push plate	1084 lb (492 kg)
Heavy push plate	1763 lb (800 kg)
Front scarifier with 5 teeth, 6 additional teeth for front scarifier	1521 lb (690 kg)

Dozer blade float electrovalve

Rear implement

Ripper medium 3 teeth 5 scarifier
Rear pull hook
Machine lifting bracket

Blade

Blade	13' x 2' 2" x 0.86" (3962 x 671 x 22 mm)
Blade	14' x 2' 2" x 0.86" (4267 x 671 x 22 mm)
Right blade extension	2' (610 mm)
Left blade extension	2' (610 mm)

Heavy Duty cutting edge Additional

Work lights

2 work lights behind the blade
2 service lights in front of the moldboard
2 rear implement work lights

Lock/Floating/Anti-shock –

Moldboard and circle

Moldboard lifting cylinder lock valve
Moldboard float electrovalve (incorporates lock valve)
Anti-shock electrovalve with 2 accumulators for moldboard
Anti-shock electrovalve with 3 accumulators for moldboard and circle

Seat/Safety belt

Vinyl seat with mechanical suspension
Cloth seat with air suspension
Seat belt 3" (76,5 mm)

Other optional items

Beacon light
Luxury tool box
Toolbox without tools with support, fixed on front chassis
Slow moving vehicle sign
Electric pump to inflate tires
Spare tire bracket
Axles
Conventional differential with four-wheel brake and differential lock with activation electrohydraulic (rear axle)

Tires and rims mounted

Tubeless tires
10" rim – 3-piece / 14x24 tyre – 12L – G2
13" rim – one-piece / 17.5x25 tyre – 12L – L2
14" rim – 3-piece / 17.5x25 tyre – 12L – L2
14" rim – 3-piece / 17.5x25 tyre – 16L – L3

Tube tires

9" rim – one-piece / 14x24 tyre – 12L – G2
10" rim – 3-piece / 14x24 tyre – 12L – G2

Tubeless radial tires

9" rim – single-piece / 14x24 tyre – 12L – L2
RADIAL XGLA2
10" rim – 3-piece / 14x24 tyre – 12L – L2
RADIAL XGLA2

Rims

9" rim – one-piece with valve
10" rim – 3-piece with valve
13" rim – one-piece with valve
14" rim – 3-piece with valve



SiteWatch™

Fleet monitoring and tracking management system through satellite or mobile phone

Case reserves the right to implement improvements in the project and alterations to the specifications at any time, without prior notice, and not being liable to install them in previously sold units. The specifications, descriptions and graphics correctly reflect the information known to this day in this publication. This information may vary in different regions and may be subject to changes without previous notice. The graphics may include equipment and optional accessories, and may not include all the standard units.

CCEIO133 – 05/2022 – Printed in Brazil

CaseCE.com



Commercial Offices

ARGENTINA

Ávalos 2829 Edif. 1 Piso 4º,
Complejo Urbana
Vicente López (1605) Bs. As., Argentina.
Tel: 54 (11) 2034 1400

Factories

BRAZIL

Contagem – Minas Gerais – Brazil	Sorocaba – São Paulo – Brazil
Av. General David Sarnoff, 2.237	Av. Jerome Case, 1.801
Inconfidentes – C.P. 32210-900	Éden – C.P. 18087-220
Tel.: +55 31 2104-3392	Tel.: +55 15 3334-1700