

865B SERIES 2

ENGINE

Brand	FPT
Model	F4HE9687C*J109
Type	Electronic, diesel, 4-stroke, direct injection, turbocharged, Tier 3 certified
Cylinders	6
Bore and stroke	4.09 x 5.19 in (104 x 132 mm)
Cylinder volume	408.86 in ³ (6,7 l)
Power @ 2200 rpm	
Gross (SAE J1995)	193/205/220 hp (144/153/164 kW)
Net (SAE J1349)	178/190/205 hp (133/142/153 kW)
Maximum torque @ 1500 rpm	
Gross (SAE J1995)	612/649/685 lbf.ft (830/880/930 Nm)
Net (SAE J1349)	548/581/613 lbf.ft (743/788/832 Nm)

POWER TRAIN

Rear axle	
Ground clearance	1 ft 3 in (380 mm)
Differential	Conventional planetary with electro-hydraulic lock 100%, operator driven
*Brakes	Disk, in oil bath
Number of disks per brake	5
Tandem	
Type	Welded panel
	7' 2.7" x 2' 0.8" x 8" (2204 x 631 x 201 mm)
Oscillation	20° in each direction
Command chain pitch	2 in (50,8 mm)
Thickness of inner and external side wall	0.75 in (19 mm)
Front axle	
Type	Welded high resistance steel
Oscillation	15° in each direction
Wheel lean	20° in each direction
Ground clearance	1 ft 11 in (580 mm)

Tyres	17,5 X 25 12 PLY RATE - L2 tubeless
Rims	14" (3 piece)
*SAE J150 3450 (brake performance)	

ELECTRICAL SYSTEM

Voltage	24 V (with grounding)
Alternator	90 A
Batteries	2x100 Ah – low maintenance
Lights	
	Front headlight with turn signals (2)
	Brake light and rear turn signals (2)
	Rear cab mounted work light (2)
	Front cab mounted work light (2)
Monitoring of electronic systems	

HYDRAULIC SYSTEM

Type	Closed centre, load-sensing
Hydraulic pump	Axial piston pump, variable flow, equipped with load sensing system
Nominal flow @ 2200 rpm	49 gpm (186 l/min)
Control valve	9 sections
Diagnostic quick couplers	8

TRANSMISSION

Brand	ZF	
Model	ZF TC LOCK UP 6WG – 160	
Type	Torque converter with lock up (also working as Direct Drive) Powershift, electronic gear shift control, automatic, no inching pedal for progressive advance	
Rated flow @ 2.000 rpm	22.4 gpm (85 l/min)	
Crankcase	Integral	
Drive gears	6 forward / 3 reverse	
Travel control	Automatic electronic control, single "pulsing" lever and automatic module	
Fault diagnostics system	On-board	
Speeds – mph (km/h)		
	Forward	Reverse
1st	3.2 (5,2)	3.41 (5,5)
2nd	5.03 (8,1)	8.13 (13,1)
3rd	7.70 (12,4)	18.82 (30,3)
4th	11.93 (19,2)	-
5th	18.83 (28,7)	-
6th	27.40 (44,1)	-

STEERING

Type	Hydraulic steering
Angle - right and left	42°
Steering wheel turns (lock-to-lock)	4,5
Pump capacity @ 2.200 rpm	11 gpm (41,8 l/min)
Pressure relief	2530 psi (175 bar) built into the steering priority valve
Cylinders	2
Diameter	2 in (50,8 mm)
Stroke	11.8 in (301 mm)
Rod diameter	1 in (25,4 mm)
Supplemental steering	Built-in
SAE J53 and J1511	

ARTICULATION

Type	Hydraulically driven (with lock out system)
Range	25° left/right
Controls	Hydraulic

DRAWBAR

Type	"A" frame welded construction with centre mounted circle turn motor
Connection with the chassis	Shim adjustable ball stud

CIRCLE

Type	Welded construction
Maximum outside diameter	5 ft 9 in (1752,6 mm)
Rotation	360°
Speed	1,2 rpm (7,2°/second)
Power drive	Hydraulic motor
Type	Gearmotor
Nominal hydraulic flow	25 gpm (95 l/min)

CAPACITIES

Engine	4 gal (15 l)
with filter change	4.2 gal (16 l)
Fuel	95 gal (360 l)
Transmission	6.6 gal (25 l)
with filter change	6.9 gal (26 l)
Engine water cooling system	8.5 gal (32 l)
Hydraulic oil reservoir	23.8 gal (90 l)
Total hydraulic system	39.10 gal (148 l)
Circle gearbox	2.95 qt (2,8 l)
Tandem case (each)	18.2 gal (69 l)

MISCELLANEOUS

Front counterweight	With no front implement and with rear ripper
Sadle	5 positions

MOLDBOARD

Type	High-carbon steel
Shape	Involute curve
Width	13 ft (3962 mm)
Height (curved profile)	2 ft 2 in (671 mm)
Thickness	0.86 in (22 mm)
Cutting edge	2, Interchangeable
Blade pitch positions	
Normal pitch	47°
Minimum pitch	42°
Maximum pitch	87°
Blade shift	
Right	2 ft 3 in (686 mm)
Left	1 ft 9 in (533 mm)
Maximum bank cutting angle	
Rear (left and right)	90°
Ground penetration (max.)	2 ft 4 in (711,2 mm)
Lift above the ground (max.)	1 ft 5.5 in (444,5 mm)
Blade side shift and pitch	Hydraulic type

SCARIFIER

Type	Mounted on the front
Cutting width	3 ft 10 in (1168 mm)
Teeth	5 (optional, 11)
Spacing between teeth	9 in (229 mm) 4.5 in (114 mm, optional)
Lift above ground	1 ft 8 in (527 mm)
Maximum penetration	1 ft 0.5 in (318 mm)
Weight	1256 lb (570 kg)

OPERATING WEIGHT

With a blade of 13 ft (3962 mm), full tank, cab, headlights, STD batteries, 17,5 X 25 12PR - L2, light ripper and front counterweight.

	37.338 lb (16.936 kg)
Weight, front axle	10.218 lb (4.635 kg)
Weight, rear axle	27.119 lb (12.301 kg)
Blade pull force	24.457 lb (11.093 kg)
Blade penetration force	17.377 lb (7.882 kg)
Ripper penetration force	19.316 lb (8.762 kg)

REAR RIPPER

Type	Parallelogram
Cutting width	7 ft 2 in (2.195 mm)
Ripper teeth	3 large + 5 small
Optional teeth	+ 2 large + 4 small
Lift above ground	
Large teeth	1 ft 8 in (518 mm)
Small teeth	2 ft 4 in (703 mm)
Maximum penetration	
Large teeth	1 ft 5 in (437 mm)
Small teeth	9.9 in (252 mm)
Weight	1753 lb (795 kg)

FRONT BLADE

Type	Front mounted
Width	9 ft 0.7 in (2762 mm)
Height	3 ft 1.5 in (953 mm)
Lift above ground	2 ft 0.4 in (622 mm)
Penetration	6.5 in (165 mm)
Weight	2568 lb (1165 kg)

DIMENSIONS

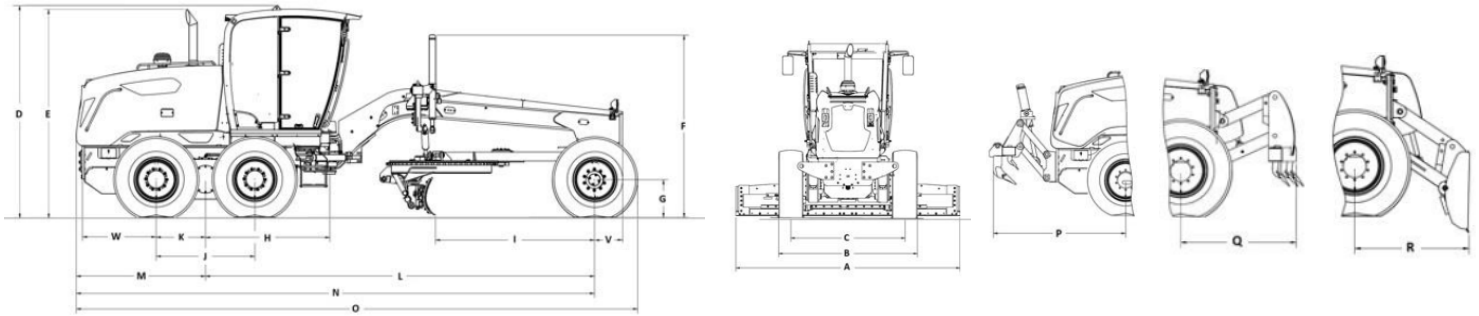

A – Blade width	13' (3.962 mm)
B – Distance between wheels measured at outside of tyres (Total width for transport)	8' 8" (2.663 mm)
C – Distance between the wheels	7' 1" (2.168 mm)
D – Height to top of cab High profile cab Low profile cab	11' 1.8" (3.400 mm) 10' 6" (3.200 mm)
E – Height to top of engine exhaust pipe	10' 10.8" (3.323 mm)
F – Height to top of the blade lift cylinder	10' (3.047 mm)
G – Static tyre radius	2' (610 mm)
H – Distance from centre of tandem to chassis pivot pin	6' 5" (1.958 mm)
I – Distance between front axle and blade	8' 5.0" (2.562 mm)
J – Distance between centre of rear tyres	5' 1.9" (1.572 mm)
K – Distance between centre of tandem and wheel	2' 6.9" (786 mm)
L – Wheelbase	20' 5" (6.219 mm)
M – Distance between centre of tandem and rear section of the equipment	6' 9.3" (2.064 mm)
N – Distance between the front wheel axle and the rear of the equipment	27' 2" (8.283 mm)
O – Total length	29' 4.6" (8.957 mm)
P – Distance between rear tyres and ripper	7' 5.5" (2.273 mm)
Q – Distance between front tyres and front scarifier	5' (1.520 mm)
R – Distance between front tyres and front blade	5' 4" (1.626 mm)
Turning radius (outside the tyres) Turning to the Right Side Turning to the Left Side	24' 7.3" (7.500 mm) 25' 3.1" (7.700 mm)

All units equipped with 17,5 X 25 12PR - L2 tyres, ROPS/FOPS cab, standard battery, full fuel tank, operator weighing 165 lb (75 kg), specifications per ISO 7134.

STANDARD EQUIPMENT

Operator Cab

ROPS/FOPS high closed cab (fixed front window) with:

- Air conditioning (*)
- Adjustable cloth mechanical suspension seat with 2" (50.8 mm) seat belt
- Adjustable operator console
- Pedal accelerator
- Manual accelerator
- Front upper windshield wiper with washer
- Safety glass
- Dome light
- Internal and external rearview mirrors
- 12 V socket (*)
- Automatic master switch
- Steps on the right-hand and left-hand sides

(*) Only available in closed cabs

All ROPS/FOPS cabs are certified according to standards SAE J1040 (ROPS) and SAE J231 (FOPS).

Engine

FPT 6.7 l turbocharged, diesel, Tier 3 certified

- Electronic fuel injection
- Dry air filter with primary and secondary safety elements
- Air pre-filter with cyclonic dust ejector
- 90 A alternator
- 10,5 hp (7,8 kW) starter motor
- Swing-up hood with electric opening and closing

Hydraulic System

Closed centre, load-sensing hydraulic system

- 9-section control valve
- Hydraulic control for all functions:
 - blade lifting (right and left side), circle turn, circle side shift, wheel lean, chassis articulation, blade side shift and pitch, front and rear accessories
- Diagnostic centre with 8 quick couplers
- Movable saddle with 5 service positions and electro-hydraulic lock
- Blade 13' x 2' 2" x 0.86" (3962 x 671 x 22 mm)
- Hydraulic axial piston pump
- Hydraulic motor fan

Brakes

Multi-disk oil-bathed service brakes applied on four rear wheels, with two parallel circuits: one for right tandem wheels and another for left tandem wheels. With nitrogen accumulator safety system. Dry disc parking brakes, applied by spring and hydraulic release.

Tyres

14" Rim 3 pieces / 17,5 x 25 - 12PR - L2
Tubeless

Other

Standard tool set
Drawbar / Standard circle

Axles

Conventional differential with four-wheel brake and differential lock with activation electro-hydraulic (rear axle)

Steering

Hydraulic steering with built-in emergency system

Instruments

Electronic Information Centre

Indicators/gauges:

- Speedometer
- Tachometer
- F/N/R direction selected
- Transmission modes – automatic/manual
- Selected Gear
- Engine coolant temperature
- Fuel level
- Transmission oil temperature
- Hydraulic oil temperature
- Hour meter
- Fuel consumption
- Engine diagnostics
- DeClutch activation indicator
- Transmission diagnostics

Indicator lights

- Low fuel level
- Flood lights
- High Beam
- Brake pressure
- Main alert
- Parking brake

Audible alerts

- Caution alert
- Emergency alert
- Back up alarm

Electrical System

Lights

- Front headlight with turn signal (2)
- Brake light and rear turn signals (2)
- Rear cab mounted work light (2)
- Front cab mounted work light (2)

24 V system (2 12 V / 1010 CCA batteries)

- Electronic systems monitoring
- Hooter
- Hour meter
- Back up alarm

Transmission

ZF Transmission, torque converter type with lock up (also functions as Direct Drive), Powershift, 6 forward and 3 reverse speeds, automatic gear shifting, emergency device in case of electrical failure (Limp-Home).

Rear Implement

Ripper with 3 large teeth and 5 small teeth
1753 lb (795 kg)

Front Implement

Front counterweight 1.146 lb (520 kg)



Conformities ISO
Standards SAE

Cab ROPS	SAE J1040
Cab FOPS	SAE J231
Power	
Gross	SAE J1995
Net	SAE J1349
Torque	
Gross	SAE J1995
Net	SAE J1349
Brakes	SAE J150/ISO-3450
Parking Brake	ISO-3450
Steering	SAE J53 / J1511
Additional steering	SAE 1011 / ISO-5010
Turning radius	ISO-7457
Hydraulic motor turning radius	SAE J499
Engine	
External noise	SAE 1372 / ISO-6393
Cab	
Internal noise	SAE J919

OPTIONAL EQUIPMENT

Cabine (ROPS/FOPS)

Open cab
Closed high cab (front flip-down window)
Closed low cab (fixed front window)
Closed low cab (front flip-down window)

Other

Heater and fan for closed cab
Acoustic insulation for closed cab
Fire extinguisher
Windshield washer and lower windshield wipers
Rear windshield washer and wipers
Radio
Tandem locking device
Sun visor (front and rear)
Rear defroster

Front implement

Dozer blade	2568 lb (1165 kg)
Light push plate	1084 lb (492 kg)
Heavy push plate	1763 lb (800 kg)
Front scarifier with 5 teeth, 6 additional teeth for front scarifier	1521 lb (690 kg)

Dozer blade float electrovalve

Rear implement

Additional teeth for ripper 2 large and 4 small
Rear pull hook
Machine lifting bracket

Blade

Blade	12' x 2' x 0.86" (3658 x 622 x 22 mm)
Blade	14' x 2' 2" x 0.86" (4267 x 671 x 22 mm)
Right blade extension	2' (610 mm)
Left blade extension	2' (610 mm)

Heavy Duty cutting edge Additional

Work lights

2 work lights behind the blade
2 service lights in front of the moldboard
2 rear implement work lights

Lock/Floating/Anti-shock –

Moldboard and circle

Moldboard lifting cylinder lock valve
Moldboard float electrovalve
(incorporates lock valve)
Anti-shock electrovalve
with 2 accumulators for moldboard
Anti-shock electrovalve
with 3 accumulators for moldboard and circle

Seat/Safety belt

Cloth seat with mechanical suspension
Cloth seat with pneumatic suspension
Seat belt 3" (76,5 mm)

Other optional items

Beacon light
Luxury tool box
Toolbox without tools with support, fixed on front chassis
Slow moving vehicle sign
Electric pump to inflate tires
Spare tire bracket

Tires and rims mounted

Tubeless tires

10" rim – 3-piece / 14x24 tyre – 12PR – G2
13" rim – one-piece / 17.5x25 tyre – 12PR – L2
14" rim – 3-piece / 17.5x25 tyre – 12PR – L2
14" rim – 3-piece / 17.5x25 tyre – 16PR – L3

Tube tires

9" rim – one-piece / 14x24 tyre – 12PR – G2
10" rim – 3-piece / 14x24 tyre – 12PR – G2

Tubeless radial tires

9" rim – single-piece / 14x24 tyre – L2
RADIAL XGLA2
10" rim – 3-piece / 14x24 tyre – L2
RADIAL XGLA2
13" rim – single-piece / 17.5x25 tyre – XTLA
14" rim – 3-piece / 17.5x25 tyre – XTLA

Rims

9" rim – one-piece with valve
10" rim – 3-piece with valve
13" rim – one-piece with valve
14" rim – 3-piece with valve



Fleet monitoring and tracking management system through satellite or mobile phone

Case reserves the right to implement improvements in the project and alterations to the specifications at any time, without prior notice, and not being liable to install them in previously sold units. The specifications, descriptions and graphics correctly reflect the information known to this day in this publication. This information may vary in different regions and may be subject to changes without previous notice. The graphics may include equipment and optional accessories, and may not include all the standard units.

CCEIO134 – 05/2022 – Printed in Brazil

CaseCE.com



Commercial Offices

ARGENTINA

Ávalos 2829 Edif. 1 Piso 4º,
Complejo Urbana
Vicente López (1605) Bs. As., Argentina.
Tel: 54 (11) 2034 1400

Factories

BRAZIL

Contagem – Minas Gerais – Brazil
Av. General David Sarnoff, 2.237
Inconfidentes – C.P. 32210-900
Tel.: +55 31 2104-3392

Sorocaba – São Paulo – Brazil
Av. Jerome Case, 1.801
Éden – C.P. 18087-220
Tel.: +55 15 3334-1700