

SKID STEER LOADER

CASE

CONSTRUCTION

SINCE 1842.

SR175B

ENGINE

Brand	Perkins
Model	404D-22T
Type	4 strokes, turbocharged with Tier 3 certification
Cylinders	4
Bore x Stroke	84 x 100 mm (3.31 x 3.94")
Displacement	2,216 cm ³ (135 in ³)
Fuel injection	Indirect
Fuel	Diesel
Fuel filter	In-line filter
Air inlet	Turbocharged with internal EGR
Cooling system	Liquid
Speed (rpm)	
High - no load	3,140 ± 40
Rated - full load	2,900
Low - no load	1,200 ± 30
Power at 2,900 rpm	
Gross SAE J1349	60 hp (44.7 kW)
Net SAE J1349	57 hp (42.4 kW)
Maximum torque at 1,800 rpm	171 N.m (126 lbf.ft)

ENGINE COOLING SYSTEM

Radiator	
Core type	Fully aluminum
Core area	0.26 m ²
Row of tubes	43
Pressure on the lid	1.1 ± 0.1 bar (16 ± 2 psi)
Fan	
Diameter	440 mm (17.3")
Ratio	1.1:1
Water pump	
Type	Centrifuge
Flow	71.2 l/min (18.8 gpm)
Engine lubrication	
Pump Operational Angles	
Side by side	35°
Raised bucket	35°
Lowered bucket	35°
Oil filtration	Full flow cartridge, disposable

POWERTRAIN

Drive Pump - Mechanical	
Pump / motor ratio	1:1
Displacement	35 cm ³ (2.14 in ³)
Pump flow rate with motor at rated rotation of	98 l/min (25.9 gpm)
Charging pressure	24.5 ± 0.5 (360 ± 10)
System relief pressure	345 + 17.3/-0 (5000 + 250/-0)
Control	Mechanical
Drive pump - Electrohydraulic (EH)	
Pump / motor ratio	1:1
Displacement	35 cm ³ (2.14 in ³)
Pump flow rate with motor at rated rotation of	95 l/min (25.1 gpm)
Charging pressure	24.5 ± 1 (362 ± 15)
System relief pressure	360 ± 10 (5220 ± 145)
Control	Electrohydraulic
Traction engines	Fixed displacement with radial pistons
Maximum displacement	325 cm ³ (19.83 in ³)
Speed at rated motor rotation	313 rpm
High speed - optional	443 rpm
Torque at full flow and relief pressure	1783 Nm (1315 lbf pie)
Displacement speed	(tire 10 x 16.5)
Low	12.7 km/h
High (optional)	18.0 km/h
Final reduction	Chain drive with single reduction
Drive chain	
Size	ASA #80
Tensile strength	93.4 kN (21,000 lbf)

Axles

Maximum torque at full flow and relief pressure	5,940 N.m (4,381 lbf.ft)
Diameter	50,8 mm (2")
Length	384 mm (15.12")

Parking break

Type	Spring applied, hydraulic disc release
------	--

Actuation Application of the parking brakes by actuating the brake knob on the hand control or on the instrument panel, by raising the safety bar of the operator's seat, when the operator rises from the seat or by switching off the engine

HYDRAULIC SYSTEM

Standard pump	
Type	Gear pump
Displacement	
Standard	24.9 cm ³ (1.52 in ³)
Optional High Flow	12.5 cm ³ (0.76 in ³)
Pump flow at rated motor rotation	72 l/min (19 gpm)
Flow rate with optional High Flow at rated motor rotation	109 l/min (28.7 gpm)
Skid Steer control valve	
3 spools / Open Center / In-line	
Relief pressure	210 bar (3,046 psi)
Relief pressures	
Arm lift	225 bar (3,263 psi)
Bucket discharge	260 bar (3,770 psi)
Bucket retraction	80 bar (1,160 psi)
Hydraulic oil cooler	
Flaps numbers	3.94 per centimeter
Number of tubes	9
Area	887 cm ² (137.5 in ²)

INSTRUMENT PANEL

Indicators

Text indicators Hour meter, engine rotation, engine cooling fluid temperature, or hydraulic oil temperature
 LCD bar chart for hydraulic oil temperature, engine cooler temperature, and fuel level in fuel tank

Warning lights with alarms

Immediate stop
 Motor malfunction
 Hydraulic system malfunction
 Malfunction of the electronic system

Indicator lights

Warning to lower the security bar
 Parking brake indicator activated
 Engine preheating light

ELECTRIC SYSTEM

Alternator	120 A
Starting motor	2.0 kW
Battery	12 V
950 CCA for cold cranking at -18 °C (0 °F)	

OPERATOR ENVIRONMENT

ROPS / FOPS cab with side screens

Tilting ROPS / FOPS frame

Rear window with emergency exit

Instrument panel

Retractable seat belt

Manual and foot throttle

Alarm package

Cabin roof lining

Solar roof

Cup holder

Power outlet

Foot rest

Storage tray

Ergonomic low effort manual controls

Padded safety bar with integrated armrest

Loader controls locking system

Electric parking brake control

Rubber mat for floor protection / cleaning

CYLINDERS

Lift cylinder

Cylinder diameter	57.2 mm (2.25")
Stem diameter	38.1 mm (1.5")
Stroke	804.9 mm (2' 7.7")
Closed length	1,158 mm (3' 9.6")

Bucket cylinders

Cylinder diameter	69.9 mm (2.75")
Stem diameter	34.9 mm (1.37")
Stroke	410 mm (1' 4.14")
Closed length	610 mm (2')

OPERATIONAL WEIGHTS

Operational weight	2,842 kg (6.270 lb)
Transport weight	2,705 kg (5.970 lb)
Cab side windows	21.3 kg (47 lb)
Lexan® Door	34 kg (75 lb)
Glass door with windshield wiper	34 kg (75 lb)
Suspension seat	10 kg (22 lb)

SERVICE CAPACITIES

Fuel tank	75.7 l (20 gal)
Engine oil (with filter)	7.1 l (1 gal 3.5 ct)
Hydraulic system	
Storage	20 l (5 gal 1.13 ct)
Storage for chains (on each side)	7.4 l (1 gal 3.82 ct)

TIRE SELECTION

	Size	Overall width
Galaxy XD 2002 (10x16.5 Heavy Duty (64 OTW))	10x16.5	1625 mm (64")
TWEEL All Terrain (10X16.5 TWEEL 64 OTW)	10x16.5	1625 mm (64")
Galaxy XD 2002 (12x16.5 Heavy Duty (70 OTW))	12x16.5	1778 mm (70")

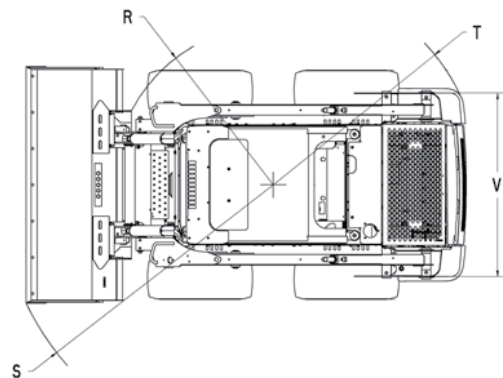
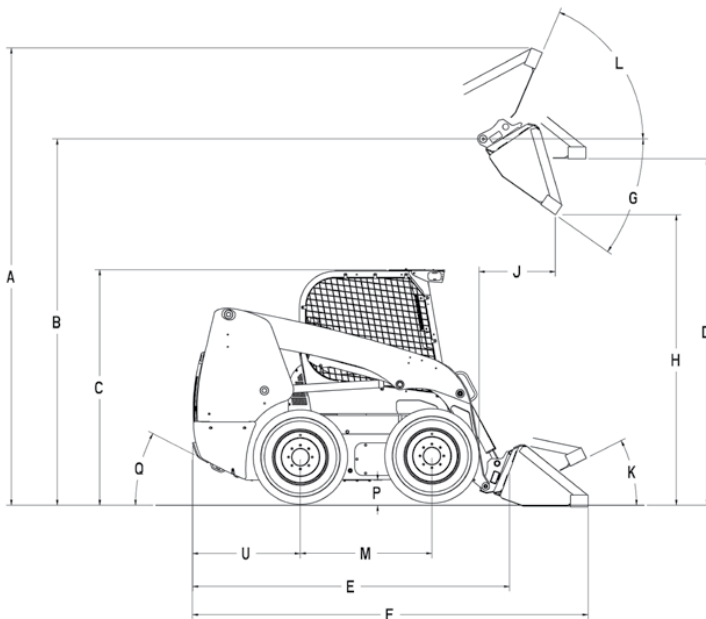

DIMENSIONS

A. Total operational height:	
With foundry / excavation bucket	3.90 m (12' 9.5")
With low profile extended bucket	4.12 m (13' 6.2")
Height up to:	
B. Bucket hinge pin	3.1 m (10' 2")
C. Cabin top	1.97 m (6' 5.6")
D. Leveled bucket bottom with fully raised loader arm	2.93 m (9' 7.3")
Total length:	
E. Without accessories, with coupling device	2.69 m (8' 9.9")
F. With foundry / excavation bucket at ground level	3.31 m (10' 10.3")
With low-profile extended bucket at ground level	3.54 m (11' 7.4")
G. Dump angle at maximum height	39.6°
H. Dump height - fully raised loader arm	
With foundry / excavation bucket	2.47 m (8' 1.2")
With low profile extended bucket	2.40 m (7' 10.5")
J. Reach - fully raised loader arm	0.72 m (2' 4.3")
Attachment maximum retraction angle:	
K. Bucket at ground level	31.6°
L. Bucket at maximum height	98.6°
M. Wheelbase	1.13 m (3' 8.5")
P. Ground clearance (bottom of protection plate)	0.18 m (7.1")
Q. Output angle	23°
Front turning radius:	
R. Without the bucket	1.33 m (4' 4.4")
S. With foundry / excavation bucket at ground level	2.02 m (6' 6.7")
With low-profile extended bucket at ground level	2.23 m (7' 3.8")
T. Rear turning radius	1.60 m (5' 3")
U. Rear axle to bumper	0.92 m (3' 0.2")
V. Machine gauge, measure between the wheel centers	1.37 m (4' 5.9")

SPECIFICATIONS

Operational load	790 kg (1,750 lb)
Dump load	1,588 kg (3,500 lb)
Tear force	
Lifting arm	16.9 kN (3,799 lbf)
Bucket	32.3 kN (7,261 lbf)
Cycle times (in seconds)	
To raise arms	3.4
To lower arms	1.9
To unload attachment	2.6
To retract attachment	1.9

OPTIONAL BUCKETS

Type	Width m (in)	Weight kg (lb)	Heaped capacity m ³ (yd ³)
Foundry / excavation	1,83 (72)	190 (419)	0,46 (0,60)
	1,68 (66)	214 (472)	0,45 (0,59)
Extended low profile	1,83 (72)	232 (511)	0,50 (0,65)
	1,98 (78)	245 (540)	0,54 (0,71)
Heavy Duty	1,83 (72)	230 (507)	0,40 (0,52)

STANDARD EQUIPMENT

Operator environment

ROPS / FOPS cab with side screens
Tilting ROPS / FOPS frame
Rear window with emergency exit
Instrument panel
Retractable seat belt
Manual and foot throttle
Alarm package
Cabin roof lining
Solar roof
Cup holder
Power outlet
Foot rest
Storage tray
Ergonomic low effort manual controls
Padded safety bar with integrated armrest
Controls locking system of the loader
Electric parking brake control
Rubber mat for floor protection / cleaning

Loader

Loader arm radial design
Mechanical device of attachment coupling
Lift arm support beam of the loader

Engine

Perkins 404D-22T
Integrated oil cooling system of the engine
Fuel filter with water separator
Dual element air filter,
120 A alternator
12V 950 CCA battery
Glow plug
Overlapped oil heat exchanger and radiator
Spark-arresting silencers

Power train

Hydrostatic four-wheel drive
Servo controls
ASA #80HS Drive chain
SAHR parking disc brakes

Hydraulic system

210 bar hydraulic system (3,046 psi)
72 l/min (19 gpm)
Hydraulic circuit pedal lock
ISO flat face couplers mounted on loader arm
Cancellation of auxiliary functions
Operational blocking system of the loader
Loader lift neutralizer
Loader 3-spool control valve
Oil exchanger for severe applications
Loader arm fluctuation position

Others

Lockable maintenance access hood
Single point daily maintenance
Halogen lights. 2 frontal. 2 lateral. 2 rear
Rear lights
Remote oil drain

OPTIONAL EQUIPMENT

Operator environment

Suspension seat *Deluxe* coated with special fabric, with lumbar support and heating system
Retractable seat belt
Internal mirror
Bluetooth radio
Air conditioning and heating
Door for demolition purposes
Front auxiliary electric control
Front glass door with windshield wiper and washer
Sliding side windows

Loader

Ride Control
Attachment coupling hydraulic device
One-way hydraulic self-leveling (climb)
Electrohydraulic controls (EH)

Hydraulic system

High flow hydraulic system (*High Flow*) of
210 bar (3,046 psi) 109 l/min (28.7 gal)
Crankcase drain pipe fittings

Engine

Engine block heater
Battery disconnect key

Others

2 speed drive
Deluxe Dashboard
Headlights for highway traffic
Giroflex
Lifting hooks
Special paint
Stickers
Factory installed tires – refer to page 2
Buckets – refer to page 3
Bolt-on bucket cutting blades
Forks to 1.22 m (48")
Additional counterweights



Fleet management and monitoring system by satellite or cell phone tracking.

CASE Corporation reserves the right to make design improvements or feature changes at any time without obligation to install them on previously sold units. Features, descriptions, and illustrative materials included in this document, accurately reflect known data until the date of publication, although they are subject to changes without notice. Illustrations may include optional equipment and accessories and may not include all standard equipment.

CCEIO150 - 12/2022 - Printed in Brazil

CaseCE.com



Manufacturing plants

Contagem – Minas Gerais – Brazil
Av. General David Sarnoff, 2237
Inconfidentes – C. P. 32210-900
Phone.: +55 31 2104-3392

Sorocaba – São Paulo – Brasil
Av. Jerome Case, 1801
Éden – C. P. 18087-220
Phone: +55 15 3334-1700