

WHEEL LOADER

CASE

CONSTRUCTION

SINCE 1842.

621G

ENGINE

Make	FPT
Model	F4HFE613W
Emissions Certification	Tier 4 Final
Emissions Technology	SCR/DOC
Type	4-stroke, turbocharged and air-to-air cooled
Cylinders	6-cylinder in-line
Bore/Stroke	4.09 x 5.20 in (104 x 132 mm)
Displacement	411 in ³ (6.7 L)
Fuel	#2 Diesel, #1 and #2 mixture permitted for cold temperatures
Fuel injection	Direct injection – electronic
Fuel filter	Replaceable
Fuel pump	Bosch
Gradeability:	
Side-to-side	35°
Fore and aft	35°
Air filter	Dry type elements w/ warning restriction indicator
Mid-mount cooling module:	Mid-mount air/water
Fan – hydraulic driven:	
Style	8 blade puller
Diameter	32 in (813 mm)
Water pump	Integral
Engine oil pump operating angle ratings:	
Side-to-side	35°
Fore and aft	35°
Oil filtration	Replaceable
Engine speeds	RPM
Rated – full load	2000
Horsepower:	
Maximum Power Mode:	
Peak gross @ 1800 RPM	172 hp (128 kW)
Net rated @ 2000 RPM	151 hp (113 kW)
Peak net @ 1800 RPM	162 hp (121 kW)
Torque – peak:	
Maximum Power Mode:	
Gross @ 1600 RPM	538 lb-ft (730 N-m)
Net @ 1600 RPM	510 lb-ft (692 N-m)
Net torque rise:	
Maximum power range	29%
NOTE: Gross horsepower and torque per SAE J1995.	
Net horsepower and torque per SAE J1349.	

DRIVETRAIN

Transmission:	4F/3R Proportional w/ Electronic Control Module torque sensing autoshift/manual shift and modulation
Gears	Helical cut
Gear ratios – 4-speed Forward/Reverse	
1st	4.012/3.804
2nd	2.174/2.061
3rd	1.088/1.031
4th	0.619/ –
Torque converter:	
Stall ratio – 4-speed	2.66:1
Differential:	Limited slip with 34% of available axle torque to wheel w/ traction
Rear axle oscillation	24° total
Front and rear axles:	
Differential ratio	3.18
Planetary ratio	6.40
Final axle ratio	20.34
Heavy-duty axles – optional:	
Front axle equipped w/ locking differential	
Rear axle equipped w/ open differential	
Planetaries	Outboard
Service brakes:	Hydraulically actuated, maintenance-free, multiple wet disc w/ accumulator to all four wheels
Brake surface area:	
Front hub – each	480 in ² (0.31 m ²)
Rear hub – each	480 in ² (0.31 m ²)
Parking brakes:	Spring-applied hydraulic release disc on transmission output shaft neutralizes power flow to wheels when engaged
Travel speeds – 4-speed transmission:	
	Forward Reverse
	mph (kph) mph (kph)
1st	4.3 (6.9) 4.5 (7.3)
2nd	8.4 (13.5) 8.8 (14.2)
3rd	14.9 (23.9) 15.6 (25.0)
4th	24.0 (38.6) –
NOTE: Travel speeds at full engine throttle w/ 20.5-R25 (L3 Radial) tires.	

ELECTRICAL

Voltage	24 Volts, negative ground
Alternator	120 amp
Batteries (2)	12-volt

OPERATOR ENVIRONMENT

ROPS cab AC w/ heat; 8" LCD touchscreen display, adjustable armrest w/ 3 configurable buttons; Key start; Articulated power steering w/ tilt column; Fully adjustable, suspension seat w/ headrest; Foot throttle; Single lever (joystick) loader control w/ auxiliary function and fully adjustable wrist rest, 2 cup holders; Interior rear view mirror; 3 inch (76 mm) retractable seat belt; Integrated 4-corner strobe; Multiple storage trays; Single brake pedal; F/N/R shuttle switch; Left and Right external side mirrors; Pressurized air filtering; Anti-glare window strip; Front and Rear Defroster; Side window, partial/fully open; 2 Dome lights; Wipers, rear and intermittent front; Windshield washers, front and rear; Rubber floor mat; Horn; Radio ready – Includes antenna, speakers, wiring, radio fuse, 20A converter, 12-volt auxiliary power outlet, and USB outlet

Displays/Gauges:

Digital:

- Transmission oil temperature; Engine coolant temperature; Fuel level; DEF level.

LCD screen:

- Hour meter; Engine speed; Travel speed; Time; Automatic transmission indication; Current gear selection; FNR indication; DeClutch indication; Engine mode indication; Trip computer A/B; Fuel consumption; Multiple languages, Metric/English; Engine diagnostics; Transmission diagnostics; Warning prompts; Error reporting; DEF gauge; Diff. lock*.

Audible/Visual alarms:

Warning lights:

- Four-way flashers and turn signals; Brake pressure; Lamp/high beam indication; Engine block heater.

Caution warnings:

- Parking brake; Coolant temperature; Hydraulic oil temperature; Transmission oil temperature; Air filter; Transmission filter; Hydraulic filter; Alternator; Low fuel.

Critical warnings:

Engine oil pressure; Brake pressure; Steering pressure – w/ aux. steering*; Coolant temperature; Hydraulic oil temperature; Transmission oil temperature.

Backup alarm

Maintenance reminders:

Cab air filter; Engine oil filter; Fuel pre-filter; DEF tank vent filter; SCR supply filter; Hydraulic oil and filter; Engine air filter; Engine coolant drive belt; Cab recirculation filter; Engine breather filter; Transmission breather; Front and rear axle fluid; SCR supply module filter.

NOTE: *If equipped w/ option.

OPERATING WEIGHT

Z-Bar

Unit equipped w/ 2.75 yd³ (2.1 m³) Case pin on bucket w/ edge; 20.5-R25 L3 Radial tires; ROPS cab w/ heater and A/C; Std. battery; Heavy counterweight – 1,950 lb (885 kg); Front and rear fenders; Lights; 165 lb (75 kg) operator: 28,159 lb (12 773 kg)

XT

Unit equipped w/ 2.5 yd³ (1.9 m³) CNH w/ edge and JRB coupler; 20.5-R25 L3 Radial tires; ROPS cab w/ heater and A/C; Std. battery; Heavy counterweight – 1,950 lb (885 kg); Front and rear fenders; Lights; 165 lb (75 kg) operator: 29,076 lb (13 188 kg)

HYDRAULICS

Pump – steering/implement: Closed center pressure/flow compensated Variable displacement – load-sensing: 45.2 gpm @ 2000 RPM (171 L/min @ 2000 RPM)

Loader control valve: Closed-center, sectional 2, 3 or 4-function w/ control for lift, tilt and auxiliary hydraulics

Loader auxiliary steering: Hydraulic orbital center-pivot articulating w/ on-demand oil flow

High pressure standby: Implement 3,625 psi (25 000 kPa) Steering 3,500 psi (24 132 kPa)

Filtration: Filtered vent w/ relief on hydraulic reservoir, maintains 3-5 psi on reservoir, 10-micron, return filter furnishes only clean oil to all components of the system.

SERVICE CAPACITIES

Fuel tank 65.0 gal (246.0 L)

DEF tank – Diesel Exhaust Fluid: Usable capacity 9.8 gal (37.1 L) Total 15.6 gal (58.9 L)

Hydraulic system: Reservoir 24.0 gal (90.8 L) Total 39.0 gal (147.6 L)

Transmission: Service w/ filter 29.2 qt (26.7 L)

Front and rear axle: Front axle 23.2 qt (22.0 L) Rear axle 23.2 qt (22.0 L)

Front and rear axle – optional: Front axle 23.2 qt (22.0 L) Rear axle 23.2 qt (22.0 L)

Engine oil w/ filter 14 qt (13.2 L)

Cooling system 28.4 qt (26.8 L)

OTHER SPECIFICATIONS

Lift cylinder: Bore diameter 4.7 in (120.6 mm) Rod diameter 2.5 in (63.5 mm) Stroke 31.0 in (787.6 mm)

Dump cylinder – Z-Bar: Bore diameter 5.0 in (127 mm) Rod diameter 3.0 in (76.2 mm) Stroke 24.4 in (619.7 mm)

Dump cylinder – XT: Bore diameter 4.5 in (114 mm) Rod diameter 2.5 in (63.5 mm) Stroke 32.6 in (819.9 mm)

Loader: Z-Bar loader linkage; Single control for lift and tilt; Positive hold float; Automatic return-to-dig; Automatic height control; Automatic return-to-travel; Brake pedal transmission disconnect; Bucket position indicator on bucket.

Cycle time: Raise w/ rated bucket load: Z-Bar 6.3 sec XT 6.5 sec

Dump w/ rated bucket load: Z-Bar 1.2 sec XT 2.4 sec

Float down: Z-Bar 4.8 sec XT 4.2 sec

Sound level in Cab (LpA) 68 dB(A)

Exterior sound level (LwA) 104DbA

NOTE: Sound level data tested in accordance with ISO6395, 6396, 3744.

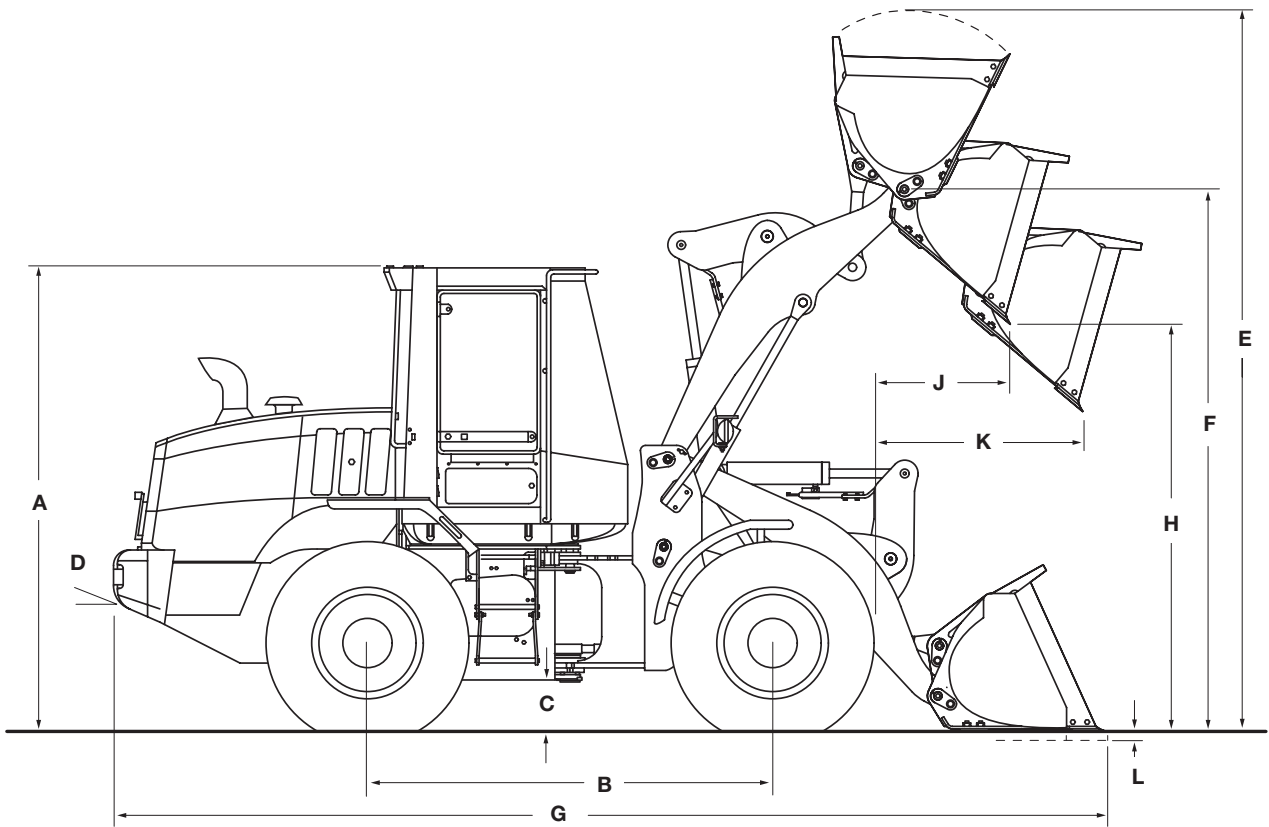

Line drawings are for illustrative purpose only and may not be exact representation of unit.

DIMENSIONS

A. Height to top of ROPS cab	133.2 in (3 384 mm)
Height to drawbar	42.1 in (1 070 mm)
B. Wheelbase	114.2 in (2 900 mm)
C. Ground clearance	15.3 in (389 mm)
D. Angle of departure	25°
Width:	
Overall* without bucket	97.6 in (2 478 mm)
Centerline tread	76.8 in (1 950 mm)
Turning radius* – outside	205.6 in (5 223 mm)
Turning angle:	
From center	40°
Total angle	80°
Rear axle oscillation – total	24°

NOTE: *Dimensions taken with 20.5-R25 (L3 Radial) tires. For transport dimensions, refer to specific bucket width and overall length on pages 4 through 9.

WEIGHT ADJUSTMENTS

Select Options	Weight Adjustment	Tipping Load Adjustment	
		Straight: Deflected*	40° Turn: Deflected*
20.5 x 25 12 ply L2 Bias tires	-592 lb (-269 kg)	-618 lb (-280 kg)	-1,179 lb (-535 kg)
20.5 x 25 12 ply L3 Bias tires	-20 lb (-9 kg)	+240 lb (+109 kg)	+363 lb (+165 kg)
20.5-R25 L2 Radial tires	-256 lb (-116 kg)	-259 lb (-117 kg)	-189 lb (-86 kg)
20.5-R25 Snow Radial Tires	-132 lb (-60 kg)	-175 lb (-79 kg)	-111 lb (-50 kg)
20.5-R25 Solid Tires Req. Diff Axles, Ltd Speed Controller	+4,782 lb (+2 169 kg)	+3,140 lb (+1 424 kg)	+3,327 lb (+1 509 kg)

NOTE: Unit equipped with Z-Bar loader arms, 2.5 yd³ (1.9 m³) general purpose pin on bucket with bolt-on edge, 20.5-R25 (L3 Radial) tires, ROPS cab with heater and air conditioner, heavy counterweight, standard batteries, front and rear fenders, full fuel and 165 lb (79 kg) operator. Adjust select options from rated weight. *Tipping loads: ISO 14397-1 Deflected Tires.

PERFORMANCE SPECS

621G Z-Bar*	3.0 yd ³ (2.3 m ³) Bucket with Bolt-on Edge - Pin On	2.5 yd ³ (1.9 m ³) Bucket with Bolt-on Edge - Pin On	2.4 yd ³ (1.8 m ³) Bucket with Teeth Only - Pin On	4.5 yd ³ (3.4 m ³) Bucket with Bolt-on Edge - Pin On
Operating weight	28,254 lb (12.816 kg)	28,093 lb (12.743 kg)	28,013 lb (12.707 kg)	28,672 lb (13.005 kg)
E. Operating height – fully raised with spillguard	198.6 in (5,044 mm)	194.5 in (4,941 mm)	194.5 in (4,941 mm)	212.9 in (5,408 mm)
F. Hinge pin height – fully raised	150.9 in (3,833 mm)	150.9 in (3,833 mm)	150.9 in (3,834 mm)	150.9 in (3,833 mm)
G. Overall length – bucket level on ground	290.6 in (7,380 mm)	284.9 in (7,237 mm)	290.6 in (7,382 mm)	302.9 in (7,694 mm)
Dump angle – fully raised	51°	51°	51°	50°
H. Dump height – fully raised, 45° dump	110.4 in (2,804 mm)	114.1 in (2,899 mm)	110.4 in (2,805 mm)	102.2 in (2,596 mm)
J. Bucket reach – fully raised, 45° dump	39.8 in (1,010 mm)	36.0 in (916 mm)	40.2 in (1,021 mm)	47.9 in (1,216 mm)
K. Bucket reach – 7 ft 0 in (2.13 m) height, 45° dump	59.6 in (1,513 mm)	57.7 in (1,466 mm)	60.0 in (1,525 mm)	62.9 in (1,598 mm)
L. Dig depth	3.3 in (84 mm)	2.8 in (72 mm)	3.0 in (76 mm)	4.4 in (111 mm)
Operating load – ISO Rigid Tires	10,299 lb (4,671 kg)	10,569 lb (4,794 kg)	10,703 lb (4,855 kg)	9,637 lb (4,371 kg)
Operating load – ISO Deflected Tires	9,375 lb (4,252 kg)	9,633 lb (4,369 kg)	9,756 lb (4,425 kg)	8,737 lb (3,963 kg)
Maximum material density – ISO Rigid Tires	3,433 lb/yd ³ (2.037 kg/m ³)	4,228 lb/yd ³ (2,509 kg/m ³)	4,460 lb/yd ³ (2,646 kg/m ³)	2,142 lb/yd ³ (1,271 kg/m ³)
Maximum material density – ISO Deflected Tires	3,125 lb/yd ³ (1,854 kg/m ³)	3,853 lb/yd ³ (2,286 kg/m ³)	4,065 lb/yd ³ (2,412 kg/m ³)	1,942 lb/yd ³ (1,152 kg/m ³)
Tipping load – ISO Rigid Tires: Straight 40° turn	23,725 lb (10,761 kg) 20,597 lb (9,343 kg)	21,138 lb (9,588 kg) 21,138 lb (9,588 kg)	24,612 lb (11,164 kg) 21,407 lb (9,710 kg)	22,275 lb (10,104 kg) 19,274 lb (8,742 kg)
Tipping load – ISO Deflected Tires: Straight 40° turn	22,307 lb (10,118 kg) 18,749 lb (8,504 kg)	22,881 lb (10,378 kg) 19,266 lb (8,739 kg)	23,155 lb (10,503 kg) 19,511 lb (8,850 kg)	20,896 lb (9,478 kg) 17,474 lb (7,926 kg)
Lift capacity: Full height Ground	16,266 lb (7,378 kg) 22,395 lb (10,158 kg)	16,442 lb (7,458 kg) 25,278 lb (11,466 kg)	16,530 lb (7,498 kg) 26,675 lb (12,100 kg)	15,794 lb (7,164 kg) 21,930 lb (9,947 kg)
Breakout force with tilt cylinder	24,031 lb (10,900 kg)	27,280 lb (12,374 kg)	29,182 lb (13,237 kg)	18,285 lb (8,294 kg)
Loader clearance circle with bucket	455.1 in (11,560 mm)	451.9 in (11,478 mm)	454.8 in (11,552 mm)	462.3 in (11,743 mm)

621G Z-Bar*	Z-Bar	Z-Bar	Z-Bar	Z-Bar
Maximum rollback: Ground	41°/40°	40°/40°	40°/40°	42°/42°
Carry position	45°/45°	45°/45°	45°/45°	45°/47°
@ Full height	55°/59°	55°/59°	55°/59°	55°/59°
Maximum grading angle with bucket – back dragging	59°/59°	58°/58°	59°/59°	64°/63°
SAE bucket capacity – struck	2.56 yd ³ (1.96 m ³)	2.15 yd ³ (1.64 m ³)	2.05 yd ³ (1.57 m ³)	3.71 yd ³ (2.84 m ³)
Heaped	3.00 yd ³ (2.29 m ³)	2.50 yd ³ (1.91 m ³)	2.40 yd ³ (1.83 m ³)	4.50 yd ³ (3.44 m ³)
Tipping load – ISO Deflected Tires: Straight 40° turn	3.00 yd ³ (2.29 m ³)	2.15 yd ³ (1.64 m ³)	23,155 lb (10,503 kg) 19,511 lb (8,850 kg)	20,896 lb (9,478 kg) 17,474 lb (7,926 kg)
Bucket width – outside	102.4 in (2,602 mm)	102.4 in (2,602 mm)	102.1 in (2,593 mm)	102.4 in (2,602 mm)
Bucket weight	1,957 lb (888 kg)	1,796 lb (814 kg)	1,716 lb (778 kg)	2,374 lb (1,077 kg)

PERFORMANCE SPECS

621G Z-Bar*	3.0 yd³ (2.29 m³) Bucket with Bolt-on Edge - JRB Coupler	2.8 yd³ (2.14 m³) Bucket with Teeth - JRB Coupler	2.5 yd³ (1.91 m³) Bucket with Bolt-on Edge - JRB Coupler	2.4 yd³ (1.8 m³) Bucket with Teeth - JRB Coupler
Operating weight	29,119 lb (13,208 kg)	29,039 lb (13,172 kg)	28,930 lb (13,122 kg)	28,852 lb (13,087 kg)
E. Operating height – fully raised with spillguard	205.1 in (5,209 mm)	205.1 in (5,209 mm)	200.4 in (5,090 mm)	200.4 in (5,090 mm)
F. Hinge pin height – fully raised	150.9 in (3,832 mm)	150.9 in (3,832 mm)	150.9 in (3,832 mm)	150.9 in (3,832 mm)
G. Overall length – bucket level on ground	299.2 in (7,601 mm)	305.0 in (7,746 mm)	293.7 in (7,460 mm)	299.4 in (7,604 mm)
Dump angle – fully raised	51°	51°	51°	51°
H. Dump height – fully raised, 45° dump	104.9 in (2,664 mm)	101.2 in (2,570 mm)	108.5 in (2,755 mm)	104.8 in (2,661 mm)
J. Bucket reach – fully raised, 45° dump	47.0 in (1,193 mm)	51.1 in (1,299 mm)	42.7 in (1,085 mm)	46.9 in (1,191 mm)
K. Bucket reach – 7 ft 0 in (2.13 m) height, 45° dump	63.7 in (1,618 mm)	65.5 in (1,664 mm)	61.5 in (1,562 mm)	63.6 in (1,614 mm)
L. Dig depth	2.9 in (73 mm)	3.0 in (77 mm)	2.9 in (73 mm)	3.0 in (77 mm)
Operating load – ISO Rigid Tires	9,271 lb (4,205 kg)	9,398 lb (4,263 kg)	9,500 lb (4,309 kg)	9,619 lb (4,363 kg)
Operating load – ISO Deflected Tires	8,407 lb (3,813 kg)	8,522 lb (3,866 kg)	8,631 lb (3,915 kg)	8,739 lb (3,964 kg)
Maximum material density – ISO Rigid Tires	3,090 lb/yd ³ (1,834 kg/m ³)	3,356 lb/yd ³ (1,992 kg/m ³)	3,800 lb/yd ³ (2,255 kg/m ³)	4,008 lb/yd ³ (2,378 kg/m ³)
Maximum material density – ISO Deflected Tires	2,802 lb/yd ³ (1,663 kg/m ³)	3,044 lb/yd ³ (1,806 kg/m ³)	3,452 lb/yd ³ (2,048 kg/m ³)	3,641 lb/yd ³ (2,161 kg/m ³)
Tipping load – ISO Rigid Tires: Straight 40° turn	21,483 lb (9,744 kg) 18,543 lb (8,411 kg)	21,760 lb (9,870 kg) 18,796 lb (8,526 kg)	21,978 lb (9,969 kg) 18,999 lb (8,618 kg)	22,238 lb (10,087 kg) 19,238 lb (8,726 kg)
Tipping load – ISO Deflected Tires: Straight 40° turn	20,161 lb (9,145 kg) 16,813 lb (7,626 kg)	20,420 lb (9,262 kg) 17,045 lb (7,731 kg)	20,649 lb (9,366 kg) 17,261 lb (7,830 kg)	20,892 lb (9,476 kg) 17,478 lb (7,928 kg)
Lift capacity: Full height Ground	15,397 lb (6,984 kg) 20,923 lb (9,491 kg)	15,452 lb (7,009 kg) 16,177 lb (7,338 kg)	15,564 lb (7,060 kg) 16,975 lb (7,700 kg)	15,649 lb (7,098 kg) 17,704 lb (8,030 kg)
Breakout force with tilt cylinder	18,868 lb (8,558 kg)	20,530 lb (9,312 kg)	21,896 lb (9,932 kg)	23,163 lb (10,506 kg)
Loader clearance circle with bucket	460.2 in (11,689 mm)	463.4 in (11,771 mm)	456.9 in (11,605 mm)	460.0 in (11,683 mm)

621G	Z-Bar	Z-Bar	Z-Bar	Z-Bar
Maximum rollback: Ground	40°/40°	40°/40°	40°/40°	40°/40°
Carry position @ Full height	45°/46° 55°/59°	45°/46° 55°/59°	45°/46° 55°/59°	45°/46° 55°/59°
Maximum grading angle with bucket – back dragging	62°/61°	64°/62°	60°/60°	62°/61°
SAE bucket capacity – struck	2.60 yd ³ (1.99 m ³)	2.40 yd ³ (1.83 m ³)	2.15 yd ³ (1.64 m ³)	2.05 yd ³ (1.57 m ³)
Heaped	3.00 yd ³ (2.29 m ³)	2.80 yd ³ (2.14 m ³)	2.50 yd ³ (1.91 m ³)	2.40 yd ³ (1.83 m ³)
Bucket width – outside	102.4 in (2,602 mm)	102.1 in (2,593 mm)	102.4 in (2,602 mm)	102.1 in (2,593 mm)
Bucket weight	2,821 lb (1,280 kg)	2,741 lb (1,243 kg)	2,632 lb (1,194 kg)	2,554 lb (1,158 kg)

PERFORMANCE SPECS

Z-Bar*	3.0 yd ³ (2.29 m ³) Bucket with Bolt-on Edge - ACS Coupler	2.8 yd ³ (2.14 m ³) Bucket with Teeth - ACS Coupler	2.5 yd ³ (1.91 m ³) Bucket with Bolt-on Edge - ACS Coupler	2.4 yd ³ (1.8 m ³) Bucket with Teeth - ACS Coupler
Operating weight	29,322 lb (13,300 kg)	29,242 lb (13,264 kg)	29,109 lb (13,203 kg)	29,028 lb (13,167 kg)
E. Operating height – fully raised with spillguard	203.7 in (5,173 mm)	203.7 in (5,173 mm)	199.2 in (5,059 mm)	199.2 in (5,059 mm)
F. Hinge pin height – fully raised	150.9 in (3,832 mm)	150.9 in (3,832 mm)	150.9 in (3,832 mm)	150.9 in (3,832 mm)
G. Overall length – bucket level on ground	297.3 in (7,551 mm)	303.0 in (7,696 mm)	292.0 in (7,418 mm)	297.7 in (7,562 mm)
Dump angle – fully raised	51°	51°	51°	51°
H. Dump height – fully raised, 45° dump	106.1 in (2,696 mm)	102.4 in (2,602 mm)	109.5 in (2,782 mm)	105.8 in (2,688 mm)
J. Bucket reach – fully raised, 45° dump	45.5 in (1,155 mm)	49.6 in (1,260 mm)	41.5 in (1,053 mm)	45.6 in (1,158 mm)
K. Bucket reach – 7 ft 0 in (2.13 m) height, 45° dump	62.9 in (1,598 mm)	64.8 in (1,646 mm)	60.8 in (1,545 mm)	62.9 in (1,597 mm)
L. Dig depth	2.9 in (74 mm)	3.1 in (78 mm)	2.9 in (73 mm)	3.1 in (78 mm)
Operating load – ISO Rigid Tires	9,329 lb (4,232 kg)	9,456 lb (4,289 kg)	9,542 lb (4,328 kg)	9,662 lb (4,383 kg)
Operating load – ISO Deflected Tires	8,450 lb (3,833 kg)	8,566 lb (3,886 kg)	8,661 lb (3,928 kg)	8,771 lb (3,978 kg)
Maximum material density – ISO Rigid Tires	3,110 lb/yd ³ (1,845 kg/m ³)	3,377 lb/yd ³ (2,004 kg/m ³)	3,817 lb/yd ³ (2,265 kg/m ³)	4,026 lb/yd ³ (2,389 kg/m ³)
Maximum material density – ISO Deflected Tires	2,817 lb/yd ³ (1,671 kg/m ³)	3,059 lb/yd ³ (1,815 kg/m ³)	3,464 lb/yd ³ (2,056 kg/m ³)	3,655 lb/yd ³ (2,168 kg/m ³)
Tipping load – ISO Rigid Tires: Straight 40° turn	21,642 lb (9,817 kg) 18,658 lb (8,463 kg)	21,921 lb (9,943 kg) 18,913 lb (8,579 kg)	22,099 lb (10,024 kg) 19,084 lb (8,656 kg)	22,361 lb (10,143 kg) 19,324 lb (8,765 kg)
Tipping load – ISO Deflected Tires: Straight 40° turn	20,296 lb (9,206 kg) 16,899 lb (7,665 kg)	20,558 lb (9,325 kg) 17,133 lb (7,771 kg)	20,750 lb (9,412 kg) 17,321 lb (7,857 kg)	20,996 lb (9,524 kg) 17,542 lb (7,957 kg)
Lift capacity: Full height Ground	15,175 lb (6,883 kg) 16,546 lb (7,505 kg)	15,263 lb (6,923 kg) 17,354 lb (7,871 kg)	15,396 lb (6,984 kg) 17,992 lb (8,161 kg)	15,483 lb (7,023 kg) 18,795 lb (8,525 kg)
Breakout force with tilt cylinder	20,212 lb (9,168 kg)	21,315 lb (9,668 kg)	22,635 lb (10,267 kg)	24,003 lb (10,887 kg)
Loader clearance circle with bucket	459.0 in (11,659 mm)	462.2 in (11,740 mm)	455.9 in (11,580 mm)	459.0 in (11,658 mm)

621G	Z-Bar	Z-Bar	Z-Bar	Z-Bar
Maximum rollback: Ground	40°/40°	40°/40°	40°/40°	40°/40°
Carry position @ Full height	45°/46° 55°/59°	45°/46° 55°/59°	45°/46° 55°/59°	45°/46° 55°/59°
Maximum grading angle with bucket – back dragging	61°/60°	63°/61°	60°/60°	61°/60°
SAE bucket capacity – struck Heaped	2.60 yd ³ (1.99 m ³) 3.00 yd ³ (2.29 m ³)	2.40 yd ³ (1.83 m ³) 2.80 yd ³ (2.14 m ³)	2.15 yd ³ (1.64 m ³) 2.50 yd ³ (1.91 m ³)	2.05 yd ³ (1.57 m ³) 2.40 yd ³ (1.83 m ³)
Bucket width – outside	102.4 in (2,602 mm)	102.1 in (2,593 mm)	102.4 in (2,602 mm)	102.1 in (2,593 mm)
Bucket weight	3,024 lb (1,372 kg)	2,944 lb (1,335 kg)	2,811 lb (1,275 kg)	2,731 lb (1,239 kg)

PERFORMANCE SPECS

621G XT	3.0 yd³ (2.29 m³) Bucket with Bolt-on Edge - JRB Coupler	2.8 yd³ (2.14 m³) Bucket with Teeth - JRB Coupler	2.5 yd³ (1.91 m³) Bucket with Bolt-on Edge - JRB Coupler	2.4 yd³ (1.8 m³) Bucket with Teeth - JRB Coupler
Operating weight	29,519 lb (13,389 kg)	29,442 lb (13,355 kg)	29,332 lb (13,305 kg)	29,253 lb (13,269 kg)
E. Operating height – fully raised with spillguard	216.7 in (5,505 mm)	216.7 in (5,505 mm)	212.0 in (5,386 mm)	212.0 in (5,386 mm)
F. Hinge pin height – fully raised	155.9 in (3,960 mm)	155.9 in (3,960 mm)	155.9 in (3,960 mm)	155.9 in (3,960 mm)
G. Overall length – bucket level on ground	307.2 in (7,818 mm)	313.5 in (7,963 mm)	302.2 in (7,676 mm)	307.7 in (7,817 mm)
Dump angle – fully raised	55°	55°	55°	55°
H. Dump height – fully raised, 45° dump	104.3 in (2,648 mm)	100.6 in (2,554 mm)	107.8 in (2,739 mm)	104.3 in (2,648 mm)
J. Bucket reach – fully raised, 45° dump	55.5 in (1,409 mm)	59.6 in (1,515 mm)	51.2 in (1,301 mm)	55.2 in (1,402 mm)
K. Bucket reach – 7 ft 0 in (2.13 m) height, 45° dump	72.2 in (1,833 mm)	73.9 in (1,878 mm)	70.1 in (1,780 mm)	71.9 in (1,827 mm)
L. Dig depth	2.5 in (62 mm)	2.6 in (66 mm)	2.4 in (62 mm)	2.6 in (66 mm)
Operating load – ISO Rigid Tires	8,506 lb (3,858 kg)	8,616 lb (3,908 kg)	8,704 lb (3,948 kg)	8,421 lb (3,820 kg)
Operating load – ISO Deflected Tires	7,672 lb (3,480 kg)	7,774 lb (3,526 kg)	7,867 lb (3,568 kg)	7,617 lb (3,455 kg)
Maximum material density – ISO Rigid Tires	2,835 lb/yd ³ (1,682 kg/m ³)	3,077 lb/yd ³ (1,826 kg/m ³)	3,482 lb/yd ³ (2,066 kg/m ³)	3,509 lb/yd ³ (2,082 kg/m ³)
Maximum material density – ISO Deflected Tires	2,557 lb/yd ³ (1,517 kg/m ³)	2,776 lb/yd ³ (1,647 kg/m ³)	3,147 lb/yd ³ (1,867 kg/m ³)	3,174 lb/yd ³ (1,883 kg/m ³)
Tipping load – ISO Rigid Tires: Straight 40° turn	19,723 lb (8,946 kg) 17,012 lb (7,716 kg)	19,963 lb (9,055 kg) 17,233 lb (7,817 kg)	20,149 lb (9,140 kg) 17,409 lb (7,896 kg)	19,480 lb (8,836 kg) 16,843 lb (7,640 kg)
Tipping load – ISO Deflected Tires: Straight 40° turn	18,456 lb (8,372 kg) 15,344 lb (6,960 kg)	18,683 lb (8,474 kg) 15,548 lb (7,052 kg)	18,877 lb (8,562 kg) 15,733 lb (7,136 kg)	18,262 lb (8,283 kg) 15,235 lb (6,910 kg)
Lift capacity: Full height Ground	13,913 lb (6,311 kg) 26,995 lb (12,245 kg)	14,055 lb (6,375 kg) 28,110 lb (12,750 kg)	14,175 lb (6,430 kg) 28,545 lb (12,948 kg)	13,985 lb (6,344 kg) 24,581 lb (11,150 kg)
Breakout force with tilt cylinder	20,671 lb (9,376 kg)	21,613 lb (9,803 kg)	22,854 lb (10,366 kg)	24,077 lb (10,921 kg)
Loader clearance circle with bucket	453.4 in (11,517 mm)	455.5 in (11,569 mm)	451.2 in (11,460 mm)	453.1 in (11,509 mm)

621G XT	3.0 yd³ (2.29 m³) Bucket with Bolt-on Edge - ACS Coupler	2.8 yd³ (2.14 m³) Bucket with Teeth - ACS Coupler	2.5 yd³ (1.91 m³) Bucket with Bolt-on Edge - ACS Coupler	2.4 yd³ (1.8 m³) Bucket with Teeth - ACS Coupler
Operating weight	29,852 lb (13,541 kg)	29,774 lb (13,505 kg)	29,639 lb (13,444 kg)	29,561 lb (13,409 kg)
E. Operating height – fully raised with spillguard	212.1 in (5,387 mm)	212.1 in (5,387 mm)	207.6 in (5,274 mm)	207.6 in (5,274 mm)
F. Hinge pin height – fully raised	155.9 in (3,959 mm)	155.9 in (3,959 mm)	155.9 in (3,959 mm)	155.9 in (3,959 mm)
G. Overall length – bucket level on ground	301.8 in (7,666 mm)	307.5 in (7,810 mm)	296.6 in (7,533 mm)	302.3 in (7,678 mm)
Dump angle – fully raised	55°	55°	55°	55°
H. Dump height – fully raised, 45° dump	108.1 in (2,745 mm)	104.4 in (2,653 mm)	111.5 in (2,831 mm)	107.8 in (2,737 mm)
J. Bucket reach – fully raised, 45° dump	50.9 in (1,293 mm)	55.1 in (1,399 mm)	46.9 in (1,191 mm)	51.0 in (1,296 mm)
K. Bucket reach – 7 ft 0 in (2.13 m) height, 45° dump	69.9 in (1,776 mm)	71.9 in (1,826 mm)	67.7 in (1,721 mm)	69.8 in (1,774 mm)
L. Dig depth	2.5 in (63 mm)	2.6 in (65 mm)	2.5 in (62 mm)	2.6 in (67 mm)
Operating load – ISO Rigid Tires	8,755 lb (3,971 kg)	8,871 lb (4,024 kg)	8,948 lb (4,059 kg)	9,058 lb (4,109 kg)
Operating load – ISO Deflected Tires	7,883 lb (3,576 kg)	7,990 lb (3,624 kg)	8,077 lb (3,664 kg)	8,178 lb (3,709 kg)
Maximum material density – ISO Rigid Tires	2,918 lb/yd ³ (1,732 kg/m ³)	3,168 lb/yd ³ (1,880 kg/m ³)	3,579 lb/yd ³ (2,124 kg/m ³)	3,774 lb/yd ³ (2,239 kg/m ³)
Maximum material density – ISO Deflected Tires	2,628 lb/yd ³ (1,559 kg/m ³)	2,854 lb/yd ³ (1,693 kg/m ³)	3,231 lb/yd ³ (1,917 kg/m ³)	3,407 lb/yd ³ (2,022 kg/m ³)
Tipping load – ISO Rigid Tires: Straight 40° turn	20,330 lb (9,221 kg) 17,509 lb (7,942 kg)	20,584 lb (9,337 kg) 17,742 lb (8,048 kg)	20,741 lb (9,408 kg) 17,895 lb (8,117 kg)	20,981 lb (9,517 kg) 18,116 lb (8,217 kg)
Tipping load – ISO Deflected Tires: Straight 40° turn	19,002 lb (8,619 kg) 15,766 lb (7,152 kg)	19,241 lb (8,727 kg) 15,980 lb (7,248 kg)	19,415 lb (8,806 kg) 16,154 lb (7,327 kg)	19,640 lb (8,908 kg) 16,356 lb (7,419 kg)
Lift capacity: Full height Ground	13,929 lb (6,318 kg) 32,621 lb (14,797 kg)	14,074 lb (6,384 kg) 34,152 lb (15,491 kg)	14,197 lb (6,440 kg) 34,382 lb (15,596 kg)	14,337 lb (6,503 kg) 35,919 lb (16,293 kg)
Breakout force with tilt cylinder	22,941 lb (10,406 kg)	24,092 lb (10,928 kg)	25,446 lb (11,542 kg)	26,841 lb (12,175 kg)
Loader clearance circle with bucket	451.0 in (11,456 mm)	453.0 in (11,506 mm)	449.0 in (11,405 mm)	450.9 in (11,454 mm)

621G	JRB/ACS	JRB/ACS	JRB/ACS	JRB/ACS
Maximum rollback: Ground	57°/57°	57°/57°	57°/57°	57°/57°
Carry position	59°/59°	59°/59°	59°/59°	59°/59°
@ Full height	59°/59°	59°/59°	59°/59°	59°/59°
Maximum grading angle with bucket – back dragging	63°/62°	64°/63°	62°/60°	63°/62°
SAE bucket capacity – struck	2.60 yd ³ (1.99 m ³)	2.40 yd ³ (1.83 m ³)	2.15 yd ³ (1.64 m ³)	2.05 yd ³ (1.57 m ³)
Heaped	3.00 yd ³ (2.29 m ³)	2.80 yd ³ (2.14 m ³)	2.50 yd ³ (1.91 m ³)	2.40 yd ³ (1.83 m ³)
Bucket width – outside	102.4 in (2,602 mm)	102.1 in (2,593 mm)	102.4 in (2,602 mm)	102.1 in (2,593 mm)
Bucket weight	2,797 lb/3,131 lb (1,269 kg)/(1,420 kg)	2,721 lb/3,053 lb (1,234 kg)/(1,385 kg)	2,610 lb/2,918 lb (1,184 kg)/(1,324 kg)	2,532 lb/2,840 lb (1,149 kg)/(1,288 kg)

NOTE: *Z-Bar performance data shown with full counterweight. Performance data unit equipped with 20.5-R25 Michelin XTLA (L2 Radial) tires, ROPS cab with heater and A/C, full counterweight, standard batteries, front and rear fenders, full fuel and 165 lb (75 kg) operator. Specifications per SAE J732, J1234, J695, J742 and J818.

STANDARD EQUIPMENT

Operator Environment

See page 1.

ENGINE

FPT F4HFE613W
Tier 4 Final Certified
Selective Catalytic Reduction (SCR) with Diesel Oxidation Catalyst
Selectable work modes:
Maximum Power
Smart Mode
Turbocharger
Charge air cooling
Automatic belt tensioner
Integral engine oil cooling
Fuel filter with water trap
Dual-element dry-type air cleaner
Hydraulic-driven cooling fan
Air-cooled radiator
Mid-mounted cooling module with hydraulically driven auto-reversing fan
Engine block heater
Common rail electronic fuel injection

LOADER

See page 2 – Operating weight,
Other specifications

DRIVETRAIN

4-wheel drive
4F/3R Selectable autoshift /manual shift transmission
Electronic Control Module – programmable, computer controlled proportional shifting with programmable gear selection
Onboard diagnostics
Single lever electronic shift control
F/N/R switch in loader control handle
Downshift button
Torque converter
Limited-slip differentials – Z-Bar
Outboard planetary axles
Transmission oil cooler
Brake pedal transmission disconnect – declutch
Hydraulic wet disc brakes
Spring-applied hydraulic release parking brake
Limp-Home Mode
Greaseable rear axle trunnion
3-piece rims

HYDRAULICS

Adjustable Electro-hydraulic - EH loader control with one auxiliary function and 3 configurable buttons
Adjustable EH controls:
Smooth
Moderate
Aggressive
Auxiliary Hydraulics
Ride Control™
Locking hydraulics for hydraulic coupler
EH Parallel Lift
Low-effort steering
Hydraulic driven cooling fan
Diagnostic quick couplers
Hydraulic oil cooler

ELECTRICAL

Alternator and voltage regulator
Battery isolator/electrical disconnect
120 amp alternator
(2) 700 CCA 12-volt batteries
Electric starter
Lights:
Integrated 4-corner strobe
2 Front and 2 rear halogen flood lights
2 Front driving headlights – high/ low beam with integrated turn signals
2 LED stop/ tail lights with integrated turn signals
Key start /stop switch
Backup alarm
Centrally located fuse box with all electrical circuits protected
Remote jump start posts

OTHER

Electric hood lift
Front and rear fenders, partial coverage
External rear view mirrors
Heavy counterweight
Drawbar hitch
Articulation locking bar
Lift arm locking bar
Lift and tie-down points – front /rear
Rear frame side covers
License plate brackets; front bracket and lit rear bracket
Rubber steering stops
Grouped remote-mounted ecology drains:
Engine oil
Engine coolant
Hydraulic oil

OPTIONAL EQUIPMENT

OPERATOR ENVIRONMENT

Cloth-covered heated air-suspension seat with headrest
Sound Shield noise suppression package
Bluetooth radio, 12V AM/FM with auxiliary input
Cab convenience package:
Rear sun shade, interior mirror, under the seat drawer, coat hook, 12V accessory port, and an ash tray
In cab powered cooler box
In cab accessory mount
Rear view camera
External heated rear view mirrors
Front LED driving/headlights
LED front and rear work lights – 4 front, 2 rear

DRIVETRAIN

Heavy-duty axles:
With locking front differential and open rear differential
Cold weather package:
Heavy-duty (2) 950 CCA 12V batteries
Fuel heater
Hydraulic oil cooler bypass
Low temperature hydraulic oil
Fast-warm hydraulic valve

HYDRAULICS

Secondary steering
Integrated Payload System
Tire Pressure Monitoring System
2-spool loader valves with joystick loader control
4-function loader valve with joystick loader control and two proportional auxiliary roller switches

LOADER

XT tool carrier version
Attachment auxiliary hydraulics
Coupler systems – JRB or ACS compatible
Buckets – see pages 4 through 8

TIRES

20.5x25 L2 bias (16 ply) – dirt /traction
20.5 x25 L3 bias (16 ply) – rock
20.5-R25 L2 radial – dirt /traction
20.5-R25 L3 radial – rock
20.5-R25 radial Michelin SnoPlus
Axle oscillation stops

GUARDING

Skid plate, transmission and front chassis bottom guards

ADVANCED ENGINE AIR FILTRATION

Heavy Debris cooling system:
Slanted cooling module cover
Auto reversing fan
Increased cooling fin spacing
Added cooling module sealing
Sy-Klone® ejector type pre-cleaner

OTHER

Additional RH steps and platform with standard or wide fenders
12.4 mph (20 kph) maximum speed control
Special paint
Standard fenders with right and left hand steps
Wide full coverage fenders with right and left hand steps



CASE Corporation reserves the right to make improvements in design or changes in specifications at any time without incurring any obligation to install them on units previously sold. The specifications, descriptions, and illustrative materials contained here reflect correctly the data known up to the publication date, but are subject to changes with no previous notice. The illustrations may include optional equipment and accessories and may not include all standard equipment.

CCEIO136 - 05/2022

CaseCE.com



Garín Trade Office

ARGENTINA
Ávalos 2829 Edif. 1 Piso 4°,
Complejo Urbana
Vicente López (1605) Bs. As.,
Argentina. Phone +54 (11) 2034 1400

Manufacturing plants

BRAZIL
Contagem – Minas Gerais – Brazil
Av. General David Sarnoff, 2237
Inconfidentes – C. P. 32210-900
Phone +55 31 2104-3392

Sorocaba – São Paulo – Brazil
Av. Jerome Case, 1.801
Éden – CEP 18087-220
Phone +55 15 3334-1700