



## ENGINE

Model	FPT F5BFL413A
Emissions Certification	Tier 4 Final
Type	Diesel 4-stroke, Turbocharged
Cylinders	4
Bore/Stroke	3.90 x 4.33 in (99 x 110 mm)
Displacement	207 in <sup>3</sup> (3.4 L)
Fuel injection	Direct, high pressure common rail – HPCR
Fuel	Diesel
Engine speeds*	RPM
Rated speed – full load	2200
Low idle	900 – 1000
High idle – no load	2320 – 2430
Horsepower @ 2200 RPM:	
Gross	110 hp (82 kW)
Net	108 hp (81 kW)
Maximum torque @ 1400 RPM:	
Gross	339 lb-ft (460 N-m)
Net	338 lb-ft (459 N-m)
Torque rise at rated speed	29% +/- 5%
Radiator:	
Core type	Square wave
Core size area	486 in <sup>2</sup> (3 145 cm <sup>2</sup> )
Rows of tubes	4
Viscous Fan:	
Style	9 blade viscous suction
Diameter	19.68 in (500 mm)
Ratio	1.4:1
Pump operating angle ratings:	
Side to side	Rated 35°
Fore and aft	Rated 35°
Oil filtration	Replaceable, full flow cartridge

NOTE: \*Engine speeds w/ standard transmission.  
Meets federal emission regulations.

## DRIVETRAIN

Transmission – standard:  
Powershift S-Type, 4F-3R fully synchronized  
electric/hydraulic shifting w/ auto shift mode

Transmission – optional:  
4F-4R Power Shuttle Synchronmesh  
Transmission manual gear shift,  
fully synchronized

Specifications below apply to both Power  
Shuttle and Powershift S-Type transmission  
unless otherwise indicated.

Gear ratios	Forward/Reverse	
1st	5.603/4.643	
2nd	3.481/2.884	
3rd	1.584/1.313	
4th	0.793/0.657*	

Travel speeds	Forward	Reverse
	mph (kph)	mph (kph)
1st	4.1 (6.6)	4.9 (7.9)
2nd	6.5 (10.5)	7.8 (12.6)
3rd	13.8 (22.3)	16.5 (26.5)
4th	25.2 (40.6)	29.0 (46.7)*

Transmission – optional:  
Powershift H-Type, 4F-3R hydraulic clutch  
shifting w/ auto shift mode

Gear ratios	Forward/Reverse	
1st	5.533/4.549	
2nd	3.359/2.762	
3rd	1.533/1.260	
4th	0.811/–	

Travel speeds	Forward	Reverse
	mph (kph)	mph (kph)
1st	4.0 (6.4)	4.8 (7.7)
2nd	6.5 (10.5)	7.8 (12.6)
3rd	13.7 (22.0)	16.4 (26.4)
4th	23.0 (37.0)	–

Torque converter ratio	2.2
Differential lock	On-the-go push-button activation

Front 4WD/Rear axle:	
Differential ratio	2.1/2.5
Planetary hub ratio	6.0/6.4
Total reduction ratio	12.8/16.0

Service brakes:	
Individually applied, power assisted, hydraulically actuated, maintenance-free, self-adjusting, outboard mounted, wet disc, 2 per side.	
Total disc area	384 in <sup>2</sup> (0.25 m <sup>2</sup> )

Parking brakes	Trans Mounted spring-applied hydraulic release – SAHR
----------------	----------------------------------------------------------

NOTE: \*4R not available on Powershift S-type  
Travel speeds at 2306 engine  
RPM specified: w/ 21.0 L x 24.0 tires.

## ELECTRICAL

Voltage	12 Volts, negative ground
Alternator	160 amp
Battery	850 cold-cranking amps
Optional dual batteries:	850 cold-cranking amps each
Power plugs – 2	30 amps total

## OPERATOR ENVIRONMENT

ROPS/FOPS certified protective canopy;  
Anti-vandalism cover for dash – w/ canopy  
only; Rear fenders extensions; Coat hook w/  
garment strap; Interior rearview convex mirror;  
Non-suspension seat – 180° swivel – Vinyl; 2 in  
(50 mm) retractable seat belt; Cup holder/storage  
tray mounted on left-hand fender; Right-hand  
storage compartment w/ lid.

Gauges:  
Engine water temperature; Converter oil  
temperature; Fuel level; Tachometer/  
hourmeter; DEF level.

Warning lights:  
Air cleaner restriction; Alternator; A/C high  
pressure; Cold start; Engine oil pressure;  
Hydraulic oil filter bypass; Parking brake  
engagement; Low fuel; Water in fuel; Low DEF.

Audible alarms w/ diagnostics:  
Coolant temperature; Engine oil pressure;  
Parking brake engagement; Converter oil  
temperature; Shuttle engagement/seat  
position; Backup alarm; Low DEF.

Horn Dual switched front and rear

## OPERATING WEIGHT

### Configuration – SAE Transport:

No Operator, 4:1 Loader Bucket, E-hoe, Cab  
w/ Heat and AC, Ride Control, Eco Mode,  
Heavy Lift, Fully fueled, 24 in HD BH Bucket  
4 WD, Boom Guard, Big Front Counterweight,  
Quick Couple BH, BH aux., Pilot BH Controls,  
Galaxy 14-17.5 @ 50 psi front tires Goodyear  
21 L – 24 @ 28 psi Rear Tires.  
20,532 lb (9 309 kg)

### Add-on weights:

Cab-over canopy	309 lb (140 kg)
Fabricated stabilizer pads	141 lb (64 kg)
Counterweights	700 lb (318 kg)
Extendahoe®	1,100 lb (500 kg)
4WD w/ driveshaft guard	335 lb (152 kg)
	393 lb (178 kg)

## HYDRAULICS

**Pump:**  
Bosch Rexroth Series 31 Variable Displacement Axial Piston Pump, dual mode torque regulation, mode selected by solenoid

<b>Main relief pressure:</b>	
Standard	3,450 +/- 50 psi (238 +/- 3.5 bar)
Power Lift	3,625 +/- 50 psi (250 +/- 3.5 bar)

**Filtration:**  
7-micron, full flow replaceable cartridge on return line, condition indicator light for filter.

**Oil cooler** Heavy-duty

<b>Loader flow @ rated engine RPM:</b>	
	43 gpm @ 2,340 psi (162.6 L/min @ 161 bar)

**Loader control valve w/ pilot or manual backhoe controls:**  
Two or three-spool closed center sectional control valve. Single lever manual control for lift and tilt functions. The three-spool valve uses a proportional Electro-Hydraulic control for the auxiliary function. The lift lever has a positive hold "Float" position and a "return-to-dig" feature.

<b>Loader auxiliary hydraulics w/ proportional thumb switch w/ detent on loader control handle:</b>	
	0 to 43 gpm (0 to 162.6 L/min)

<b>Backhoe flow @ rated engine RPM:</b>	
	43 gpm @ 3,100 psi (162.6 L/min @ 214 bar)

**Manual backhoe control valve:**  
Six-spool monoblock open center control valve w/ seventh and eighth spool bolt-on sections. Features "Pro-Control" which includes custom designed spools for each individual function along w/ "swing cushioning" valve for zero-wag swing control. Basic control valve has an open center parallel circuit for all functions.

**Pilot backhoe control valve:**  
Six, seven, or eight spool sectional closed center control valve. Features "Pro-Control" which includes custom designed spools for each individual function along w/ "swing cushioning" valve for zero-wag swing control. Basic control valve is closed center, w/ circuits in parallel w/ a post-compensated, flow sharing feature for simultaneous operation of all circuits.

**1-way flow auxiliary hydraulics:**  
1-way flow hydraulic valve is equipped w/ an adjustable LS relief valve to control attachment pressure and a 6 position flow control selector for 6 detented, distinct flow settings.

**Actuation:**  
Manual backhoe controls – cab floor pedal  
Pilot controls – left-hand joystick

**2-way flow auxiliary hydraulics\*:**  
**Actuation:**  
Activate the 2-way flow switch located on the rear console  
Manual shift – 2-way flow linkage on far right of backhoe tower  
Pilot controls – left-hand joystick.

NOTE: \*Available w/ 1-way/2-way Aux. Hyd. option.

## SERVICE CAPACITIES

<b>Fuel tank</b>	35.0 gal (132.0 L)
<b>DEF tank</b>	3.6 gal (13.5 L)

<b>Hydraulic system:</b>	
Total	138 qt (130.7 L)
w/ Extendahoe®	144 qt (135.7 L)
Reservoir w/ filter	55 qt (52.4 L)
Reservoir w/o filter	53 qt (50.5 L)

<b>Transmission – total system:</b>	
2WD Standard	18 qt (17.0 L)
2WD Powershift S-Type	23 qt (21.7 L)
4WD Standard	21 qt (19.4 L)
4WD Powershift S-Type	22 qt (20.7 L)
4WD Powershift H-Type	19 qt (18.0 L)

<b>Front axle:</b>	
2WD each hub	0.8 qt (0.8 L)
4WD Differential	9.1 qt (8.6 L)
4WD Planetaries – each	1.1 qt (1.0 L)
<b>Rear axle:</b>	
Differential and planetaries	14.4 qt (13.6 L)
<b>Engine oil w/ filter</b>	
	8.5 qt (8.0 L)
<b>Cooling system:</b>	
w/ heater	19.0 qt (18.0 L)
w/o heater	18.3 qt (17.3 L)
<b>Window washer reservoir</b>	3.0 qt (2.8 L)

## OTHER SPECIFICATIONS

<b>Front tires:</b>	
2WD	14.0 L x 17.5, 10-ply Industrial Rib
4WD	14.0 L x 17.5, 10-ply SGL SS

<b>Rear tires:</b>	
2/4WD	21.0 L x 24.0, 10-ply R4

<b>Turning radius*: Curb to Curb:</b>	
2WD:	
Brakes on	11 ft 6 in (3.55 m)
Brakes off	12 ft 8 in (3.86 m)

4WD – engaged:	
Brakes on	12 ft 6 in (3.81 m)
Brakes off	14 ft 4 in (4.36 m)

4WD – disengaged:	
Brakes on	11 ft 8 in (3.55 m)
Brakes off	12 ft 8 in (3.86 m)

NOTE: \*Turning radius dimensions curb to curb w/ 21.0 L x 24.0 rear tires.

## LOADER BUCKET SIZES

Type	Width	Weight	Struck	Heaped Capacity
Long Lip Bucket with lift points and bolt-on cutting edge	93 in (2.36 m)	1,188 lb (539 kg)	1.1 yd <sup>3</sup> (0.84 m <sup>3</sup> )	1.3 yd <sup>3</sup> (0.99 m <sup>3</sup> )
	96 in (2.44 m)	1,415 lb (642 kg)	1.27 yd <sup>3</sup> (0.97 m <sup>3</sup> )	1.5 yd <sup>3</sup> (1.15 m <sup>3</sup> )
4 IN 1® Bucket	93 in (2.36 m)	1,685 lb (764 kg)	1.0 yd <sup>3</sup> (0.76 m <sup>3</sup> )	1.20 yd <sup>3</sup> (0.92 m <sup>3</sup> )

## BACKHOE BUCKET SIZES

Type	Width	Weight	Heaped Capacity
Universal Buckets	12 in (305 mm)	295 lb (134 kg)	3.40 ft <sup>3</sup> (0.10 m <sup>3</sup> )
	18 in (457 mm)	356 lb (162 kg)	5.30 ft <sup>3</sup> (0.15 m <sup>3</sup> )
	24 in (610 mm)	427 lb (194 kg)	7.70 ft <sup>3</sup> (0.22 m <sup>3</sup> )
	30 in (762 mm)	489 lb (222 kg)	10.20 ft <sup>3</sup> (0.29 m <sup>3</sup> )
	36 in (914 mm)	552 lb (251 kg)	12.70 ft <sup>3</sup> (0.36 m <sup>3</sup> )
High Capacity Buckets	24 in (610 mm)	447 lb (203 kg)	8.50 ft <sup>3</sup> (0.24 m <sup>3</sup> )
	30 in (762 mm)	502 lb (228 kg)	10.60 ft <sup>3</sup> (0.30 m <sup>3</sup> )

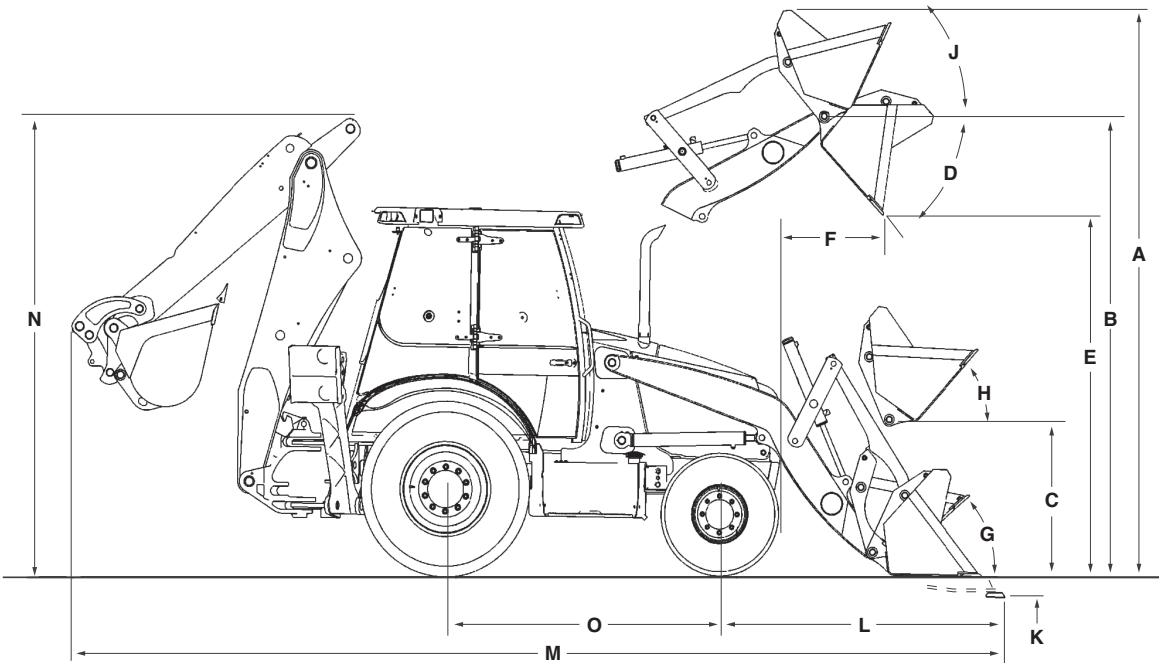

Line drawings are for illustrative purpose only and may not be exact representation of unit.

### LOADER DIMENSIONS

	Long Lip Bucket	4 IN 1® Bucket
<b>A.</b> Overall operating height – fully raised	13 ft 11 in (4.24 m)	13 ft 10 in (4.22 m)
Height to:		
<b>B.</b> Bucket hinge pin fully raised	11 ft 6 in (3.50 m)	11 ft 6 in (3.50 m)
<b>C.</b> Bucket hinge pin at SAE carry	12.8 in (325 mm)	12.8 in (325 mm)
<b>D.</b> Dump angle at full height	45°	45°
<b>E.</b> Dump clearance at full height, 45° dump:		
Bucket	8 ft 11 in (2.72 m)	9 ft 1 in (2.77 m)
Clam open	–	9 ft 10 in (3.01 m)
<b>F.</b> Dump reach at full height, 45° dump – from bumper:		
Bucket	29.2 in (741 mm)	27.8 in (707 mm)
Clam open	–	13.8 in (351 mm)
Bucket rollback:		
<b>G.</b> @ Groundline	40°	41°
<b>H.</b> @ SAE carry	46°	46°
<b>J.</b> @ Full height	Adjustable	Adjustable
<b>K.</b> Digging depth below grade:		
Bucket flat	6.2 in (157 mm)	5.9 in (150 mm)
Clam open – dozing	–	3.5 in (89 mm)
<b>L.</b> Reach from front axle centerline – bucket on ground	6 ft 7 in (2.05 m)	6 ft 5 in (1.99 m)
Lift capacity to full height – calculated values	8,202 lb (3 721 kg)	7,807 lb (3 541 kg)
Breakout force – calculated values:		
Lift cylinders	11,463 lb (5 099 daN)	11,225 lb (4 993 daN)
Dump cylinders	12,776 lb (5 683 daN)	13,717 lb (6 102 daN)
Bucket cutting edge width	92.7 in (2.36 m)	93.0 in (2.36 m)
Maximum grading angle	106°	106°
Maximum clam opening	–	38.3 in (972 mm)
Moldboard height	–	36.8 in (934 mm)
Raising time to full height	3.7 sec	3.7 sec
Bucket dumping time	2.0 sec	2.0 sec
Lowering time:		
Power down	2.5 sec	2.5 sec
Return-to-dig	3.8 sec	3.8 sec
Clam:		
Open time	–	1.3 sec
Close time	–	1.1 sec

NOTE: Loader dimensions taken with 4WD.

## DIMENSIONS

	Standard Backhoe	Extendahoe®	
		Retracted	Extended
<b>M. Overall transport length:</b>			
Long Lip bucket	23 ft 10 in (7.25 m)	23 ft 10 in (7.25 m)	–
4 IN 1® bucket	23 ft 7 in (7.20 m)	23 ft 7 in (7.20 m)	–
Overall transport width	7 ft 9 in (2.36 m)	7 ft 9 in (2.36 m)	–
Height:			
To top of canopy	8 ft 9 in (2.68 m)	8 ft 9 in (2.68 m)	8 ft 9 in (2.68 m)
To top of cab	8 ft 11 in (2.71 m)	8 ft 11 in (2.71 m)	8 ft 11 in (2.71 m)
To top of exhaust stack	8 ft 9 in (2.67 m)	8 ft 9 in (2.67 m)	8 ft 9 in (2.67 m)
<b>N. Transport</b>	11 ft 7 in (3.54 m)	11 ft 8 in (3.54 m)	–
Ground clearance at backhoe frame	14.2 in (360 mm)	14.2 in (360 mm)	14.2 in (360 mm)
Angle of departure	18.7°	18.7°	18.7°
Front wheel tread:			
14.0 L x 17.5 Industrial Rib	74.3 in (1.89 m)	74.3 in (1.89 m)	–
14.0 L x 17.5	74.3 in (1.89 m)	74.3 in (1.89 m)	–
Rear wheel tread:			
21.0 L x 24.0	69.6 in (1.77 m)	69.6 in (1.77 m)	–
<b>O. Wheelbase:</b>			
2WD	84.0 in (2.13 m)	84.0 in (2.13 m)	–
4WD	84.5 in (2.15 m)	84.5 in (2.15 m)	–

NOTE: Dimensions taken with 21.0 L x 24.0 rear tires and 14.5/75.0 L x 16.1 front tires except that data marked 4WD is taken with 14.0 L x 17.5 front tires.

## CYLINDERS

	Bore Diameter	Rod Diameter	Stroke	Closed Length
Loader:				
Lift – 2	3.50 in (88.9 mm)	1.875 in (47.6 mm)	29.13 in (740.0 mm)	41.54 in (1 055.0 mm)
Dump – 2	3.25 in (82.6 mm)	1.75 in (44.5 mm)	20.33 in (516.5 mm)	30.78 in (781.8 mm)
4 IN 1® clam – 2	3.00 in (76.2 mm)	1.75 in (44.5 mm)	9.08 in (230.6 mm)	19.62 in (498.3 mm)
Backhoe:				
Boom	5.50 in (139.7 mm)	2.75 in (69.9 mm)	40.57 in (1 030.5 mm)	57.05 in (1 449.0 mm)
Dipperstick	5.25 in (133.4 mm)	2.75 in (69.9 mm)	23.53 in (597.7 mm)	38.49 in (977.7 mm)
Bucket	3.50 in (88.9 mm)	2.50 in (63.5 mm)	38.95 in (989.4 mm)	51.78 in (1 315.2 mm)
Extendahoe®	3.00 in (76.2 mm)	1.75 in (44.5 mm)	48.03 in (1 220.0 mm)	64.02 in (1 626.0 mm)
Swing – 2	4.00 in (101.6 mm)	2.00 in (50.8 mm)	11.50 in (292.0 mm)	24.44 in (620.8 mm)
Stabilizer – 2	5.25 in (133.4 mm)	2.50 in (63.5 mm)	20.40 in (518.1 mm)	33.57 in (852.7 mm)

## AXLE RATINGS

	Front – 2WD	Rear	Front – 4WD
Maximum static	65,506 lb (29 713 kg)	70,848 lb (32 136 kg)	67,883 lb (30 791 kg)
Dynamic operating	44,261 lb (20 077 kg)	49,494 lb (22 450 kg)	47,426 lb (21 512 kg)
Static operating	17,704 lb (8 031 kg)	19,798 lb (8 980 kg)	18,969 lb (8 604 kg)
Oscillation – front axle	22° total – 11° each side	–	22° total – 11° each side

**BACKHOE LIFT CAPACITIES**

	Standard Backhoe		Extendahoe®			
	Standard	Power Lift	Retracted		Extended	
			Standard	Power Lift	Standard	Power Lift
Boom Lift	Lift Capacity lb (kg)	Lift Capacity lb (kg)	Lift Capacity lb (kg)	Lift Capacity lb (kg)	Lift Capacity lb (kg)	Lift Capacity lb (kg)
+18 ft (5.50 m)	—	—	—	—	2,548 (1 156)	2,710 (1 229)
+16 ft (4.87 m)	—	—	—	—	2,783 (1 262)	2,961 (1 343)
+14 ft (4.27 m)	3,942 (1 788)	4,177 (1 895)	3,688 (1 673)	3,923 (1 779)	2,967 (1 346)	3,156 (1 431)
+12 ft (3.66 m)	4,160 (1 887)	4,409 (2 000)	3,898 (1 768)	4,147 (1 881)	3,037 (1 378)	3,231 (1 465)
+10 ft (3.05 m)	4,204 (1 907)	4,456 (2 021)	3,937 (1 786)	4,188 (1 900)	3,051 (1 384)	3,246 (1 472)
+8 ft (2.44 m)	4,180 (1 896)	4,430 (2 009)	3,908 (1 773)	4,158 (1 886)	3,052 (1 384)	3,247 (1 473)
+6 ft (1.83 m)	4,128 (1 873)	4,374 (1 984)	3,853 (1 748)	4,099 (1 859)	3,037 (1 378)	3,231 (1 466)
+4 ft (1.22 m)	4,064 (1 843)	4,305 (1 953)	3,785 (1 717)	4,027 (1 827)	3,011 (1 366)	3,203 (1 453)
+2 ft (0.61 m)	4,001 (1 815)	4,239 (1 923)	3,720 (1 687)	3,957 (1 795)	2,983 (1 353)	3,174 (1 440)
<b>Ground Level</b>	3,942 (1 788)	4,175 (1 894)	3,657 (1 659)	3,891 (1 765)	2,970 (1 347)	3,160 (1 433)
-2 ft (0.61 m)	3,893 (1 766)	4,123 (1 870)	3,606 (1 635)	3,836 (1 740)	2,946 (1 336)	3,134 (1 422)
-4 ft (1.22 m)	3,863 (1 752)	4,091 (1 856)	3,572 (1 620)	3,800 (1 724)	2,929 (1 329)	3,116 (1 413)
-6 ft (1.83 m)	3,861 (1 751)	4,088 (1 854)	3,565 (1 617)	3,793 (1 720)	2,924 (1 326)	3,111 (1 411)
-8 ft (2.44 m)	3,910 (1 774)	4,141 (1 878)	3,609 (1 637)	3,839 (1 741)	2,941 (1 334)	3,129 (1 419)
-10 ft (3.05 m)	4,088 (1 854)	4,329 (1 964)	3,776 (1 713)	4,017 (1 822)	2,985 (1 354)	3,175 (1 440)
-12 ft (3.66 m)	4,245 (1 925)	4,494 (2 038)	3,900 (1 769)	4,149 (1 882)	3,102 (1 407)	3,300 (1 497)
-14 ft (4.27 m)	—	—	—	—	3,307 (1 500)	3,519 (1 596)
<b>Dipper Lift</b>						
+16 ft (4.87 m)	—	—	—	—	4,312 (1 956)	4,312 (1 956)
+14 ft (4.27 m)	6,102 (2 768)	6,102 (2 768)	5,853 (2 655)	5,853 (2 655)	4,020 (1 823)	4,020 (1 823)
+12 ft (3.66 m)	6,651 (3 017)	6,651 (3 017)	6,409 (2 907)	6,409 (2 907)	5,252 (2 382)	5,252 (2 382)
+10 ft (3.05 m)	6,891 (3 126)	6,891 (3 126)	6,650 (3 016)	6,650 (3 016)	4,849 (2 200)	4,849 (2 200)
+8 ft (2.44 m)	7,147 (3 243)	7,147 (3 243)	6,903 (3 131)	6,903 (3 131)	4,945 (2 243)	4,945 (2 243)
+6 ft (1.83 m)	7,178 (3 256)	7,178 (3 256)	6,928 (3 142)	6,928 (3 142)	4,670 (2 118)	4,670 (2 118)
+4 ft (1.22 m)	8,226 (3 731)	8,226 (3 731)	7,953 (3 608)	7,953 (3 608)	4,424 (2 007)	4,424 (2 007)
+2 ft (0.61 m)	—	—	—	—	5,103 (2 315)	5,103 (2 315)

NOTE: Boom and Dipper Lift Capacities are rated per SAE J31 and are 87% of the maximum hydraulic lift force available with the specified options.

**BACKHOE OPERATIONAL DATA**

	Standard Backhoe	Extendahoe®	
		Retracted	Extended
Digging depth:			
Maximum	15 ft 6 in (4.72 m)	15 ft 6 in (4.72 m)	19 ft 6 in (5.94 m)
Maximum with hi-capacity bucket	16 ft 0 in (4.88 m)	16 ft 0 in (4.88 m)	20 ft 0 in (6.10 m)
2 ft (610 mm) flat bottom	15 ft 5 in (4.69 m)	15 ft 5 in (4.69 m)	19 ft 5 in (5.92 m)
8 ft (2.44 m) flat bottom	14 ft 5 in (4.40 m)	14 ft 5 in (4.40 m)	18 ft 8 in (5.63 m)
Overall reach from:			
Rear axle centerline	23 ft 3 in (7.10 m)	23 ft 3 in (7.10 m)	27 ft 2 in (8.28 m)
Swing pivot	19 ft 7 in (5.98 m)	19 ft 7 in (5.98 m)	23 ft 6 in (7.17 m)
Loading height	13 ft 1 in (4.00 m)	13 ft 1 in (4.00 m)	15 ft 9 in (4.81 m)
Loading reach – dipper retracted	5 ft 1 in (1.56 m)	5 ft 1 in (1.56 m)	8 ft 1 in (2.47 m)
Swing arc	180°	180°	180°
Bucket rotation:			
Mechanical coupler	198.0°	198.0°	198.0°
Hydraulic coupler – Extendahoe® dipper	194.8°	194.8°	194.8°
Hydraulic coupler – standard dipper	198.0°	198.0°	198.0°
Stabilizer spread – operating – centers:			
Flip pad	10 ft 9 in (3.26 m)	10 ft 9 in (3.26 m)	10 ft 9 in (3.26 m)
Cast pad	11 ft 1 in (3.37 m)	11 ft 1 in (3.37 m)	11 ft 1 in (3.37 m)
Digging force:			
Bucket cylinder – SAE rated 3,460 psi	15,132 lb (67 310 N)	15,132 lb (67 310 N)	15,132 lb (67 310 N)
Bucket cylinder – Power Lift	15,853 lb (70 520 N)	15,853 lb (70 520 N)	15,853 lb (70 520 N)
Dipper cylinder – SAE rated 3,460 psi	10,575 lb (47 041 N)	10,575 lb (47 041 N)	7,392 lb (32 882 N)
Dipper cylinder – Power Lift	11,080 lb (49 285 N)	11,080 lb (49 285 N)	7,744 lb (34 450 N)
Leveling angle:			
Flip pad	11.2°	11.2°	11.2°
Cast pad	12.0°	12.0°	12.0°

NOTE: Lift capacities apply straight to the rear of prime mover. 4WD equipped with 24 in (610 mm) Universal HD trenching bucket and Case coupler except as noted.

## STANDARD EQUIPMENT

### OPERATOR ENVIRONMENT

See page 1

### ENGINE

FPT F5BFL413A diesel  
Selective Catalytic Reduction – SCR  
Aspirated air cleaner – replaceable dual element dry type with radial seal  
Fuel filter with water trap  
Radiator with de-aeration bottle  
Antifreeze to -34° F (-37° C)  
Electronic throttles – foot and rotary hand  
Self adjusting belt  
High Pressure Common Rail computer controlled injection with diagnostic features  
Engine ECO Mode – Detent on backhoe hand throttle, push button switch on dash  
Auto Engine Idle  
Auto Engine Shutdown  
Auto Protection Shutdown

### DRIVETRAIN

Powershift S-Type transmission, 4F-3R fully synchronized electronic transmission controller, kick down in loader control lever and auto shift mode – 2WD or 4WD  
Front axle:  
2WD heavy-duty front axle with 14.0 L x 17.5 tires with Industrial Rib tread  
4WD heavy-duty mechanically driven front axle with 14.0 L x 17.5 tires and drive shaft guard  
Rear axle:  
2/4WD heavy-duty outboard planetary drive with 21.0 L x 24.0 tires  
Torque converter – 11.8 in (300 mm)  
On-the-go electric 4WD control  
Electric F/R shuttle control  
Electric differential lock control, push-button  
Park brake, spring-applied hydraulic release – SAHR

### HYDRAULICS

Ground level remote hydraulic test ports  
Variable displacement axial piston pump  
Pump:  
43 gpm @ 3,000 psi  
(162.6 L/min @ 207 bar)  
Heavy-duty hydraulic oil cooler  
7-micron, spin on oil filter

### LOADER

Bucket position indicator; Lifting lugs on standard bucket; Single lever control with self-leveling and return-to-dig; Hand operated clutch disconnects on loader and shift levers, single lever 4-function loader control: lift, dump, clutch cut-out, differential lock

### BACKHOE

Over center design, Fabricated “S” boom; Pro Control System; Dipperstick integrated serrated gripper teeth; Case mechanical coupler; Power Lift

### OTHER

Front tire 14.0 L x 17.5, 10 PR – 4WD  
Rear tire 21.0 L x 24.0, 10 PR  
Forward tilt engine hood  
Replaceable, molded front bumpers  
Front/Rear tie downs  
Reflective logos  
Signal Lights – cab and canopy:  
2 rear tail/stop  
2 front flashers/turn  
2 rear flashers/turn  
Working/Driving Lights – cab and canopy:  
Adjustable halogen work lights – 55 W:  
4 front  
2 side – one left, one right  
4 rear

### TELEMATICS

CASE SiteWatch™ Telematics – includes hardware and a 3-yr Advanced data subscription

### WARRANTY

1-Year/Unlimited-Hour Full-Coverage Base Limited Warranty  
2-Year/2,000-Hour Extended Engine Warranty

## OPTIONAL EQUIPMENT

### OPERATOR ENVIRONMENT

Speed selectable Auto Ride Control – 4WD models

Standard Ride Control – 2WD models

Comfort Steering with two-speed steering pump and 3rd/4th gear cutout

Deluxe Canopy with glass windshield, windshield wiper, windshield washer, floor mat, 85 dba sound level, two additional front lights, two additional rear lights and anti-vandalism cover

ROPS/FOFS certified protective cab available in LH Door or 2 door with heat, A/C, defroster, door activated dome light, 4 front, 4 rear and 2 adjustable side lights, tilt steering wheel, floor mat, tinted glass, radio ready, front and rear wiper and fender extensions

Deluxe Cab package with deluxe interior, viscous fan, pull-down sun visor and 72 dba sound level

Mechanical suspension seat with flip-up armrests, 180° swivel, adjustable seat and weight, backrest angle, lumbar and cushion angle – cab units cloth or vinyl, canopy units vinyl only

Air suspension seat with flip-up armrests, 180° swivel, electric height adjustment, adjustable backrest – lumbar and cushion angle – cab units cloth or vinyl, canopy units vinyl only

Heated seat option for vinyl and cloth Air suspension seats – cab units cloth or vinyl, canopy units vinyl only

Radio, AM/FM Stereo/WB, MP3 auxiliary input – cab models

3 in (75 mm) seat belt for mechanical and air-suspension seat

### ENGINE

Cold Weather Starting Aid:  
Dual 12 volt batteries, glow plugs, engine block heater and heated CCV hose

Severe Cold Weather Starting Aid:  
Synthetic transmission, hydraulic and engine oil – order with cold weather starting aid

### DRIVETRAIN

Standard Powershuttle, 4F-4R Power Shuttle Synchronesh transmission

Powershift H-Type transmission, 4F-3R hydraulic clutch shifting with auto function

### LOADER

Auxiliary hydraulics for loader-mounted equipment with thumb-operated proportional control

Hydraulic front quick coupler

Loader linkage without loader bucket

Tool portfolio of additional attachments

Buckets – see page 2

### BACKHOE

1-way Auxiliary backhoe hydraulics for hammers, plate compactors or similar 1-way flow attachments

1-way/2-way Auxiliary backhoe hydraulics for hammers, plate compactors or similar 1-way flow attachments or switch to 2-way flow for thumbs, augers or similar 2-way flow attachments

Bolt-on hardened gripper teeth

Extendahoe®

Two-lever control – backhoe or Extendahoe®

Pilot operated control system:  
Fingertip proportional Electro-Hydraulic stabilizer controls

Thumb-operated proportional Electro-Hydraulic Extendahoe® control

Thumb-operated horn button

Thumb-operated auxiliary hydraulic control

Infinitely adjustable towers

In-cab switchable “excavator to backhoe” control pattern change Standard dipper

Flip over stabilizer pads

Cemetery/Street pads

Hydraulic bucket coupler

Universal coupler – CAT/Deere compatible

Buckets – see page 2

### OTHER

Front tires:  
14.0 L x 17.5 10 PR

Rear tires:  
21 L x 24, 10 PR

Special paint

Tool box – bolt-on, step-mounted

Front counterweights:  
700 lb and 1,100 lb (318 kg and 500 kg)

Rotating beacon

LED Working/Driving Light Package:  
4 front  
4 rear  
2 side

Chaff Screen – Additional fine mesh screen in front of standard grille

Locking DEF/Fuel covers

Front Fenders

