



ENGINE

Model	FPT F5B FL413 E*B002
Emissions Certification	Tier 4 Final
Type	Diesel, Turbo – Direct Injection
Cylinders	4
Bore/Stroke	3.9 x 4.3 in (99 x 110 mm)
Displacement	207 in ³ (3.4 L)
Fuel injection	Direct
Fuel	#2 Diesel
Fuel filter:	
Pre-filter	Beta (30) = 200/spin-on
Main filter	Beta (4) = 20/spin-on
Air intake	Turbocharged w/ waste gate and external cooled EGR
Exhaust aftertreatment	Selective Catalytic Reduction (SCR)
Cooling	Liquid
Engine speeds	RPM
High idle – no load	2500 +/- 25
Rated – full load	2500
Low idle	1150 +/- 25
Horsepower @ 2500 RPM – SAE J1349:	
Gross	90 hp (67 kW)
Net	84 hp (63 kW)
Peak torque @ 1400 RPM	282 lb-ft (383 N-m)
Radiator:	
Core type	Aluminum bar and plate
Core size area	319 in ² (0.206 m ²)
Rows of tubes x columns	21
Cap pressure	16 +/- 2 psi (1.10 +/- 0.14 bar)
Fan:	
Diameter	22 in (560 mm)
Ratio	0.96:1 standard, 1.1:1 high-flow
Water pump:	
Style	Centrifugal
Flow	47.8 gpm (181 L/min)
Engine lubrication pump:	
Rotor pump w/ deep sump pan, plate cooler and pressurized under-piston nozzles	
Pump operating angle ratings:	
Side to side	45°
Bucket up	35°
Bucket Down	45°

LIFT GEOMETRY

Radial Lift

DRIVETRAIN

Drive pump controls	Servo-assist mechanical
Pump to engine ratio	1:1
Displacement	2.81 in ³ (46 cm ³)
Flow @ rated engine RPM:	
@ 97% efficiency	29.4 gpm (111 L/min)
Charge pressure	360 psi (24.5 bar)
System relief pressure	5,220 psi (360 bar)
Drive pump controls	Electro-hydraulic
Pump to engine ratio	1:1
Displacement	2.75 in ³ (45 cm ³)
Flow @ rated engine RPM:	
@ 97% efficiency	28.8 gpm (109 L/min)
Charge pressure	362 psi (25.0 bar)
System relief pressure	5,220 psi (360 bar)
Drive motors:	
Max. displacement	3.10 in ³ (50.9 cm ³)
Displacement – optional:	
High speed	2.02 in ³ (33.1 cm ³)
Motor RPM @ high idle and 97% efficiency:	
2-speed	156
Motor torque @ max. displacement and relief pressure, calculated @ 5,220 psi (360 bar):	4,654 lb-ft (6 310 N-m)
Travel speed:	
Low range	5.1 mph (8.2 kph)
High range	8.0 mph (12.9 kph)
Final drive:	
Planetary gearbox w/ 2-speed motor	
Tractive effort	7,414 lb (3 370 kg)
Parking brake:	
Type	Spring-applied, hydraulic release multiple disc.
Engagement	Depress on/off brake button on handle or instrument panel, raise seat bar, get off seat or stop engine.

ELECTRICAL

Alternator	160 amp
Starter	4.29 hp (3.2 kW)
Battery	12-volt low-maintenance 1,000 cold-cranking amps @ 0° F (-18° C°)

OPERATOR ENVIRONMENT

Enclosed Cab w/ Heater and AC; Fully sealed and pressurized – FSP; Glass door w/ wiper and washer; Sliding side windows – removable; Heater and air conditioner; AM/FM radio w/ 2 speakers; Keyless start ignition; Tilt ROPS/FOPS; Rear window w/ emergency escape; Deluxe cloth, air suspension seat, w/ 2 in (51 mm) retractable 3 point lap seat belt w/ heater and lumbar support; Hand and Foot throttle; Alarm package – back-up and horn; Rearview mirror; Headliner; Dome Light; Top window; Cup holder; 12V Power plug socket; Foot rest; Seat Pocket; Padded seat bar

w/ integral armrests; Loader control lockout system; Electric parking brake control; Operator's compartment floor cleanout; Proportional auxiliary hydraulic control – on joystick; Advanced Instrument Cluster w/ digital hour meter, tachometer, Fuel level LCD bar graph w/ alarm, diagnostic features and security lockout.

Warning lights with alarms:

Engine coolant temperature; Engine oil pressure; Engine malfunction; Hydraulic charge pressure; Hydraulic filter restriction; Hydraulic oil temperature; Critical system stop, Engine system, Hydraulic system, Electrical and diagnostic system.

Warning alarms:

Battery voltage – plus display; Oil service.

Indicator light:

Engine preheat; Parking brake; Seat bar reminder.

OPERATING WEIGHT

Unit equipped w/ open cab; 165 lb operator; 78 in Dirt & Foundry bucket; full of fuel:	10,000 lb (4 536 kg)
Shipping weight	9,656 lb (4 380 kg)
Add-on weights:	
Side cab glass	47 lb (21.3 kg)
Polycarbonate cab door	75 lb (34.0 kg)
Glass cab door w/ wiper	75 lb (34.0 kg)
Suspension seat	22 lb (10.0 kg)
Additional counterweight	600 lb (273.0 kg)

HYDRAULICS

Implement pump type	Gear
Displacement:	
Standard aux.	2.23 in ³ (36.6 cm ³)
High-flow aux.	1.24 in ³ (20.4 cm ³)
Standard flow @ rated engine RPM:	
@ 100% efficiency	24.2 gpm (91.5 L/min)
Optional high-flow @ rated engine RPM:	
@ 100% efficiency	37.6 gpm (142.5 L/min)
Enhanced high-flow @ rated engine RPM:	
@ 100% efficiency	35.0 gpm (132.5 L/min)
Loader control valve:	
Type	3 spool/open center/series - series
Relief pressure	3,046 psi (210 bar)
Port relief pressures:	
Loader raise	3,263 psi (225 bar)
Bucket curl	3,770 psi (260 bar)
Bucket dump	1,160 psi (80 bar)
Hydraulic lines:	
Tubing	37° JIC Flare
Loop hoses	SAE 100 R19
Hydraulic oil cooler:	
Number of fins	10 per inch (3.94 per cm)
Number of tube rows x columns	9 bar/plate
Area	130.7 in ² (843.2 cm ²)
Hydraulic filter	Beta (4) = 75/spin-on

HYDRAULICS CONT.

Lift cylinders:	
Bore diameter	2.75 in (69.85 mm)
Rod diameter	1.75 in (44.5 mm)
Stroke	32.20 in (817.9 mm)
Closed length	45.60 in (1 158.0 mm)
Bucket cylinders:	
Bore diameter	3.0 in (76.2 mm)
Rod diameter	1.5 in (38.1 mm)
Stroke	16.4 in (410.0 mm)
Closed length	24.0 in (610.0 mm)

SERVICE CAPACITIES

Fuel Tank	25.5 gal (96.5 L)
Engine oil w/ filter	8.9 qt (8.5 L)
Hydraulic system:	
Reservoir	6.0 gal (22.7 L)
Total	11.9 gal (45.4 L)
Diesel Exhaust Fluid (DEF) Tank	2.8 gal (10.7 L)

PERFORMANCE SPECS

Rated operating capacity – ROC*:	
35% of tipping load	2,380 lb (1 079 kg)
50% of tipping load	3,400 lb (1 542 kg)
w/ additional counterweight	3,600 lb (1 633 kg)
Tipping load*	6,800 lb (3 084 kg)
Breakout forces @ 3,150 psi (217 bar)*:	
Bucket cylinders	8,700 lb (38.7 kN)
Lift cylinders – hydraulic limit	7,760 lb (34.5 kN)
Cycle times:	
Raise	4.4 sec
Lower	2.6 sec
Dump	2.6 sec
Roll back	2.0 sec

NOTE: *Measured using 78 in (1.98 m) foundry/ excavating bucket.

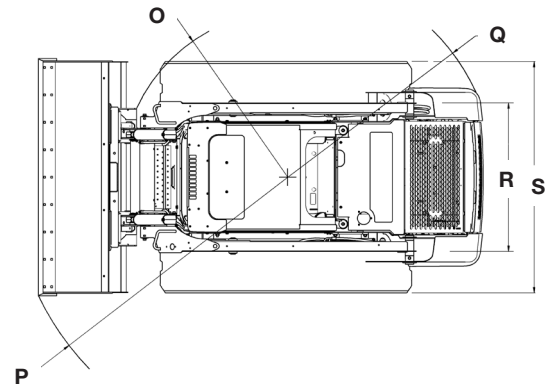
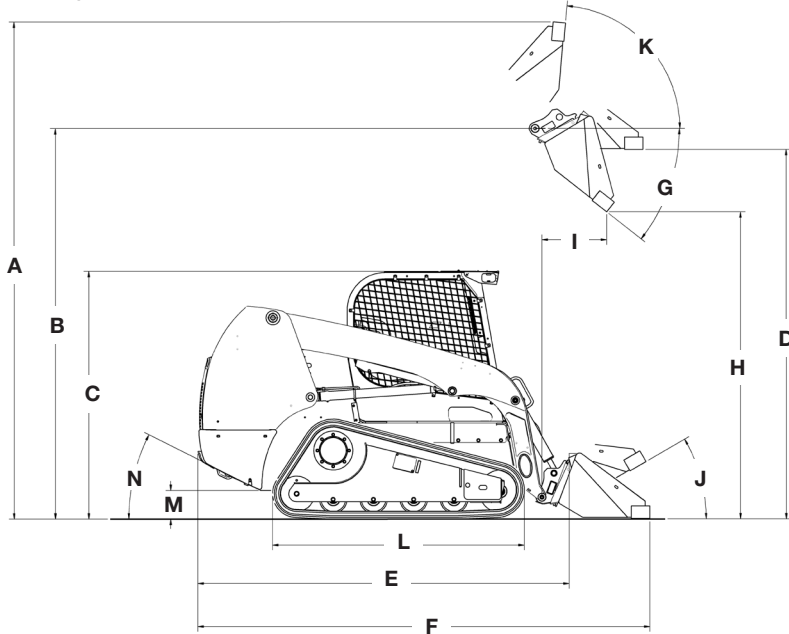

Line drawings are for illustrative purpose only and may not be exact representation of unit.

DIMENSIONS

A. Overall operating height:	
with foundry/excavating bucket	157.8 in (4.01 m)
with heavy-duty dirt bucket	161.8 in (4.11 m)
with low profile extended bucket	166.8 in (4.24 m)
Height to:	
B. Bucket hinge pin	126.5 in (3.22 m)
C. Top of ROPS	80.4 in (2.04 m)
D. Bottom of level bucket, fully raised	119.6 in (3.04 m)
Overall length:	
E. without attachment with coupler	118.7 in (2.98 m)
F. with foundry/excavating bucket on ground	143.5 in (3.64 m)
with heavy-duty bucket	143.7 in (3.64 m)
with low profile extended bucket	152.7 in (3.84 m)
G. Maximum dump angle	38.1°
H. Dump height:	
with foundry/excavating bucket	102.1 in (2.60 m) @ 38.1°
with low profile bucket	99.9 in (2.54 m) @ 38.1°
I. Dump reach at maximum height with heavy-duty bucket	24.7 in (0.63 m) @ 38.1°
Maximum attachment rollback:	
J. Bucket on ground	29.7°
K. Bucket at full height	99.7°
L. Track on ground	64.5 in (1.64 m)
M. Ground clearance – bottom of belly pan	9.5 in (0.24 m)
N. Angle of departure	32.0°
Clearance circle:	
O. without bucket	57.7 in (1.40 m)
P. with 72 in (1.83 m) foundry/excavating bucket in carry position	87.0 in (2.17 m)
with 72 in (1.83 m) heavy-duty bucket on ground	90.8 in (2.25 m)
with 72 in (1.83 m) extended low profile on ground	95.2 in (2.36 m)
Q. Clearance circle rear	71.2 in (1.79 m)
R. Track gauge	58.3 in (1.48 m)
S. Over the track width	76.0 in (1.93 m)

TRACK SELECTION

Type	Area	Ground Pressure	Width to Outside Track
17.7 in (450 mm)	2,286 in ² (1.475 m ²)	4.2 psi (29 kPa)	76 in (1.93 m)

OPTIONAL BUCKETS

Type	Width	Weight	Heaped Capacity
Dirt & Foundry	78 in (1.98 m)	440 lb (200 kg)	17.7 ft ³ (0.50 m ³)
Low Profile Extended	78 in (1.98 m)	540 lb (245 kg)	19.1 ft ³ (0.54 m ³)
	84 in (2.13 m)	575 lb (262 kg)	20.5 ft ³ (0.58 m ³)
Light Material	84 in (2.13 m)	540 lb (245 kg)	27.5 ft ³ (0.78 m ³)
Manure & Slurry	84 in (2.13 m)	545 lb (248 kg)	22.6 ft ³ (0.64 m ³)
Heavy-Duty	78 in (1.98 m)	530 lb (240 kg)	15.5 ft ³ (0.44 m ³)
	84 in (2.13 m)	550 lb (250 kg)	17.0 ft ³ (0.48 m ³)
Heavy-Duty with spillguard	78 in (1.98 m)	605 lb (275 kg)	19.8 ft ³ (0.56 m ³)
	84 in (2.13 m)	640 lb (290 kg)	21.5 ft ³ (0.61 m ³)

STANDARD EQUIPMENT

OPERATOR ENVIRONMENT

See page 1

ENGINE

FPT F5H FL463 A*F001
207 CID (3.4 L) Turbo
Tier 4 Final Certified
Selective Catalytic Reduction (SCR)
Charged Air Cooler (CAC)
High Pressure Common Rail (HPCR)
fuel injection
Horsepower:
Gross: 90 hp (67 kW)
Net: 84 hp (63 kW)
Peak torque: 282 lb-ft (383 N·m)
160 amp alternator
Dual element air cleaner
Organic Acid Technology (OAT)
Anti-freeze solution to -34° F
Fuel tank - 25.5 gal (U.S.)
Over and under radiator and oil cooler
3-stack after cooler/radiator/oil
cooler configuration
Glow plugs
Integral engine oil cooler
Fuel filter with water trap
1,000 CCA 12V battery
Master electrical disconnect
Jump Start Terminal

DRIVETRAIN

2-speed hydrostatic four wheel drive
SAHR disc parking brake

HYDRAULICS

Auxiliary hydraulics:
@ 3,050 psi (210 bar) – 24.2 gpm
(91.5 L/min)
6 micron oil filtration system
3-spool loader control valve
Auxiliary hydraulic disconnects, ISO
flat-face – connect-under-pressure
with case drain
Hydraulic circuit pedal lock
Auxiliary function lockout override
Loader lift lockout override
Heavy-duty hydraulic oil cooler
Loader arm float position
Loader function lockout system

LOADER

Heavy Duty Hydraulic attachment coupler
Radial lift geometry
Loader lift arm support strut
SAE operating load: 3,400 lbs
Tipping load: 6,800 lbs

TRACKS

HiQual S-Wave Tracks

OTHER STANDARD FEATURES

Halogen lights - 2 front, 2 side, 2 rear flood
Heavy duty front lights
Pre-wired for rotating beacon
Lockable service access hood
Single-point daily servicing
Rear tail lights
Remote oil drain
Remote oil and fuel filters
Block heater
Debris ingress sealing
Mounting points for add-on counterweights
Heavy duty rear door

OPTIONAL EQUIPMENT

OPERATOR ENVIRONMENT

ROPS/FOPS Level 1 canopy
with side screens
Keyed start ignition
Ventilation system with integrated heater
Electro-hydraulic controls:
For drive/steering, loader functions
Switchable between H and ISO patterns
Adjustable sensitivity of controls
Mechanical hand controls
Hand and foot controls:
Hand controls the loader drive function
and foot controls the bucket and boom
Non suspension seat
Suspension seat, vinyl
Open cab interior trim package
Demolition cab door with polycarbonate
FOPS Level 2
Heavy duty rear door

HYDRAULICS

High-flow auxiliary hydraulics – combined:
@ 3,050 psi (210 bar) – 37.6 gpm
(142.5 L/min)
Enhanced High-flow auxiliary hydraulics – EHF:
@ 4,000 psi (276 bar) – 35.0 gpm
(132.5 L/min)
Second auxiliary hydraulics
Hydraulic one-way self-leveling
Ride control

LOADER

Auxiliary front electric control
Manual attachment coupler

OTHER

Language decals
Factory-installed tires – see page 3
Buckets – see page 3
Bolt-on bucket cutting edges
Bolt-on heavy-duty bucket spill guard
Special paint
Offsite service arrangement
Telematics

FACTORY SUPPLIED ATTACHMENTS

Add-on counterweights
Road lights
Rotating beacon
Four-corner LED strobe
Bolt-on heavy-duty bucket teeth
48 in (1.22 m) pallet forks

SERVICE PARTS

3 inch (76.2 mm) retractable seat belt

CaseCE.com

©2019 CNH Industrial America LLC. All rights reserved. CASE is a trademark registered in the United States and many other countries, owned by or licensed to CNH Industrial N.V., its subsidiaries or affiliates. CNH Industrial Capital is a trademark in the United States and many other countries, owned by or licensed to CNH Industrial N.V., its subsidiaries or affiliates. Printed in U.S.A. Contains 10% post-consumer fiber.

IMPORTANT: CASE Construction Equipment Inc. reserves the right to change these specifications without notice and without incurring any obligation relating to such change. Availability of some models and equipment builds vary according to the country in which the equipment is used. The illustrations and text may include optional equipment and accessories and may not include all standard equipment. Your CASE dealer/distributor will be able to give you details of the products and their specifications available in your area.



CASE Construction Equipment is biodiesel-friendly. NOTE: All engines meet current EPA emissions regulations. All specifications are stated in accordance with SAE Standards or Recommended Practices, where applicable.



Always read the Operator's Manual before operating any equipment. Inspect equipment before using it, and be sure it is operating properly. Follow the product safety signs and use any safety features provided.

Form No. CCE201910TR340
Replaces Form No. CCE201812TR340

TR340

4 of 4