



ENGINE

Model	FPT F4HFE6132
Emissions Certification	Tier 4 Final Certified
Cylinders	6
Displacement	409 in ³ (6.7 L)
Fuel injection	Common rail
Fuel	#2 Diesel
Fuel filter	Spin-on w/ in-line strainer
Air intake	Cross-flow
Cooling	Liquid
Engine speeds	RPM
High idle - no load	2200 +/- 50
Rated - full load	2200
Low idle	800 +/- 25
Horsepower @ 2000 RPM – SAE J1349:	
Net	150 hp (112 kW)
Gross	164 hp (122 kW)
Engine lubrication:	
Pump	Deep sump plate cooler w/ pressurized under-piston nozzles
Pump operating angle ratings:	
Side-to-side	35°
Fore and aft	45°
Oil filtration	Replaceable, spin-on full-flow cartridge
Radiator:	
Fins per inch	10
Fan:	
Type	Variable speed/ Auto reversing/Hydraulic driven
Diameter	27.6 in (700 mm)

DRIVETRAIN

Dual path hydrostatic:	
Pump	Variable axial piston
Motor	Variable bent axis piston
Max. drawbar pull	61,200 lb (272.2 kN)
Transmission	Single lever control – electronic straight tracking
Transmission oil filter	4-micron at beta 75, replaceable w/ 100 mesh suction screen
Travel speeds:	
Forward	5.8 mph (9.3 kph)
Reverse	5.8 mph (9.3 kph)
Parking brakes	Heavy-duty, spring-applied, hydraulic pressure release disc
Steering brakes	Hydrostatic
Final drive	2 helical gear reduction to planetary output
Ratio	61.4:1
Transmission cooling:	
Type	Oil to air
Core size	515.1 in ² (0.33 m ²)

ELECTRICAL

Alternator	120 amp
Battery	(2) 12-volt, low-maintenance 925 cold-cranking amps @ 0° F (-18° C)
Electrical System	24 Volts

OPERATOR ENVIRONMENT

Fully enclosed ROPS cab; Single lever control for speed, steering and direction; Cloth air suspension seat w/ back adjustment; Retractable 3 in (76 mm) seat belt; Adjustable armrest; Two foot rest; Rearview mirror; Two door windshield wipers; Dome light; 12-volt accessory outlet; Headliner; Floor mat; Rear Wiper; Radio; Heat/AC.

Warning lights:
Air filter; Alternator; Diagnostic fault indicator; Engine coolant temperature; Engine oil pressure; Hydraulic filter; Low fuel level; DEF fluid level; Park brake engaged; Service soon indicator; Transmission filter; Transmission charge pressure.

Gauges:
Battery voltage; Fuel level; Digital hour meter/tachometer/diagnostic/service reminder; Transmission oil temperature; Transmission speed indicator; Water temperature; Diesel Exhaust Fluid (DEF) level.

Audible warnings:
Engine coolant temperature; Engine oil pressure; Low fuel level; Transmission charge pressure; Temperature/hydraulic temperature.

OPERATING WEIGHT

Unit equipped w/ cab, full fuel tank, 170 lb (77 kg) operator, front pull hook, rear retrieval hitch, track guides, PAT blade.	
Extra Long Track	37,756 lb (17 123 kg)
Wide Track	38,657 lb (17 531 kg)
LGP	39,557 lb (17 940 kg)
Add-on weights:	
Drawbar	3,857 lb (1 749 kg)
Ripper - 3 shank	2,988 lb (1 355 kg)
Winch	2,331 lb (1 087 kg)
SALT chain:	
22 in (559 mm)	222.7 lb (101 kg)
24 in (610 mm)	220.5 lb (100 kg)
28 in (711 mm)	222.7 lb (101 kg)
32 in (813 mm)	222.7 lb (101 kg)
34 in (864 mm)	227.1 lb (103 kg)
Center rock guard	417 lb (189 kg)
Sweeps	139 lb (63 kg)

HYDRAULICS

Pump flow @ 2200 RPM @ 2,830 psi (19 512 kPA)	34.9 gpm (132 L/min)
Lift cylinder w/ PAT	Two (2)
Bore diameter	4.50 in (114.3 mm)
Rod diameter	2.50 in (63.5 mm)
Stroke	16.88 in (428.8 mm)
Angle cylinder w/ PAT	Two (2)
Bore diameter	4.50 in (114.3 mm)
Rod diameter	2.50 in (63.5 mm)
Stroke	19.79 in (502.7 mm)
Tilt cylinder w/ PAT	One (1)
Bore diameter	5.00 in (127.0 mm)
Rod diameter	2.50 in (63.5 mm)
Stroke	5.84 in (148.4 mm)
Lift cylinder – Bulldozer	Two (2)
Bore diameter	3.8 in (95.3 mm)
Rod diameter	2.25 in (57.2 mm)
Stroke	35.67 in (906.0 mm)
Tilt cylinder – Bulldozer	One (1)
Bore diameter	4.50 in (114.3 mm)
Rod diameter	2.50 in (63.5 mm)
Stroke	3.89 in (98.9 mm)

SERVICE CAPACITIES

Fuel tank	85.0 gal (322.0 L)
Engine oil w/ filter	17.3 qt (16.4 L)
Engine oil w/o filter	16.5 qt (15.6 L)
Engine cooling system	8.0 gal (30.28 L)
Hydraulic reservoir	42.0 gal (160.0 L)
Final drive – per side	16.4 qt (15.6 L)
Track rollers – each	0.264 qt (0.250 L)
Front idlers – each	0.349 qt (0.330 L)
Carrier rollers – each	0.285 qt (0.270 L)
DEF tank	14.0 gal (52.0 L)

OTHER SPECIFICATIONS

Undercarriage:	
Track adjustment	Hydraulic
Frame	Pivot shaft and oscillating equalizer beam suspension
Length of Track on the ground:	
SALT HD	121.5 in (3 087 mm)
ULTRA Life	121.5 in (3 087 mm)
Track link pitch	7.5 in (190 mm)
Track shoe height	2.19 in (56 mm)
Pin diameter	1.5 in (38 mm)
Bushing diameter:	
SALT HD track	2.56 in (65 mm)
Ultra Life track	2.56 in (65 mm)
Track shoes per side	45
Track rollers per side	8
Carrier rollers per side	2
Track roller rail diameter	7.99 in (203 mm)

Track on ground:	
Shoe area:	
22 in (559 mm)	5,349 in ² (34 509 cm ²)
24 in (610 mm)	5,837 in ² (37 657 cm ²)
28 in (711 mm)	6,803 in ² (43 893 cm ²)
32 in (813 mm)	7,779 in ² (50 190 cm ²)
34 in (864 mm)	8,267 in ² (53 338 cm ²)

Track:	
Extra long track:	
22 in (559 mm)	closed grousers and SALT HD
22 in (559 mm)	open grousers and Ultra Life
24 in (610 mm)	closed grousers and SALT HD
24 in (610 mm)	open grousers and Ultra Life
Wide track:	
28 in (711 mm)	closed grousers and SALT HD
28 in (711 mm)	open grousers and Ultra Life
32 in (813 mm)	closed grousers and SALT HD
32 in (813 mm)	open grousers and Ultra Life
Low ground pressure:	
34 in (864 mm)	closed grousers and SALT HD
34 in (864 mm)	open grousers and Ultra Life

Blade:	
Variable blade pitch	55° – 60°
Lift speed – per second	19.0 in (483 mm)
Cutting edge	Reversible, replaceable
Width	7.9 in (200 mm)
Thickness	0.8 in (20 mm)

Ripper:	
Max. penetration	21.5 in (546 mm)
Width	76.9 in (1 953 mm)
Cut width	74.4 in (1 890 mm)
Max. ground clearance	24.1 in (611 mm)
Max. number of shanks	3
Tooth spacing:	
w/ 3 teeth	37.2 in (945 mm)
Hydraulic cylinder	
Diameter	Double-acting
Stroke	6.14 in (156 mm)
Rod	23.5 in (597 mm)
	2.75 in (70 mm)

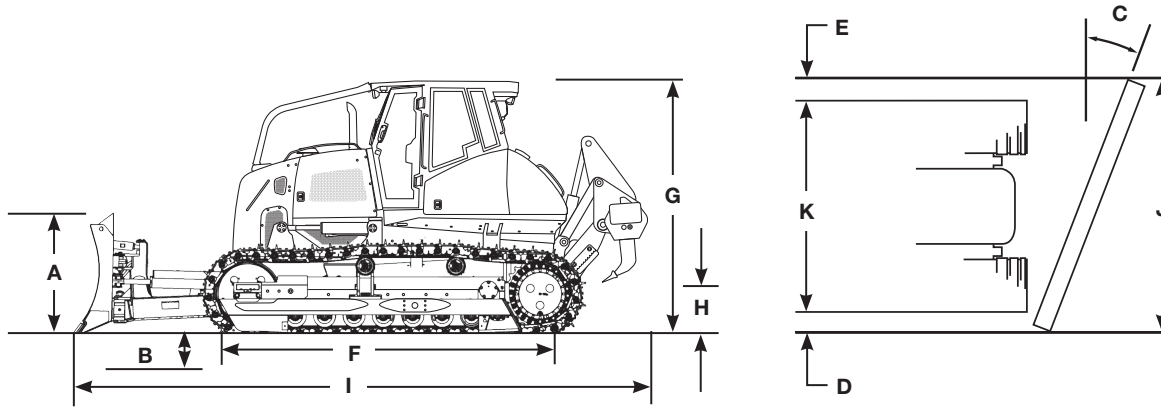

Line drawings are for illustrative purpose only and may not be exact representation of unit.

DIMENSIONS

	Extra Long Track (XLT) with Semi U	Extra Long Track (XLT) with PAT	Wide Track (WT) with PAT	Low Ground Pressure (LGP) with PAT
Blade width	131 in (3 322 mm)	130 in (3 302 mm)	156 in (3 962 mm)	156 in (3 962 mm)
SAE blade capacity	6.33 yd ³ (4.84 m ³)	4.28 yd ³ (3.18 m ³)	5.28 yd ³ (4.04 m ³)	5.28 yd ³ (4.04 m ³)
A. Blade height	51.9 in (1 319 mm)	46.3 in (1 176 mm)	46.3 in (1 176 mm)	46.3 in (1 176 mm)
Blade lift above ground	44.3 in (1 124 mm)	42.5 in (1 077 mm)	42.5 in (1 077 mm)	42.5 in (1 077 mm)
B. Blade depth below ground	22.5 in (572 mm)	19.8 in (503 mm)	19.8 in (503 mm)	19.8 in (503 mm)
C. Blade angle both directions	0° +/-	25°	25°	25°
D. Cast reach	16.3 in (414 mm)	17.2 in (457 mm)	20.0 in (507 mm)	19.2 in (487 mm)
E. Cut reach	16.3 in (414 mm)	0.9 in (24 mm)	3.9 in (99 mm)	3.0 in (76 mm)
Blade tilt, each end – up to 8.3°	16.1 in (410 mm)	17.7 in (450 mm)	21.7 in (550 mm)	21.7 in (550 mm)
Track gauge	76 in (1.93 m)	76 in (1.93 m)	86 in (2.18 m)	86 in (2.18 m)
Maximum shoe width	24 in (606 mm)	24 in (610 mm)	32 in (813 mm)	34 in (864 mm)
F. Length of track on ground	121.7 in (3.09 m)	121.7 in (3.09 m)	121.7 in (3.09 m)	121.7 in (3.09 m)
Area of track on ground	5,837 in ² (3.77 m ²)	5,837 in ² (3.77 m ²)	7,770 in ² (5.01 m ²)	8,268 in ² (5.01 m ²)
Ground pressure	6.62 psi (0.46 bar)	6.62 psi (0.46 bar)	5.27 psi (0.36 bar)	4.78 psi (0.33 bar)
G. Height to top of ROPS cab	9 ft 8 in (2 945 mm)	9 ft 8 in (2 945 mm)	9 ft 8 in (2 945 mm)	9 ft 8 in (2 945 mm)
H. Ground clearance	13.5 in (342 mm)	13.5 in (342 mm)	13.5 in (342 mm)	13.5 in (342 mm)
Length:				
Blade straight with drawbar	19 ft 8 in (5 985 mm)	18 ft 8 in (5 678 mm)	18 ft 8 in (5 678 mm)	18 ft 8 in (5 678 mm)
I. Blade straight with ripper	24 ft 1 in (7 345 mm)	23 ft 1 in (7 038 mm)	23 ft 1 in (7 038 mm)	23 ft 1 in (7 038 mm)
Width:				
Blade straight	10 ft 11 in (3 322 mm)	10 ft 10 in (3 302 mm)	13 ft 0 in (3 962 mm)	13 ft 0 in (3 962 mm)
J. Blade angled	—	9 ft 10 in (3 000 mm)	11 ft 10 in (3 602 mm)	11 ft 10 in (3 602 mm)
K. Over track	8 ft 2 in (2 490 mm)	8 ft 4 in (2 530 mm)	9 ft 10 in (2 994 mm)	8 ft 2 in (2 490 mm)

NOTE: Ground clearance and overall height dimensions are with the grousers fully penetrated. Add 2.19 in (56 mm) if unit is on solid surface.

STANDARD EQUIPMENT

OPERATOR ENVIRONMENT

See page 1

ENGINE

F4HFE6132
Tier 4 Final Certified
V-Shape Cooling package with hydraulic-driven reversing fan
Integral engine oil cooling
Fuel filter
Dual element radial seal air cleaner
120 amp alternator
(2) 925 CCA 12-volt batteries
Coolant Heated DEF Lines
Hinged engine side panels

DRIVETRAIN

Dual path infinitely variable, single-lever controlled hydrostatic drive, with electronic straight tracking and counter-rotation
Final drive:
Triple reduction; helical gear/planetary decelerator with hydrostatic drive retardation
Automatic spring-applied parking brake

BLADE

55° – 60° variable pitch, with integral adjustment tool
Single lever electro-hydraulic control for blade lift, angle and tilt

UNDERCARRIAGE

Hydraulic track adjusters
Sealed and Lubricated Track Chain (SALT)
Permanently lubricated track and carrier rollers and idlers
Track adjuster guard
Track guides – front and rear
Robust Smooth One Piece Track Frames with Easy Clean-out
Enhanced Track Recoil System
Central Grease point for Pivot Shaft and Equalizer Beam

OTHER

Backup alarm
Horn
Work lights:
2 front
1 rear
Master disconnect switch
Mirror
Turbine Pre-cleaner
Front pull hook
Rear tow hook
Environmental Drain
Grid Heater/Cold Start
Transport Protection
Anti-vandalism package
Rear transmission guard

TELEMATICS

CASE SiteWatch™ Telematics – includes hardware and a 3-yr Advanced data subscription

PROCARE

CASE ProCare – Full Machine Protection Factory Warranty (3-yr/3000-hr), Planned Maintenance (3-yr/2000-hr) and SiteWatch telematics

OPTIONAL EQUIPMENT

OPERATOR ENVIRONMENT

Cab air quality system

HYDRAULICS

4-spool hydraulic valve for field-installed ripper
3-spool hydraulic valve without plugs for field-installed ripper
3-spool hydraulic valve with plugs

REAR MOUNTED EQUIPMENT

Ripper – 3 position with 3 shanks
HD Ripper - 6" Tooth
Drawbar
Drawbar with step

BLADES

PAT – 130 in (3 302 mm)
PAT – 156 in (3 974 mm)
Foldable PAT – 156 in (3 974 mm)
Semi-U – 131 in (3 322 mm)

GUARDS

CAB canopy brush guard
Center rock guard
Sweeps
Waste Handler Guarding Package

SCREENS

Cab rear screen

OTHER

CASE Ultra Life Track
Additional work lights
Severe Cold Weather Package

PRECISION

Factory Fit CoPilot
Factory Fit 2D Laser
Factory Fit 3D GNSS
Universal Blade Guidance:
Compatible with Leica, Trimble and Topcon
Leica Blade Guidance Ready
Trimble Blade Guidance Ready
Topcon Blade Guidance Ready

CaseCE.com

©2021 CNH Industrial America LLC. All rights reserved. CASE is a trademark registered in the United States and many other countries, owned by or licensed to CNH Industrial N.V., its subsidiaries or affiliates. CNH Industrial Capital is a trademark in the United States and many other countries, owned by or licensed to CNH Industrial N.V., its subsidiaries or affiliates. Printed in U.S.A. Contains 10% post-consumer fiber.

IMPORTANT: CASE Construction Equipment Inc. reserves the right to change these specifications without notice and without incurring any obligation relating to such change. Availability of some models and equipment builds vary according to the country in which the equipment is used. The illustrations and text may include optional equipment and accessories and may not include all standard equipment. Your CASE dealer/distributor will be able to give you details of the products and their specifications available in your area.



CASE Construction Equipment is biodiesel-friendly. NOTE: All engines meet current EPA emissions regulations. All specifications are stated in accordance with SAE Standards or Recommended Practices, where applicable.



Always read the Operator's Manual before operating any equipment. Inspect equipment before using it, and be sure it is operating properly. Follow the product safety signs and use any safety features provided.

Form No. CCE2021021650M
Replaces Form No. CCE2019121650M

1650M

3 of 3