



## ENGINE

Model	Isuzu AR-4JJ1X CEGR, SCR, DOC
Emissions Certification	Tier 4 Final
Fuel	Requires ultra-low sulfur fuel B5 biodiesel tolerant
Type	Water-cooled, 4-cycle, high pressure common rail system Turbocharger w/ air cooled intercooler, SCR system
Cylinders	4-cylinder in-line
Displacement	183 in <sup>3</sup> (3 L)
Bore/Stroke	3.76 x 4.13 in (95.4 x 104.9 mm)
Fuel injection	Direct injection – electronic
Fuel filter	Replaceable, full flow spin-on cartridge
Air filter	Dry type element w/ warning restriction indicator
Oil filter	Replaceable, full flow spin-on cartridge
Engine gradeability:	
Side-to-side	35°
Fore and aft	35°
Net horsepower – SAE J1349 @ 2200 RPM:	112 hp (83.2 kW)
Gross horsepower – ISO 14396 @ 2200 RPM:	115 hp (86.0 kW)
Net max. torque – SAE J1349 @ 1800 RPM:	257 lbf-ft (349 N·m)
Cooling operating range:	109° to -13°F (43° to -25°C)
Oil	Requires low-ash oil CJ-4

## DRIVETRAIN

Travel control	Dual stage relief/ counter balance design
Brakes	Mechanical disc
Service brakes	SAHR disc – each motor
Two speed travel:	
Max. high speed	3.4 mph (5.4 km/h)
Max. low speed	1.7 mph (2.8 km/h)
Automatic downshift	
Drawbar pull	36,100 lbf (160 kN)
Gradeability	70% – 35° Slope

## ELECTRICAL

Voltage	24 Volts
Alternator rating	50 amp
Batteries	2 x 12 Volt
Battery reserve capacity	72 Ah/5 hour
Work lights – 4 1 boom, 1 upper, 2 cab	24 Volt/70 watt

## OPERATOR ENVIRONMENT

Air conditioner output	18,100 BTU/hr
Heater output	20,150 BTU/hr
Sound level inside cab – ISO6395	70 dBA
Electrical outlet	12 Volt
Cab interior light	10 watt
Rear view camera	Standard
Seat	Heated, air-suspension

## ATTACHMENT

Boom	16 ft 11 in (5 150 mm)
Arm options	8 ft 7 in (2.62 m) 10 ft 0 in (3.05 m)
Bucket digging force* w/ auto power up	25,200 lbf (112 kN) 26,500 lbf (118 kN)

NOTE: \*Digging force ratings based on ISO6015.

## OPERATING WEIGHT

Operating weight	38,400 lb (17 400 kg)
w/ shoes	2 ft 0 in (600 mm)
w/ boom	16 ft 11 in (5 150 mm)
w/ arm	8 ft 7 in (2.62 m)
w/ bucket	1,067 lb (484 kg)
w/ counterweight	6,980 lb (3 170 kg)

NOTE: W/ operator/full fuel/standard equipment.

## GROUND PRESSURE

@ Standard operating weight	5.9 psi (0.41 bar)
w/ 23.6 in (600 mm) triple grouser shoes	

## HYDRAULICS

System design	Open center
Main pumps	Two-variable displacement/ axial piston
Max. rated flow per pump:	
	37.5 gpm (142 L/min)
Max rated flow total:	
	75.02 gpm (284 L/min)
System pressures:	
Boom, arm and bucket	4,970 psi (343 bar)
w/ Power Boost	5,260 psi (363 bar)
Travel circuits	4,970 psi (343 bar)
Swing circuits	4,050 psi (279 bar)
Pilot pump	1 x gear design
Max. capacity	5.8 gpm (22 L/min)

Controls	w/ boom/arm holding valve
Right track travel, bucket, boom and arm acceleration.	1 x Four-spool section
Left track travel, auxiliary, swing, boom and arm acceleration.	1 x Five-spool section

Work mode selections	SP: Speed Priority H: Heavy-Duty A: Automatic
----------------------	-----------------------------------------------------

Swing motor	Fixed displacement axial piston
Swing final drive	Planetary gear reduction
Travel motor	Two-speed independent travel/axial piston

## HYDRAULIC CYLINDERS

Boom cylinders	Two (2)
Cylinder bore	4.5 in (115 mm)
Cylinder rod diameter	3.1 in (80 mm)
Cylinder stroke	46.4 in (1 179 mm)
Arm cylinder	One (1)
Cylinder bore	4.9 in (125 mm)
Cylinder rod diameter	3.5 in (90 mm)
Cylinder stroke	50.4 in (1 280 mm)
Bucket cylinder	One (1)
Cylinder bore	4.1 in (105 mm)
Cylinder rod diameter	3.0 in (75 mm)
Cylinder stroke	38.8 in (985 mm)

## SERVICE CAPACITIES

Fuel tank	79 gal (300 L)
Hydraulic system	44 gal (167 L)
Hydraulic tank	22 gal (82 L)
Engine oil w/ filter	4.5 gal (17 L)
Swing drive	1.3 gal (5 L)
Final drive	1.5 gal (5.8 L)
Cooling system	4.7 gal (17.8 L)
DEF tank	22 gal (85 L)

## OTHER SPECIFICATIONS

Swing speed	11.5 RPM
Swing torque	33,300 lbf-ft (45 100 kN·m)
Swing brake	Mechanical disc
Undercarriage:	
Length	13 ft 1 in (3 990 mm)
Track gauge	6 ft 6 in (1 990 mm)
Carrier rollers – each side	2
Track rollers – each side	7
Shoes – triple grouser – each side	44
Shoe width – std.	2 ft 0 in (600 mm)
Link pitch	8 in (190 mm)
Track:	
Chain	Grease lubricated/strutted
Guides	Single
Adjustment	Hydraulic

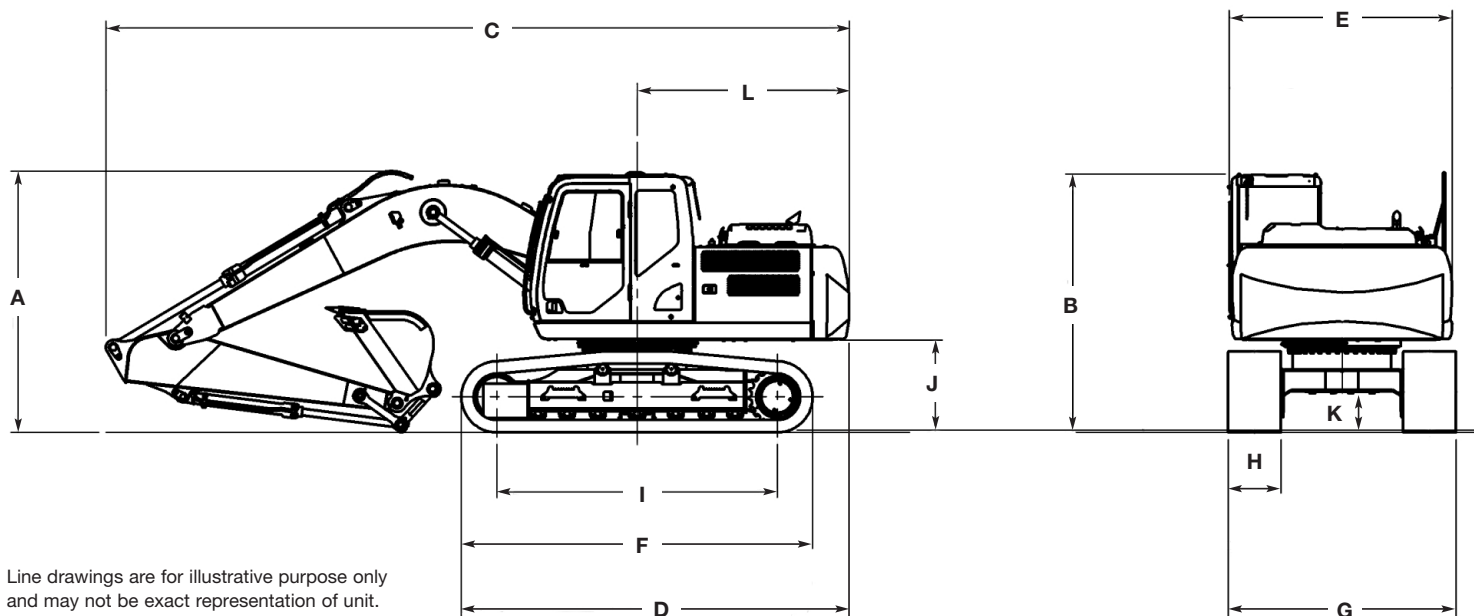

## DIMENSIONS

	8 ft 7 in (2.62 m) Arm	10 ft 0 in (3.04 m) Arm
<b>A.</b> Overall height	9 ft 9 in (2 960 mm)	10 ft 3 in (3 130 mm)
<b>B.</b> Cab height	9 ft 9 in (2 970 mm)	9 ft 9 in (2 970 mm)
<b>C.</b> Overall length – with attachment	27 ft 9 in (8 460 mm)	27 ft 11 in (8 520 mm)
<b>D.</b> Overall length – without attachment	14 ft 6 in (4 430 mm)	14 ft 6 in (4 430 mm)
<b>E.</b> Width of upper structure	8 ft 4 in (2 530 mm)	8 ft 4 in (2 530 mm)
<b>F.</b> Track overall length	13 ft 1 in (3 990 mm)	13 ft 1 in (3 990 mm)
<b>G.</b> Track overall width with 23.6 in (600 mm) shoes	8 ft 6 in (2 590 mm)	8 ft 6 in (2 590 mm)
<b>H.</b> Track shoe width	2 ft 0 in (600 mm)	2 ft 0 in (600 mm)
<b>I.</b> Center to center – idler to sprocket	10 ft 6 in (3 190 mm)	10 ft 6 in (3 190 mm)
<b>J.</b> Upper structure ground clearance	3 ft 4 in (1 020 mm)	3 ft 4 in (1 020 mm)
<b>K.</b> Minimum ground clearance	1 ft 5 in (420 mm)	1 ft 5 in (420 mm)
<b>L.</b> Rear tail swing radius	8 ft 1 in (2 470 mm)	8 ft 1 in (2 470 mm)

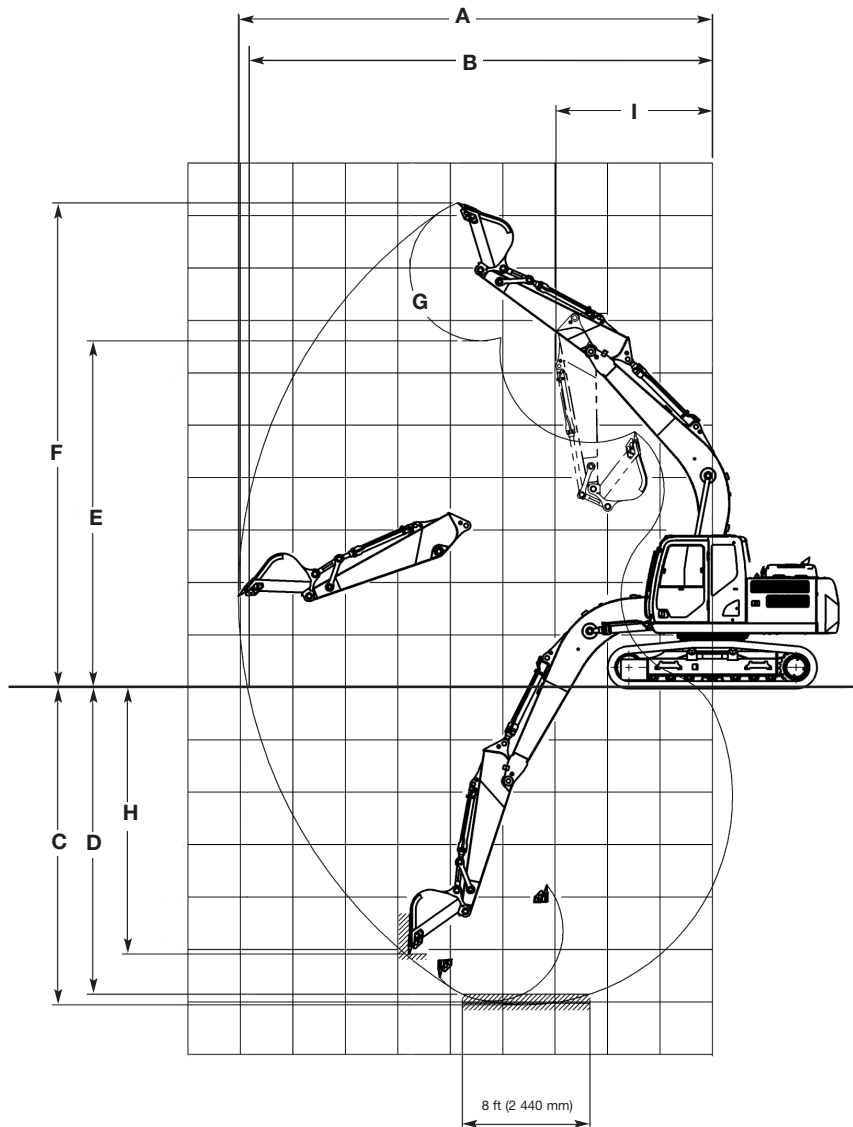

### PERFORMANCE SPECS

	8 ft 7 in (2.62 m) Arm	10 ft 0 in (3.04 m) Arm
A. Maximum dig radius	29 ft 8 in (9 040 mm)	30 ft 9 in (9 380 mm)
B. Dig radius at groundline	29 ft 1 in (8 870 mm)	30 ft 3 in (9 220 mm)
C. Maximum dig depth	19 ft 11 in (6 060 mm)	21 ft 4 in (6 490 mm)
D. Dig depth – 8 ft 0 in (2.44 m) level bottom	19 ft 3 in (5 860 mm)	20 ft 8 in (6 290 mm)
E. Dump height	21 ft 8 in (6 610 mm)	21 ft 11 in (6 690 mm)
F. Maximum reach height	30 ft 4 in (9 240 mm)	30 ft 6 in (9 290 mm)
G. Bucket rotation	178°	178°
H. Maximum vertical wall dig depth	16 ft 8 in (5 080 mm)	17 ft 2 in (5 220 mm)
I. Minimum swing radius	9 ft 10 in (2 990 mm)	10 ft 0 in (3 050 mm)
Arm digging force:		
Standard	17,800 lbf (79 kN)	16,200 lbf (72 kN)
Power Boost	18,800 lbf (84 kN)	17,300 lbf (77 kN)
Bucket digging force:		
Standard	25,200 lbf (112 kN)	25,200 lbf (112 kN)
Power Boost	26,500 lbf (118 kN)	26,500 lbf (118 kN)

**LIFT CAPACITIES**

**8 ft 7 in (2.62 m) Arm** Lift capacities calculated using a 1,050 lb (476 kg) bucket, 6,943 lb (3 150 kg) counterweight.

Load (Lift Point Height)	5 ft (1.5 m)		10 ft (3 m)		15 ft (4.5 m)		20 ft (6 m)		25 ft (7.5 m)		MAXIMUM REACH		
	END	SIDE	END	SIDE	END	SIDE	END	SIDE	END	SIDE	@	END	SIDE
+25 ft (7.5 m)							5,150 lb (2 336 kg)	5,150 lb (2 336 kg)			21 ft 0 in (6.40 m)	3,650 lb (1 656 kg)	3,650 lb (1 656 kg)
+20 ft (6 m)							7,100 lb (3 221 kg)	7,100 lb (3 221 kg)			25 ft 0 in (7.62 m)	3,300 lb (1 497 kg)	3,300 lb (1 497 kg)
+15 ft (4.5 m)							9,200 lb (4 173 kg)	7,000 lb (3 175 kg)	6,750 lb (3 062 kg)	4,650 lb (2 109 kg)	27 ft 4 in (8.33 m)	3,200 lb (1 451 kg)	3,200 lb (1 451 kg)
+10 ft (3 m)			18,500 lb (8 391 kg)	18,500 lb (8 391 kg)	13,350 lb (6 055 kg)	10,450 lb (4 740 kg)	10,400 lb (4 717 kg)	6,600 lb (2 994 kg)	7,150 lb (3 243 kg)	4,500 lb (2 041 kg)	28 ft 5 in (8.66 m)	3,250 lb (1 474 kg)	3,250 lb (1 474 kg)
+5 ft (1.5 m)			21,350 lb (9 684 kg)	17,600 lb (7 983 kg)	15,900 lb (7 212 kg)	9,600 lb (4 354 kg)	9,950 lb (4 513 kg)	6,150 lb (2 790 kg)	6,950 lb (3 152 kg)	4,250 lb (1 928 kg)	28 ft 7 in (8.71 m)	3,450 lb (1 565 kg)	3,350 lb (1 520 kg)
Groundline			17,200 lb (7 802 kg)	16,250 lb (7 371 kg)	15,150 lb (6 872 kg)	8,950 lb (4 060 kg)	9,550 lb (4 332 kg)	5,800 lb (2 631 kg)	6,750 lb (3 062 kg)	4,100 lb (1 860 kg)	27 ft 8 in (8.43 m)	3,850 lb (1 746 kg)	3,450 lb (1 565 kg)
-5 ft (-1.5 m)	13,450 lb (6 101 kg)	13,450 lb (6 101 kg)	21,950 lb (9 956 kg)	16,450 lb (7 462 kg)	14,850 lb (6 736 kg)	8,700 lb (3 946 kg)	9,400 lb (4 264 kg)	5,650 lb (2 563 kg)	6,700 lb (3 039 kg)	4,050 lb (1 837 kg)	25 ft 10 in (7.87 m)	4,550 lb (2 064 kg)	3,850 lb (1 746 kg)
-10 ft (-3 m)	19,550 lb (8 868 kg)	19,550 lb (8 868 kg)	28,000 lb (12 701 kg)	16,750 lb (7 598 kg)	14,950 lb (6 781 kg)	8,800 lb (3 992 kg)	9,500 lb (4 309 kg)	5,800 lb (2 631 kg)			22 ft 8 in (6.91 m)	6,000 lb (2 722 kg)	4,750 lb (2 155 kg)
-15 ft (-4.5 m)	28,400 lb (12 882 kg)	28,400 lb (12 882 kg)	22,600 lb (10 251 kg)	17,400 lb (7 893 kg)	15,100 lb (6 849 kg)	9,350 lb (4 241 kg)					17 ft 10 in (5.44 m)	10,550 lb (4 785 kg)	7,000 lb (3 175 kg)

**10 ft 0 in (3.04 m) Arm** Lift capacities calculated using a 950 lb (431 kg) bucket, 6,943 lb (3 150 kg) counterweight.

Load (Lift Point Height)	0 ft (0 m)		5 ft (1.5 m)		10 ft (3 m)		15 ft (4.5 m)		20 ft (6 m)		25 ft (7.5 m)		MAXIMUM REACH		
	END	SIDE	END	SIDE	END	SIDE	END	SIDE	END	SIDE	END	SIDE	@	END	SIDE
+25 ft (7.5 m)									4,850 lb (2 200 kg)	4,850 lb (2 200 kg)			22 ft 7 in (6.88 m)	3,400 lb (1 542 kg)	3,400 lb (1 542 kg)
+20 ft (6 m)									6,550 lb (2 971 kg)	6,550 lb (2 971 kg)	4,800 lb (2 177 kg)	4,800 lb (2 177 kg)	26 ft 4 in (8.03 m)	3,100 lb (1 406 kg)	3,100 lb (1 406 kg)
+15 ft (4.5 m)									8,400 lb (3 810 kg)	7,150 lb (3 243 kg)	6,550 lb (2 971 kg)	4,750 lb (2 155 kg)	28 ft 6 in (8.69 m)	3,050 lb (1 383 kg)	3,050 lb (1 383 kg)
+10 ft (3 m)					16,350 lb (7 416 kg)	16,350 lb (7 416 kg)	12,200 lb (5 534 kg)	10,700 lb (4 853 kg)	10,150 lb (4 604 kg)	6,700 lb (3 039 kg)	7,250 lb (3 289 kg)	4,550 lb (2 064 kg)	29 ft 7 in (9.02 m)	3,150 lb (1 429 kg)	3,150 lb (1 429 kg)
+5 ft (1.5 m)					24,150 lb (10 954 kg)	18,150 lb (8 233 kg)	15,900 lb (7 212 kg)	9,750 lb (4 423 kg)	10,050 lb (4 599 kg)	6,250 lb (2 835 kg)	7,000 lb (3 175 kg)	4,300 lb (1 950 kg)	29 ft 8 in (9.04 m)	3,350 lb (1 520 kg)	3,150 lb (1 429 kg)
Groundline			7,250 lb (3 289 kg)	7,250 lb (3 289 kg)	19,350 lb (8 777 kg)	16,550 lb (7 507 kg)	15,200 lb (6 895 kg)	9,000 lb (4 082 kg)	9,600 lb (4 354 kg)	5,850 lb (2 654 kg)	6,750 lb (3 062 kg)	4,100 lb (1 860 kg)	28 ft 10 in (8.79 m)	3,750 lb (1 701 kg)	3,250 lb (1 474 kg)
-5 ft (-1.5 m)	10,300 lb (4 672 kg)	10,300 lb (4 672 kg)	12,700 lb (5 761 kg)	12,700 lb (5 761 kg)	22,000 lb (9 979 kg)	16,250 lb (7 371 kg)	14,800 lb (6 713 kg)	8,650 lb (3 924 kg)	9,350 lb (4 241 kg)	5,650 lb (2 563 kg)	6,650 lb (3 016 kg)	4,000 lb (1 814 kg)	27 ft 1 in (8.26 m)	4,450 lb (2 018 kg)	3,550 lb (1 610 kg)
-10 ft (-3 m)	13,750 lb (6 237 kg)	13,750 lb (6 237 kg)	17,950 lb (8 142 kg)	17,950 lb (8 142 kg)	28,850 lb (13 086 kg)	16,500 lb (7 484 kg)	14,800 lb (6 713 kg)	8,700 lb (3 946 kg)	9,400 lb (4 264 kg)	5,650 lb (2 563 kg)			24 ft 1 in (7.34 m)	5,800 lb (2 631 kg)	4,300 lb (1 950 kg)
-15 ft (-4.5 m)			28,300 lb (12 837 kg)	28,300 lb (12 837 kg)	24,650 lb (11 181 kg)	17,050 lb (7 734 kg)	15,100 lb (6 849 kg)	9,050 lb (4 105 kg)					19 ft 7 in (5.97 m)	9,300 lb (4 218 kg)	6,000 lb (2 722 kg)

NOTE: \*Following number indicates hydraulic capacity

## STANDARD EQUIPMENT

### ENGINE

Isuzu AR-4JJ1X  
Tier 4 Final Certified  
Selective Catalytic Reduction – SCR  
Diesel Oxidation Catalyst – DOC  
Cooled Exhaust Gas Recirculation – CEGR  
EGR Coolers  
Four-cylinder turbo-charged diesel  
VGT turbocharger  
Electronic fuel injection  
High pressure common rail system  
Neutral safety start  
Auto-engine warm up  
Glow-plug pre-heat  
Fuel Economy Assist System – FEA  
Engine Protection Feature – EPF  
Dual-stage fuel filtration  
Dual element air filter  
Remote oil filter  
Drain for fuel tank  
Remote engine oil drain  
500-hour engine oil change interval  
24 Volt system  
Engine oil sample port  
Battery disconnect switch  
Emergency engine stop  
External Fuel and DEF gauges  
Fan housing  
Fuel cooler  
Fuel filter restriction indicator  
Fuel shut-off valve  
Idle start  
Radiator, oil cooler,  
intercooler – protective screen

### FUEL ECONOMY SYSTEMS

Engine Idle/Fuel Economy System:  
Auto-idle  
One-touch idle  
Auto-idle shut-down  
BEC – Boom Economy Control  
AEC – Auto Economy Control  
SWC – Swing Relief Control  
SSC – Spool Stroke Control

### HYDRAULICS

Auto power boost  
Auto swing priority  
Arm speed assistance – 2 pump flow  
Auxiliary flow control  
Auxiliary valve  
Boom speed assistance – 2 pump flow  
Bucket curl assist  
Control levers pre-wired for  
auxiliary hydraulics  
Electronically controlled hydraulic pumps  
Holding valve – Boom and Arm  
Fire wall  
Hydraulic filter restriction indicator  
Neutral pump de-stroke  
Oil cooler

Power save  
Pump stand-by pressure  
Auto travel speed change  
Selectable work modes  
Free swing  
Hydraulic oil sample port  
Control pattern selector  
Pre-set auxiliary pump settings  
Auxiliary valve  
5,000-hour hydraulic oil change interval  
1,000-hour hydraulic filter change interval  
SAHR brake

### UPPER STRUCTURE

ISO mirrors – 3  
Viscous Cab mounts – fluid and spring  
Upper mounted work light – 70 watt  
Swivel guard belly pan  
Center cover – over main CV  
Fuel tank belly pan  
Handrail – RH access  
ISO guard rails  
Lifting eyes for counterweight  
Lockable fuel cap, service doors and tool box

### ATTACHMENTS

Boom – 16 ft 11 in (5.15 m)  
Arm – 8 ft 7 in (2.62 m)  
Heavy-duty bucket linkage  
Boom mounted work light – 70 watt  
Auxiliary pipe brackets  
Centralized grease fittings  
Attachment cushion valve  
Arm and boom regeneration  
Bucket anti-clatter device  
Chrome pins  
Easy Maintenance System (EMS) bushings  
Teardrop pin retention keepers

### OPERATOR ENVIRONMENT

ROPS protection  
FOPS cab top guard – Level 1  
Pressurized cab  
Face vent  
Cab lights – 2  
Interior dome light  
One-touch lock front window  
One piece window – right  
Safety glass windows  
Gate lock hydraulic activation  
Emergency exit and hammer  
Clear polycarbonate roof window  
with sunshade  
AC/heat/defrost with auto climate control  
LED Color monitor – 7 in (180 mm)  
26 selectable languages for monitor  
On-board diagnostic system  
10 programmable attachments settings on  
monitor – 5 single flow, 5 dual flow  
Seatbelt – 3 in (76 mm)  
Heated high-back cloth seat with air  
suspension and 65° tilt adjustment  
Sliding seat – 3.54 in (90 mm)

Adjustable armrests  
Tilting consoles – 4-position  
Sliding cockpit – 3.15 in (80 mm)  
Low-effort joystick controls  
Controls pre-wired for auxiliary  
Straight travel  
AM/FM radio with antenna, 2 speakers and  
Bluetooth capabilities  
Aux-in port for personal electronics  
Radio mute switch – joystick  
Rear-view camera  
Anti-theft system – start code system  
Rubber floor mat  
12 Volt electric outlet  
24 Volt cigarette lighter  
Windshield wiper/washer  
Cup holder  
Storage compartments  
Warm/cool storage compartment  
Travel alarm with cancel switch  
Ignition keys  
One key start & lock-up  
Cab filter – external  
Cab handrails  
Operator's manual

### UNDERCARRIAGE

23.6 in (600 mm) steel shoes,  
triple semi-grouser  
Full overlap turntable bearing tub  
Single track chain guides  
Hydraulic track adjustment  
Sealed link chain  
Steps  
Carbody belly pan – swivel guard  
X-pattern carbody  
Lashing points – tie downs  
Extra Filter Kit:  
Engine oil filter  
Filter wrench  
Fuel filters  
Green plug oil drain hose for  
engine oil drain  
Hydraulic return filter  
Pilot circuit hydraulic filter

### TELEMATICS

CASE SiteWatch™ Telematics – includes  
hardware and a 3-yr Advanced  
data subscription

## OPTIONAL EQUIPMENT

### ENGINE

Refueling pump

### HYDRAULICS

Auxiliary hydraulics:

Single acting/joystick activated

Double acting/joystick activated – thumb

Multi-function with electronic pressure control/joystick activated with electronic proportional controls

Secondary low-flow/joystick activated

Proportional hydraulic controls

Hose Burst Check Valve – HBCV

### ATTACHMENTS

Long arm – 10 ft 0 in (3.05 m)

Quick coupler/Case multi-pin grabber

Tools:

Heavy-duty/Extreme-duty/Ditching

Buckets; Hammers; Thumbs;

Compaction plates.

Load holding control

### UPPER STRUCTURE

Rubber bumper guard – order through Service Parts

### UNDERCARRIAGE

27.6 in (700 mm) steel shoes, triple semi-grouser

Track guides – triple

### OPERATOR ENVIRONMENT

FOPS cab top guard – Level 2

Front grill guard – 2 x 2 in (50.8 x 50.8 mm) screen mesh

Front rock guard – vertical bars

Two piece/OPG 1

Front rock guard – vertical bars

One piece/OPG 2

Vandal guard (front window) with common key

Rain deflector – not available with Front guards

Sun visor

Side-view camera

LED Package:

Includes 1 Side view camera and 6 LED

Lights – 2 front cab mounted, 2 rear mounted and 1 mounted on each side

**CaseCE.com**

©2018 CNH Industrial America LLC. All rights reserved. CASE is a trademark registered in the United States and many other countries, owned by or licensed to CNH Industrial N.V., its subsidiaries or affiliates. CNH Industrial Capital is a trademark in the United States and many other countries, owned by or licensed to CNH Industrial N.V., its subsidiaries or affiliates. Printed in U.S.A. Contains 10% post-consumer fiber.

IMPORTANT: CASE Construction Equipment Inc. reserves the right to change these specifications without notice and without incurring any obligation relating to such change. Availability of some models and equipment builds vary according to the country in which the equipment is used. The illustrations and text may include optional equipment and accessories and may not include all standard equipment. Your CASE dealer/distributor will be able to give you details of the products and their specifications available in your area.



CASE Construction Equipment is biodiesel-friendly. NOTE: All engines meet current EPA emissions regulations. All specifications are stated in accordance with SAE Standards or Recommended Practices, where applicable.



Always read the Operator's Manual before operating any equipment. Inspect equipment before using it, and be sure it is operating properly. Follow the product safety signs and use any safety features provided.

Form No. CCE201806CX160DLC  
Replaces Form No. CCE201609CX160DLC

**CX160D LC**

**6 of 6**