



ENGINE

Model	Isuzu AQ-6HK1X
Emissions Certification	Tier 4 Final
Fuel	Requires ultra-low sulfur fuel B5 biodiesel tolerant
Type	Water-cooled, 4-cycle diesel, 6-cylinder in-line high pressure common rail system – electric control, VGT Turbocharger w/ air cooled intercooler, SCR system
Cylinders	6-cylinder in-line
Displacement	475 in ³ (7.8 L)
Bore/Stroke	4.53 x 4.92 in (115 x 125 mm)
Fuel injection	Direct injection – electronic
Fuel filter	Replaceable, full flow spin-on cartridge
Air filter	Dry type element w/ warning restriction indicator
Oil filter	Replaceable, full flow spin-on cartridge
Engine gradeability:	
Side-to-side	35°
Fore and aft	35°
Net horsepower – SAE J1349 @ 1900 RPM:	268 hp (200 kW)
Net max. torque – SAE J1349 @ 1500 RPM:	728 lbf-ft (988 N·m)
Cooling operating range:	122° to -4°F (50° to -20°C)
Oil	Requires low-ash oil CJ-4

DRIVETRAIN

Travel control	Dual stage relief/ counter balance design
Brakes	Mechanical disc
Service brakes	SAHR disc – each motor
Two speed travel:	
Max. high speed	3.4 mph (5.5 km/h)
Max. low speed	2.1 mph (3.3 km/h)
Automatic downshift	
Drawbar pull	61,373 lbf (273 kN)
Gradeability	70% – 35° Slope

ELECTRICAL

Voltage	24 Volts
Alternator rating	50 amp
Batteries	2 x 12 Volt
Battery reserve capacity	128 Ah/5 hour
Work lights – 4	24 Volt/70 watt
1 boom, 1 upper, 2 cab	

OPERATOR ENVIRONMENT

Air conditioner output	18,100 BTU/hr
Heater output	20,150 BTU/hr
Sound level inside cab – ISO6395	71 dBA
Electrical outlet	12 Volt
Cab interior light	10 watt
Rear view camera	Standard
Seat	Air-suspension, heated and 65° tiltable
Monitor:	
Rear view and side view – optional camera display; Mode 1: work mode; Travel mode; Attachment selection; Auto idle indicator; Fuel consumption gauge; Power boost icon; Fuel bar graph; Oil temperature bar graph; DEF/AdBlue bar graph; Auto glow indicator; Auxiliary mode display; Hour meter; Camera angle indicator; Mode 2: free swing/swing lock indicator; Light icon; Wiper icon; Mute icon; Seat belt icon; Warning messages; Time and date; Water temperature bar graph; DEF/AdBlue refill icon; Anti-theft icon; DTC indicator; Low output icon; SCR cleaning icon; SCR warning icons; Freeze protection; Trip meter; Pressure reading.	

Seat:

High-back seat w/ heat and air suspension; Adjustments: 65° tilt, manual weight, seat height headrest, lumbar support, backrest angle, pivoting armrests linked to consoles; Retractable seat belt and control consoles adjust independently of seat.

ATTACHMENT

Boom	21 ft 2 in (6.45 m)
HD Boom	21 ft 2 in (6.45 m)
Arm options:	
Standard	10 ft 8 in (3.25 m)
Short	8 ft 8 in (2.63 m)
Long	13 ft 3 in (4.04 m)
Bucket digging force*	51,638 lbf (230 kN)
w/ Auto Power-Boost	56,157 lbf (250 kN)

NOTE: *Digging force ratings based on ISO6015.

OPERATING WEIGHT

Operating weight	82,483 lb (37 414 kg)
w/ shoes	2 ft 7 in (800 mm)
w/ boom	21 ft 2 in (6.45 m)
w/ arm	10 ft 8 in (3.25 m)
w/ bucket	2,601 lb (1 180 kg)
w/ counterweight	16,314 lb (7 400 kg)

NOTE: W/ operator/full fuel/standard equipment.

GROUND PRESSURE

@ Standard operating weight 7.5 psi (0.52 bar)
w/ 31.5 in (800 mm) triple semi-grouser shoes

HYDRAULICS

System design	Open center
Main pumps	Two-variable displacement/ axial piston
Max. rated flow	79.3 gpm (300 L/min)
System pressures:	
Boom, arm and bucket	4,975 psi (343 bar)
w/ Power Boost	5,410 psi (373 bar)
Travel circuits	4,975 psi (343 bar)
Swing circuits	4,409 psi (304 bar)
Pilot pump	1 x gear design
Max. capacity	7.5 gpm (28.5 L/min)
Controls	w/ boom/arm holding valve
Right track travel, bucket, boom and arm acceleration.	1 x Four-spool section
Left track travel, auxiliary, swing, boom and arm acceleration.	1 x Five-spool section
Work mode selections	SP: Speed Priority H: Heavy-Duty A: Automatic
Swing motor	Fixed displacement axial piston
Swing final drive	Planetary gear reduction
Travel motor	Two-speed independent travel/axial piston

HYDRAULIC CYLINDERS

Boom cylinders	Two (2)
Cylinder bore	5.7 in (145 mm)
Cylinder rod diameter	3.9 in (100 mm)
Cylinder stroke	58.9 in (1 495 mm)
Arm cylinder	One (1)
Cylinder bore	6.7 in (170 mm)
Cylinder rod diameter	4.7 in (120 mm)
Cylinder stroke	68.8 in (1 748 mm)
Bucket cylinder	One (1)
Cylinder bore	5.9 in (150 mm)
Cylinder rod diameter	4.1 in (105 mm)
Cylinder stroke	47.6 in (1 210 mm)

SERVICE CAPACITIES

Fuel tank	153.2 gal (580 L)
Hydraulic system	92.5 gal (350 L)
Hydraulic tank	46.2 gal (175 L)
Engine oil w/ filter	12.7 gal (48 L)
Swing drive	1.3 gal (5 L)
Final drive	2.5 gal (9.5 L)
Cooling system	10.0 gal (38 L)
DEF Tank	40.2 gal (152 L)

OTHER SPECIFICATIONS

Swing speed	9.7 RPM
Swing torque	82,607 lbf-ft (112 kN-m)
Swing brake	Mechanical disc
Undercarriage:	
Length	16 ft 4 in (4 980 mm)
Track gauge	8 ft 6 in (2 600 mm)
Carrier rollers	2
Track rollers	8
Shoes – triple grouser	48
Shoe width – std.	2 ft 7 in (800 mm)
Link pitch	8.5 in (216 mm)
Track:	
Chain	Grease lubricated/strutted
Guides	Double
Adjustment	Hydraulic

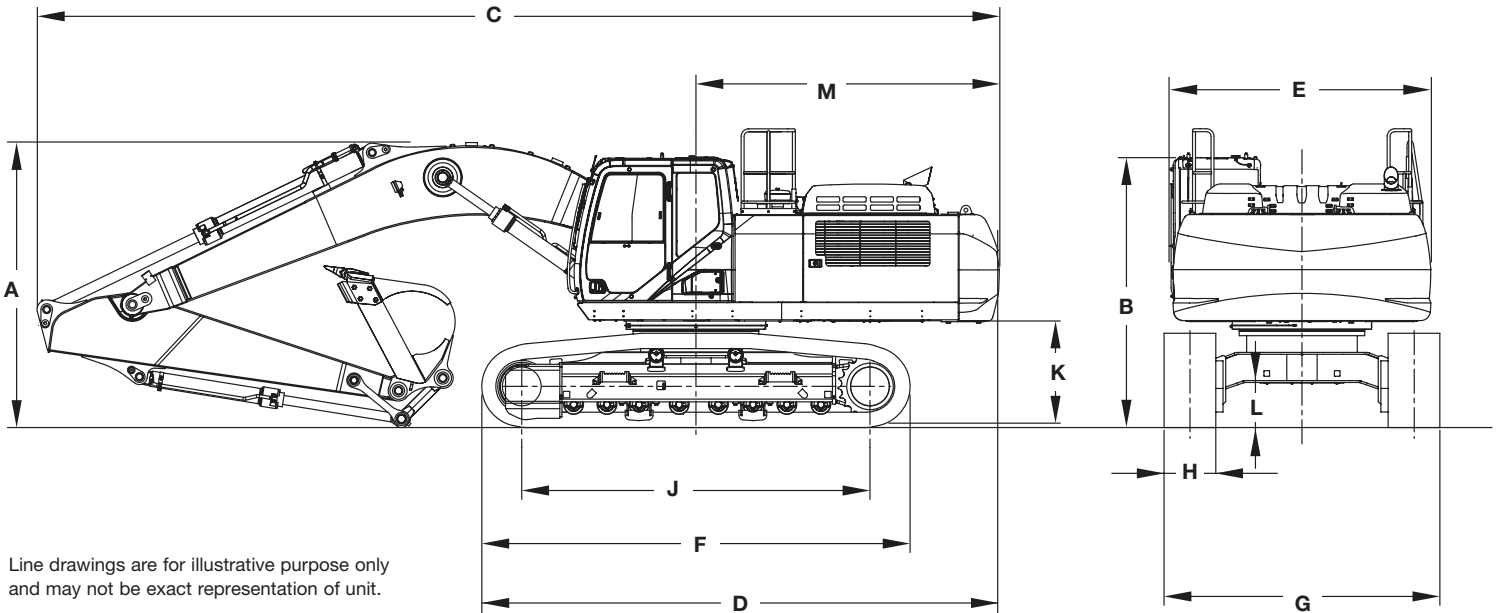

DIMENSIONS

	10 ft 8 in (3.25 m) Arm	8 ft 8 in (2.63 m) Arm	13 ft 3 in (4.04 m) Arm
A. Overall height – with attachment	11 ft 5 in (3 470 mm)	11 ft 11 in (3 630 mm)	11 ft 11 in (3 620 mm)
B. Cab height	10 ft 5 in (3 180 mm)	10 ft 5 in (3 180 mm)	10 ft 5 in (3 180 mm)
Overall height to top of guardrail	11 ft 5 in (3 470 mm)	11 ft 5 in (3 470 mm)	11 ft 5 in (3 470 mm)
C. Overall length – with attachment	36 ft 8 in (11 170 mm)	36 ft 10 in (11 220 mm)	36 ft 9 in (11 190 mm)
D. Overall length – without attachment	19 ft 9 in (6 010 mm)	19 ft 9 in (6 010 mm)	19 ft 9 in (6 010 mm)
E. Width of upper structure	9 ft 11 in (3 030 mm)	9 ft 11 in (3 030 mm)	9 ft 11 in (3 030 mm)
Width of upper structure with catwalks	11 ft 9 in (3 590 mm)	11 ft 9 in (3 590 mm)	11 ft 9 in (3 590 mm)
F. Track overall length	16 ft 4 in (4 980 mm)	16 ft 4 in (4 980 mm)	16 ft 4 in (4 980 mm)
G. Track overall width with 31.5 in (800 mm) shoes	11 ft 2 in (3 400 mm)	11 ft 2 in (3 400 mm)	11 ft 2 in (3 400 mm)
H. Track shoe width	2 ft 7 in (800 mm)	2 ft 7 in (800 mm)	2 ft 7 in (800 mm)
J. Center to center – idler to sprocket	13 ft 3 in (4 040 mm)	13 ft 3 in (4 040 mm)	13 ft 3 in (4 040 mm)
K. Upper structure ground clearance	4 ft 0 in (1 210 mm)	4 ft 0 in (1 210 mm)	4 ft 0 in (1 210 mm)
L. Minimum ground clearance	1 ft 7 in (470 mm)	1 ft 7 in (470 mm)	1 ft 7 in (470 mm)
M. Rear tail swing radius	11 ft 8 in (3 550 mm)	11 ft 8 in (3 550 mm)	11 ft 8 in (3 550 mm)
Operating weight*	82,483 lb (37 414 kg)	82,373 lb (37 364 kg)	83,144 lb (37 714 kg)
Ground pressure	7.5 psi (0.52 bar)	7.5 psi (0.52 bar)	7.7 psi (0.53 bar)

NOTE: *With 21 ft 2 in (6.45 m) boom, 31.5 in (800 mm) track shoe, 2,601 lb (1 180 kg) bucket, 165 lb (75 kg) operator, full fuel and standard equipment.

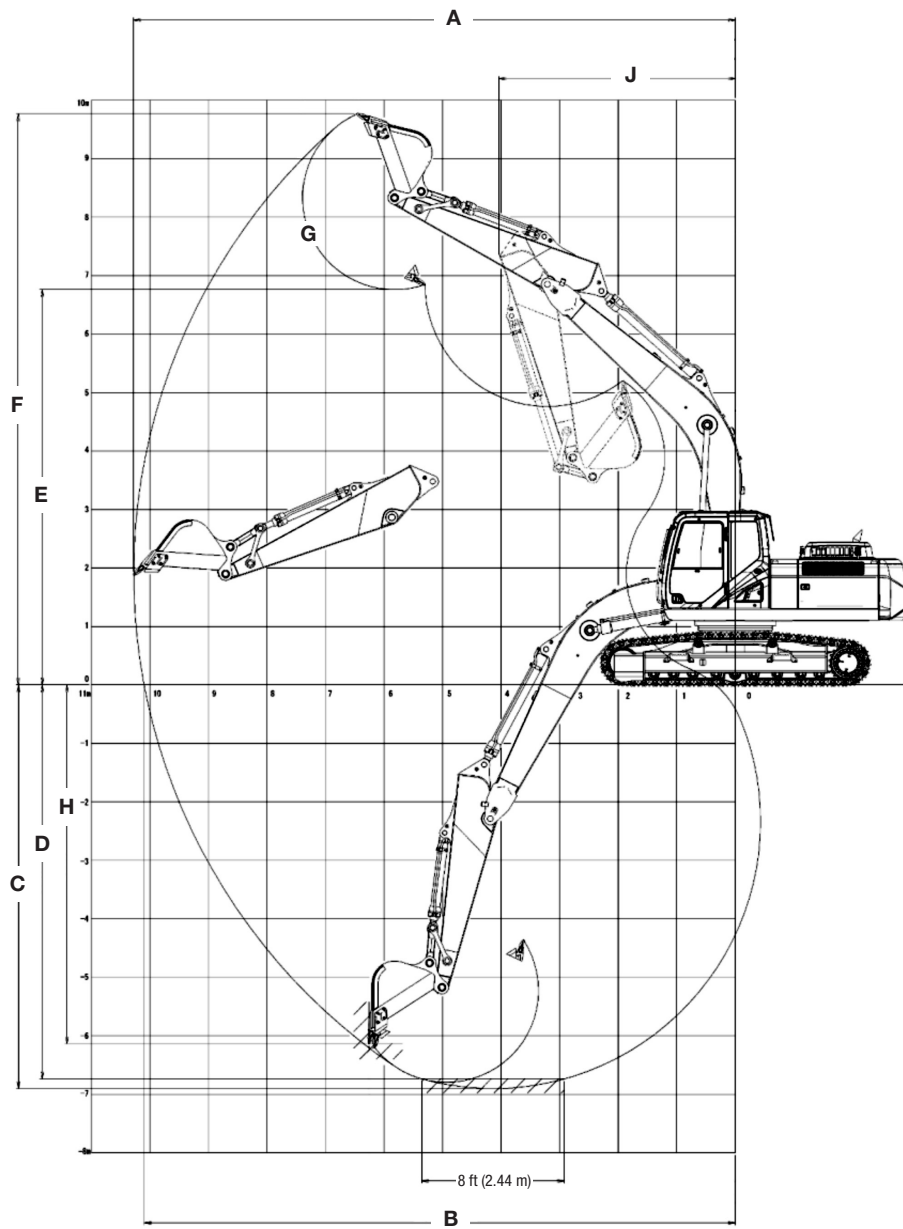

PERFORMANCE SPECS

	10 ft 8 in (3.25 m) Arm	8 ft 8 in (2.63 m) Arm	13 ft 3 in (4.04 m) Arm
A. Maximum dig radius	36 ft 8 in (11 170 mm)	34 ft 11 in (10 650 mm)	39 ft 1 in (11 900 mm)
B. Dig radius at groundline	36 ft 0 in (10 980 mm)	34 ft 3 in (10 450 mm)	38 ft 5 in (11 710 mm)
C. Maximum dig depth	24 ft 1 in (7 340 mm)	22 ft 1 in (6 720 mm)	26 ft 8 in (8 140 mm)
D. Dig depth – 8 ft 0 in (2.44 m) level bottom	23 ft 7 in (7 190 mm)	21 ft 5 in (6 540 mm)	26 ft 3 in (8 010 mm)
E. Dump height	23 ft 9 in (7 240 mm)	23 ft 4 in (7 110 mm)	24 ft 8 in (7 530 mm)
F. Maximum reach height	34 ft 1 in (10 380 mm)	33 ft 9 in (10 280 mm)	34 ft 11 in (10 650 mm)
G. Bucket rotation	173°	173°	173°
H. Maximum vertical wall dig depth	20 ft 10 in (6 340 mm)	19 ft 7 in (5 980 mm)	23 ft 0 in (7 010 mm)
J. Minimum swing radius	14 ft 10 in (4 510 mm)	14 ft 7 in (4 440 mm)	14 ft 10 in (4 530 mm)
Arm digging force:			
Standard	36,981 lbf (165 kN)	43,770 lbf (195 kN)	31,473 lbf (140 kN)
Power Boost	40,196 lbf (179 kN)	47,592 lbf (212 kN)	34,216 lbf (152 kN)
Bucket digging force:			
Standard	51,639 lbf (230 kN)	51,639 lbf (230 kN)	51,639 lbf (230 kN)
Power Boost	56,157 lbf (250 kN)	56,157 lbf (250 kN)	56,157 lbf (250 kN)

NOTE: *Machine equipped with 21 ft 2 in (6.45 m) boom.

LIFT CAPACITIES

10 ft 8 in (3.25 m) Arm Lift capacities calculated using a 2,579 lb (1 170 kg) bucket, 16,314 lb (7 400 kg) counterweight.

Load (Lift Point) Height	5 ft (1.5 m)		10 ft (3 m)		15 ft (4.5 m)		20 ft (6 m)		25 ft (7.5 m)		30 ft (9 m)		35 ft (10.5 m)		MAXIMUM REACH		
	END	SIDE	END	SIDE	END	SIDE	END	SIDE	END	SIDE	END	SIDE	END	SIDE	@	END	SIDE
+30 ft (9 m)															26 ft 7 in (8.23 m)	8,850 lb* (3 980 kg)*	8,850 lb* (3 980 kg)*
+25 ft (7.5 m)									14,350 lb* (6 750 kg)*	14,350 lb* (6 750 kg)*	9,950 lb* (5 330 kg)*	9,950 lb* (5 330 kg)*			30 ft 6 in (9.37 m)	8,250 lb* (3 740 kg)*	8,250 lb* (3 740 kg)*
+20 ft (6 m)									16,150 lb* (7 380 kg)*	16,150 lb* (7 380 kg)*	14,650 lb* (6 690 kg)*	12,000 lb (5 600 kg)			33 ft 0 in (10.11 m)	8,050 lb* (3 660 kg)*	8,050 lb* (3 660 kg)*
+15 ft (4.5 m)					(7 700 kg)*	(7 700 kg)*	20,900 lb* (9 660 kg)*	20,900 lb* (9 660 kg)*	17,700 lb* (8 180 kg)*	16,000 lb (7 440 kg)	15,700 lb* (7 270 kg)*	11,650 lb (5 430 kg)	(4 040 kg)*	(4 040 kg)	34 ft 7 in (10.55 m)	8,150 lb* (3 700 kg)*	8,150 lb* (3 700 kg)*
+10 ft (3 m)			45,450 lb* (17 480 kg)*	45,450 lb* (17 480 kg)*	33,950 lb* (15 750 kg)*	33,300 lb* (15 450 kg)	24,700 lb* (11 440 kg)	21,800 lb (10 110 kg)	20,000 lb* (9 230 kg)*	15,250 lb (7 080 kg)	17,050 lb* (7 850 kg)*	11,250 lb (5 230 kg)	9,550 lb* (5 450 kg)*	8,450 lb (3 960 kg)	35 ft 3 in (10.73 m)	8,450 lb* (3 830 kg)*	8,350 lb (3 780 kg)
+5 ft (1.5 m)			17,200 lb* (7 290 kg)*	17,200 lb* (7 290 kg)*	39,150 lb* (17 950 kg)*	31,550 lb (14 650 kg)	27,900 lb* (12 900 kg)*	20,450 lb (9 500 kg)	21,850 lb* (10 080 kg)*	14,500 lb (6 750 kg)	16,850 lb (7 830 kg)	10,800 lb (5 030 kg)	9,500 lb* (5 600 kg)*	8,300 lb (3 860 kg)	35 ft 1 in (10.69 m)	8,950 lb* (4 070 kg)*	8,250 lb (3 730 kg)
Groundline			23,350 lb* (10 360 kg)*	23,350 lb* (10 360 kg)*	40,950 lb* (18 830 kg)*	30,000 lb (13 940 kg)	29,600 lb* (13 680 kg)*	19,500 lb (9 060 kg)	21,950 lb (10 200 kg)	13,950 lb (6 480 kg)	16,450 lb (7 660 kg)	10,500 lb (4 880 kg)			34 ft 2 in (10.43 m)	9,850 lb* (4 460 kg)*	8,500 lb (3 850 kg)
-5 ft (-1.5 m)	23,250 lb* (10 400 kg)*	23,250 lb* (10 400 kg)*	31,800 lb* (14 140 kg)*	31,800 lb* (14 140 kg)*	40,800 lb* (18 840 kg)*	29,700 lb* (13 810 kg)	29,700 lb* (13 720 kg)*	19,050 lb (8 850 kg)	21,600 lb (10 040 kg)	13,650 lb (6 340 kg)	16,350 lb (7 590 kg)	10,350 lb (4 810 kg)			32 ft 6 in (9.92 m)	11,300 lb* (5 090 kg)*	9,200 lb (4 150 kg)
-10 ft (-3 m)	32,100 lb* (14 390 kg)*	32,100 lb* (14 390 kg)*	43,100 lb* (19 080 kg)*	43,100 lb* (19 080 kg)*	38,800 lb* (17 930 kg)*	30,000 lb (13 950 kg)	28,700 lb* (13 280 kg)*	19,200 lb (8 910 kg)	21,600 lb (10 030 kg)	13,750 lb (6 390 kg)	(7 620 kg)	(4 900 kg)			29 ft 10 in (9.13 m)	13,700 lb* (6 160 kg)*	10,550 lb (4 750 kg)
-15 ft (-4.5 m)	43,000 lb* (19 170 kg)*	43,000 lb* (19 170 kg)*	47,750 lb* (22 150 kg)*	47,750 lb* (22 150 kg)*	34,100 lb* (15 830 kg)*	30,500 lb (14 180 kg)	25,400 lb* (11 840 kg)*	19,700 lb (9 140 kg)	18,450 lb* (8 750 kg)*	14,350 lb (6 650 kg)					26 ft 1 in (8.01 m)	16,150 lb* (7 300 kg)*	13,200 lb (5 900 kg)
-20 ft (-6 m)			33,900 lb* (16 040 kg)*	33,900 lb* (16 040 kg)*	24,850 lb* (11 800 kg)*	24,850 lb* (11 800 kg)*	16,900 lb* (8 300 kg)*	16,900 lb* (8 300 kg)*							20 ft 7 in (6.40 m)	15,350 lb* (7 040 kg)*	15,350 lb* (7 040 kg)*

8 ft 8 in (2.63 m) Arm Lift capacities calculated using a 2,734 lb (1 240 kg) bucket, 16,314 lb (7 400 kg) counterweight.

Load (Lift Point) Height	5 ft (1.5 m)		10 ft (3 m)		15 ft (4.5 m)		20 ft (6 m)		25 ft (7.5 m)		30 ft (9 m)		MAXIMUM REACH				
	END	SIDE	END	SIDE	END	SIDE	END	SIDE	END	SIDE	END	SIDE	@	END	SIDE		
+30 ft (9 m)														24 ft 1 in (7.5 m)	12,500 lb* (5 620 kg)*	12,500 lb* (5 620 kg)*	
+25 ft (7.5 m)									16,250 lb* (7 400 kg)*	16,250 lb* (7 400 kg)*					28 ft 5 in (8.75 m)	11,550 lb* (5 230 kg)*	11,550 lb* (5 230 kg)*
+20 ft (6 m)									17,450 lb* (7 970 kg)*	16,150 lb (7 500 kg)*	15,650 lb* (7 140 kg)*	11,500 lb (5 390 kg)			31 ft 2 in (9.55 m)	11,250 lb* (5 080 kg)*	10,600 lb (4 770 kg)
+15 ft (4.5 m)					27,700 lb* (12 770 kg)*	27,700 lb* (12 770 kg)*	22,350 lb* (10 350 kg)*	22,000 lb (10 210 kg)*	18,700 lb* (8 650 kg)*	15,500 lb (7 210 kg)	16,550 lb* (7 640 kg)*	11,250 lb (5 250 kg)			32 ft 10 in (10.02 m)	11,250 lb* (5 110 kg)*	9,450 lb (4 250 kg)
+10 ft (3 m)					33,400 lb* (15 460 kg)*	32,900 lb (15 520 kg)	25,900 lb* (12 010 kg)*	21,100 lb (9 780 kg)	20,700 lb* (9 550 kg)*	14,800 lb (6 870 kg)	16,900 lb (7 870 kg)	10,850 lb (5 070 kg)			33 ft 6 in (10.21 m)	11,550 lb* (5 260 kg)*	8,850 lb (4 020 kg)
+5 ft (1.5 m)					38,600 lb* (17 850 kg)*	30,450 lb (14 130 kg)	28,550 lb* (13 210 kg)*	19,850 lb (9 220 kg)	22,000 lb* (10 220 kg)	14,100 lb (6 560 kg)	16,500 lb (7 680 kg)	10,500 lb (4 890 kg)			33 ft 5 in (10.17 m)	12,200 lb* (5 550 kg)*	8,750 lb (3 970 kg)
Groundline					40,600 lb* (18 720 kg)*	29,350 lb (13 650 kg)	29,550 lb* (13 660 kg)*	19,050 lb (8 850 kg)	21,600 lb (10 050 kg)	13,600 lb (6 330 kg)	16,250 lb (7 550 kg)	10,250 lb (4 770 kg)			32 ft 5 in (9.89 m)	13,350 lb* (6 050 kg)*	9,100 lb (4 120 kg)
-5 ft (-1.5 m)	21,500 lb* (9 280 kg)*	21,500 lb* (9 280 kg)*	32,150 lb* (14 270 kg)*	32,150 lb* (14 270 kg)*	39,850 lb* (18 380 kg)*	29,550 lb (13 740 kg)	29,300 lb* (13 520 kg)*	18,850 lb (8 750 kg)	21,400 lb (9 960 kg)	13,450 lb (6 250 kg)	16,300 lb (7 560 kg)	10,300 lb (4 780 kg)			30 ft 8 in (9.35 m)	15,200 lb* (6 880 kg)*	9,950 lb (4 510 kg)
-10 ft (-3 m)	35,450 lb* (15 900 kg)*	35,450 lb* (15 900 kg)*	46,900 lb* (20 730 kg)*	46,900 lb* (20 730 kg)*	36,800 lb* (17 000 kg)*	30,000 lb (13 950 kg)	27,500 lb* (12 750 kg)*	19,100 lb (8 880 kg)	20,850 lb* (9 720 kg)*	13,800 lb (6 390 kg)					27 ft 10 in (8.51 m)	16,450 lb* (7 470 kg)*	11,700 lb (5 270 kg)
-15 ft (-4.5 m)			41,400 lb* (19 220 kg)*	41,400 lb* (19 220 kg)*	30,700 lb* (14 290 kg)*	30,050 lb (13 980 kg)	22,750 lb* (10 680 kg)*	19,650 lb (9 120 kg)							23 ft 9 in (7.3 m)	15,850 lb* (7 150 kg)*	15,250 lb (6 800 kg)

NOTE: *Lift capacities do not exceed 75% of the minimum tipping load or 87% of the hydraulic lift capacity. Capacities that are marked with an asterisk are hydraulic limited.

LIFT CAPACITIES

13 ft 0 in (4.04 m) Arm Lift capacities calculated using a 2,315 lb (1 050 kg) bucket, 16,314 lb (7 400 kg) counterweight.

Load (Lift Point) Height	5 ft (1.5 m)		10 ft (3 m)		15 ft (4.5 m)		20 ft (6 m)		25 ft (7.5 m)		30 ft (9 m)		35 ft (10.5 m)		MAXIMUM REACH			
	END	SIDE	END	SIDE	END	SIDE	END	SIDE	END	SIDE	END	SIDE	END	SIDE	@	END	SIDE	
+30 ft (9 m)												(3 620 kg)*	(3 620 kg)*			29 ft 9 in (9.19 m)	6,650 lb* (2 990 kg)*	6,650 lb* (2 990 kg)*
+25 ft (7.5 m)																33 ft 3 in (10.20 m)	6,250 lb* (2 820 kg)*	6,250 lb* (2 820 kg)*
+20 ft (6 m)																35 ft 7 in (10.88 m)	6,100 lb* (2 760 kg)*	6,100 lb* (2 760 kg)*
+15 ft (4.5 m)																		
+10 ft (3 m)																		
+5 ft (1.5 m)																		
Groundline																		
-5 ft (-1.5 m)																		
-10 ft (-3 m)																		
-15 ft (-4.5 m)																		
-20 ft (-6 m)																		

NOTE: *Lift capacities do not exceed 75% of the minimum tipping load or 87% of the hydraulic lift capacity. Capacities that are marked with an asterisk are hydraulic limited.

STANDARD EQUIPMENT

ENGINE

Isuzu AQ-6HK1X
Tier 4 Final Certified
Selective Catalytic Reduction – SCR
Diesel Oxidation Catalyst – DOC
Cooled Exhaust Gas Recirculation – CEGR
EGR Coolers
Six-cylinder turbo-charged diesel
VGT turbocharger
Electronic fuel injection
High pressure common rail system
Neutral safety start
Auto-engine warm up
Glow-plug pre-heat
Fuel Economy Assist System – FEA
Engine Protection Feature – EPF
Dual-stage fuel filtration
Dual element air filter
Remote oil filter
Drain for fuel tank
Remote engine oil drain
500-hour engine oil change interval
24 Volt system
Engine oil sample port
Battery disconnect switch
Air pre-cleaner – Cyclone
High ambient temperature cooling package
Emergency engine stop
External Fuel and DEF gauges
Fan housing
Fuel cooler
Fuel filter restriction indicator
Fuel shut-off valve
Idle start
Radiator, oil cooler,
intercooler – protective screen

FUEL ECONOMY SYSTEMS

Engine Idle/Fuel Economy System:
Auto-idle
One-touch idle
Auto-idle shut-down
BEC – Boom Economy Control
AEC – Auto Economy Control
SWC – Swing Relief Control
SSC – Spool Stroke Control

HYDRAULICS

Auto power boost
Auto swing priority
Arm speed assistance – 2 pump flow
Auxiliary flow control
Auxiliary valve
Boom speed assistance – 2 pump flow
Bucket curl assist
Control levers pre-wired for
auxiliary hydraulics
Electronically controlled hydraulic pumps
Holding valve – Boom and Arm
Fire wall
Hydraulic filter restriction indicator
Neutral pump de-stroke
Oil cooler

Power save
Pump stand-by pressure
Auto travel speed change
Selectable work modes
Free swing
Hydraulic oil sample port
Control pattern selector
Pre-set auxiliary pump settings
Auxiliary valve
5,000-hour hydraulic oil change interval
1,000-hour hydraulic filter change interval
SAHR brake

UPPER STRUCTURE

ISO mirrors – 3
Cab ISO-Mounts – fluid and spring
Upper mounted work light – 70 watt
Swivel guard belly pan
Center cover – over main CV
Fuel tank belly pan
Handrail – RH access
ISO guard rails
Lifting eyes for counterweight
Lockable fuel cap, service doors and toolbox

ATTACHMENTS

Boom – 21 ft 2 in (6.45 m)
Arm – 10 ft 8 in (3.25 m)
Heavy-duty bucket linkage
Boom mounted work light – 70 watt
Auxiliary pipe brackets
Centralized grease fittings
Attachment cushion valve
Arm and boom regeneration
Bucket anti-clatter device
Chrome pins
Easy Maintenance System (EMS) bushings
Teardrop pin retention keepers

OPERATOR ENVIRONMENT

ROPS protection
FOPS cab top guard – Level 1
Pressurized cab
Face vent
Cab lights – 2
Interior dome light
One-touch lock front window
One piece window – right
Safety glass windows
Gate lock hydraulic activation
Emergency exit and hammer
Clear polycarbonate roof window
with sunshade
AC/heat/defrost with auto climate control
LED Color monitor – 7 in (180 mm)
26 selectable languages for monitor
On-board diagnostic system
10 programmable attachments settings on
monitor – 5 single flow, 5 dual flow
Seat belt – 3 in (76 mm)
Heated high-back cloth seat with air
suspension and 65° tilt adjustment
Sliding seat – 3.54 in (90 mm)

Adjustable armrests
Tilting consoles – 4-position
Sliding cockpit – 3.15 in (80 mm)
Low-effort joystick controls
Controls pre-wired for auxiliary
Single pedal travel
Straight travel
AM/FM radio with antenna, 2 speakers and
Bluetooth capabilities
Aux-in port for personal electronics
Radio mute switch – joystick
Rear-view camera
Anti-theft system – start code system
Rubber floor mat
12 Volt electric outlet
24 Volt cigarette lighter
Windshield wiper/washer
Cup holder
Storage compartments
Warm/cool storage compartment
Travel alarm with cancel switch
Ignition keys
One key start & lock-up
Cab filter – external
Cab handrails
Operator's manual

UNDERCARRIAGE

Long undercarriage
31.5 in (800 mm) steel shoes,
triple semi-grouser
Full overlap turntable bearing tub
Double track chain guides
Hydraulic track adjustment
Sealed link chain
Steps
Carbody belly pan – swivel guard
X-pattern carbody
Lashing points – tie downs
Extra Filter Kit:
Engine oil filter
Filter wrench
Fuel filters
Grease gun
Green plug oil drain hose for
engine oil drain
Hydraulic return filter
Pilot circuit hydraulic filter

TELEMATICS

CASE SiteWatch™ Telematics – includes
hardware and a 3-yr Advanced
data subscription

OPTIONAL EQUIPMENT

ENGINE

Refueling pump

HYDRAULICS

Auxiliary hydraulics:

Single acting/joystick activated

Double acting/joystick activated – thumb

Multi-function/joystick activated

Multi-function with electronic pressure

control/joystick activated with

electronic proportional controls

Secondary low-flow/joystick activated

Proportional hydraulic controls

Hose Burst Check Valve – HBCV

ATTACHMENTS

Heavy-duty boom – 21 ft 2 in (6.45 m)

Short arm – 8 ft 8 in (2.63 m)

Heavy-duty arm – 10 ft 8 in (3.25 m)

Long arm – 13 ft 3 in (4.04 m)

Quick coupler/Case multi-pin grabber

Tools:

Heavy-duty/Extreme-duty/Ditching

Buckets; Hammers; Thumbs;

Compaction plates.

Load holding control

UPPER STRUCTURE

Rubber bumper guard – order through
Service Parts

Catwalk – left and right side

UNDERCARRIAGE

27.6 in (700 mm) steel shoes,
triple semi-grouser

33.5 in (850 mm) steel shoes,
triple semi-grouser

OPERATOR ENVIRONMENT

FOPS cab top guard – Level 2

Front grill guard – 2 x 2 in (50.8 x 50.8 mm)
screen mesh

Front rock guard – vertical bars

Two piece/OPG 1

Front rock guard – vertical bars

One piece/OPG 2

Vandal guard (front window) with
common key

Rain deflector – not available with
Front guards

Sun visor

Side-view camera

LED Package:

Includes 1 Side view camera and 6 LED

Lights – 2 front cab mounted, 2 rear

mounted and 1 mounted on each side

CaseCE.com

©2020 CNH Industrial America LLC. All rights reserved. CASE is a trademark registered in the United States and many other countries, owned by or licensed to CNH Industrial N.V., its subsidiaries or affiliates. CNH Industrial Capital is a trademark in the United States and many other countries, owned by or licensed to CNH Industrial N.V., its subsidiaries or affiliates. Printed in U.S.A. Contains 10% post-consumer fiber.

IMPORTANT: CASE Construction Equipment Inc. reserves the right to change these specifications without notice and without incurring any obligation relating to such change. Availability of some models and equipment builds vary according to the country in which the equipment is used. The illustrations and text may include optional equipment and accessories and may not include all standard equipment. Your CASE dealer/distributor will be able to give you details of the products and their specifications available in your area.



CASE Construction Equipment is biodiesel-friendly. NOTE: All engines meet current EPA emissions regulations. All specifications are stated in accordance with SAE Standards or Recommended Practices, where applicable.



Always read the Operator's Manual before operating any equipment. Inspect equipment before using it, and be sure it is operating properly. Follow the product safety signs and use any safety features provided.

Form No. CCE202008CX350D

Replaces Form No. CCE201601CX350D

CX350D

7 of 7