

ENGINE

Model	Isuzu AQ-6HK1X
Emissions Certification	Tier 4 Final
Fuel	Requires ultra-low sulfur fuel B5 biodiesel tolerant
Type	Water-cooled, 4-cycle diesel, 6-cylinder in-line high pressure common rail system – electric control, VGT Turbocharger w/ air cooled intercooler, SCR system
Cylinders	6-cylinder in-line
Displacement	475 in ³ (7.8 L)
Bore/Stroke	4.53 x 4.92 in (115 x 125 mm)
Fuel injection	Direct injection – electronic
Fuel filter	Replaceable, full flow spin-on cartridge
Air filter	Dry type element w/ warning restriction indicator
Oil filter	Replaceable, full flow spin-on cartridge
Engine gradeability:	
Side-to-side	35°
Fore and aft	35°
Net horsepower – SAE J1349 @ 1900 RPM:	268 hp (200 kW)
Net max. torque – SAE J1349 @ 1500 RPM:	729 lbf-ft (988 N-m)
Cooling operating range:	122° to -4°F (50° to -20°C)
Oil	Requires low-ash oil CJ-4

DRIVETRAIN

Travel control	Dual stage relief/ counter balance design
Brakes	Mechanical disc
Service brakes	SAHR disc – each motor
Two speed travel:	
Max. high speed	3.5 mph (5.6 km/h)
Max. low speed	2.1 mph (3.3 km/h)
Automatic downshift	
Drawbar pull	60,900 lbf (271 kN)
Gradeability	70% – 35° Slope

ELECTRICAL

Voltage	24 Volts
Alternator rating	50 amp
Batteries	2 x 12 Volt
Battery reserve capacity	128 Ah/5 hour
Work lights – 4 1 boom, 1 upper, 2 cab	24 Volt/70 watt

OPERATOR ENVIRONMENT

Air conditioner output	18,100 BTU/hr
Heater output	20,150 BTU/hr
Sound level inside cab – ISO6395	70 dBA
Electrical outlet	12 Volt
Cab interior light	10 watt
Rear view camera	Standard
Seat	Air-suspension, heated and 65° tilttable
Monitor:	
	Rear view and side view – optional camera display; Mode 1: work mode; Travel mode; Attachment selection; Auto idle indicator; Fuel consumption gauge; Power boost icon; Fuel bar graph; Oil temperature bar graph; DEF/AdBlue bar graph; Auto glow indicator; Auxiliary mode display; Hour meter; Camera angle indicator; Mode 2: free swing/swing lock indicator; Light icon; Wiper icon; Mute icon; Seat belt icon; Warning messages; Time and date; Water temperature bar graph; DEF/AdBlue refill icon; Anti-theft icon; DTC indicator; Low output icon; SCR cleaning icon; SCR warning icons; Freeze protection; Trip meter; Pressure reading.

Seat:
High-back seat w/ heat and air suspension;
Adjustments: 65° tilt, manual weight, seat
height headrest, lumbar support, backrest
angle, pivoting armrests linked to consoles;
Retractable seat belt and control consoles
adjust independently of seat.

ATTACHMENT

Boom	35 ft 4 in (10.78 m)
Arm options:	
Standard	25 ft 0 in (7.63 m)
Bucket digging force*	24,500 lbf (109 kN)

NOTE: *Digging force ratings based on ISO6015.

OPERATING WEIGHT

Operating weight	88,200 lb (40 000 kg)
w/ shoes	31.5 in (800 mm)
w/ boom	35 ft 4 in (10.78 m)
w/ arm	25 ft 0 in (7.63 m)
w/ bucket	1,323 lb (600 kg)
w/ counterweight	19,400 lb (8 800 kg)

NOTE: W/ operator/full fuel/standard equipment.

GROUND PRESSURE

@ Standard operating weight 8.1 psi (0.56 bar)
w/ 31.5 in (800 mm) triple semi-grouser shoes

HYDRAULICS

System design	Open center
Main pumps	Two-variable displacement/ axial piston
Max. rated flow per pump:	79.3 gpm (300 L/min)
Max. rated flow total:	158.5 gpm (600 L/min)
System pressures:	
Boom, arm	4,970 psi (343 bar)
w/ Power Boost	5,410 psi (373 bar)
Bucket	3,840 psi (265 bar)
Travel circuits	4,970 psi (343 bar)
Swing circuits	4,050 psi (279 bar)
Pilot pump	1 x gear design
Max. capacity	7.5 gpm (28.5 L/min)
Controls	w/ boom/arm holding valve
Right track travel, bucket, boom and arm acceleration.	1 x Four-spool section
Left track travel, auxiliary, swing, boom and arm acceleration.	1 x Five-spool section
Work mode selections	SP: Speed Priority H: Heavy-Duty A: Automatic
Swing motor	Fixed displacement axial piston
Swing final drive	Planetary gear reduction
Travel motor	Two-speed independent travel/axial piston

HYDRAULIC CYLINDERS

Boom cylinders	Two (2)
Cylinder bore	5.7 in (145 mm)
Cylinder rod diameter	3.9 in (100 mm)
Cylinder stroke	58.9 in (1 495 mm)
Arm cylinder	One (1)
Cylinder bore	5.9 in (150 mm)
Cylinder rod diameter	4.1 in (105 mm)
Cylinder stroke	68.3 in (1 737 mm)
Bucket cylinder	One (1)
Cylinder bore	4.7 in (120 mm)
Cylinder rod diameter	3.3 in (85 mm)
Cylinder stroke	39.8 in (1 010 mm)

SERVICE CAPACITIES

Fuel tank	153.2 gal (580 L)
Hydraulic system	92.5 gal (350 L)
Hydraulic tank	46.2 gal (175 L)
Engine oil w/ filter	12.7 gal (48 L)
Swing drive	1.3 gal (5 L)
Final drive	2.5 gal (9.5 L)
Cooling system	10.0 gal (38 L)
DEF Tank	40.2 gal (152 L)

OTHER SPECIFICATIONS

Swing speed	9.7 RPM
Swing torque	76,000 lbf-ft (103 000 N-m)
Swing brake	Mechanical disc
Undercarriage:	
Length	16 ft 4 in (4 980 mm)
Track gauge	8 ft 6 in (2 600 mm)
Carrier rollers – each side	2
Track rollers – each side	8
Shoes – triple grouser – each side	48
Shoe width – std.	31.5 in (800 mm)
Link pitch	8.5 in (216 mm)
Track:	
Chain	Grease lubricated/strutted
Guides	Double
Adjustment	Hydraulic

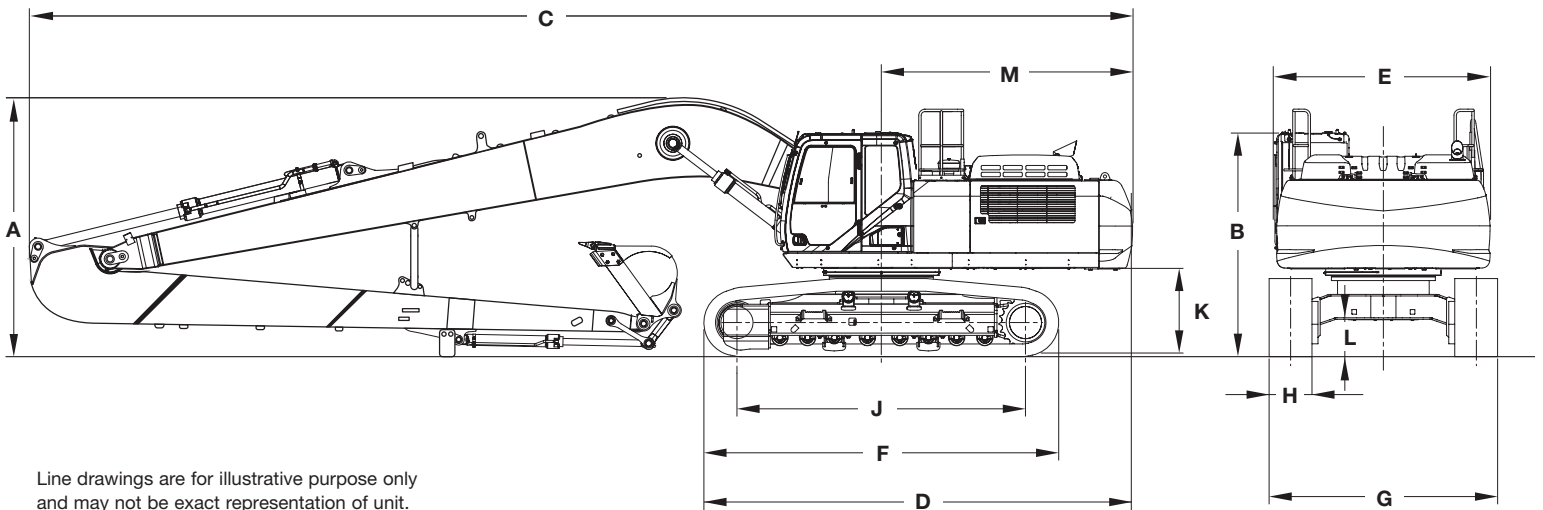

Line drawings are for illustrative purpose only and may not be exact representation of unit.

DIMENSIONS

	25 ft 0 in (7.63 m) Arm
A. Overall height – top of boom	11 ft 11 in (3 630 mm)
B. Cab height	10 ft 5 in (3 180 mm)
Overall height to top of guardrail	11 ft 5 in (3 470 mm)
C. Overall length – with attachment	50 ft 9 in (15 480 mm)
D. Overall length – without attachment	19 ft 9 in (6 010 mm)
E. Width of upper structure	10 ft 0 in (3 060 mm)
Width of upper structure with catwalks	11 ft 9 in (3 590 mm)
F. Track overall length	16 ft 4 in (4 980 mm)
G. Track overall width with 31.5 in (800 mm) shoes	11 ft 2 in (3 400 mm)
H. Track shoe width	31.5 in (800 mm)
J. Center to center – idler to sprocket	13 ft 3 in (4 040 mm)
K. Upper structure ground clearance	4 ft 0 in (1 210 mm)
L. Minimum ground clearance	1 ft 7 in (470 mm)
M. Rear tail swing radius	11 ft 8 in (3 550 mm)

NOTE: *With 35 ft 4 in (10.78 m) boom, 31.5 in (800 mm) track shoe, 1,323 lb (600 kg) bucket, 165 lb (75 kg) operator, full fuel and standard equipment.

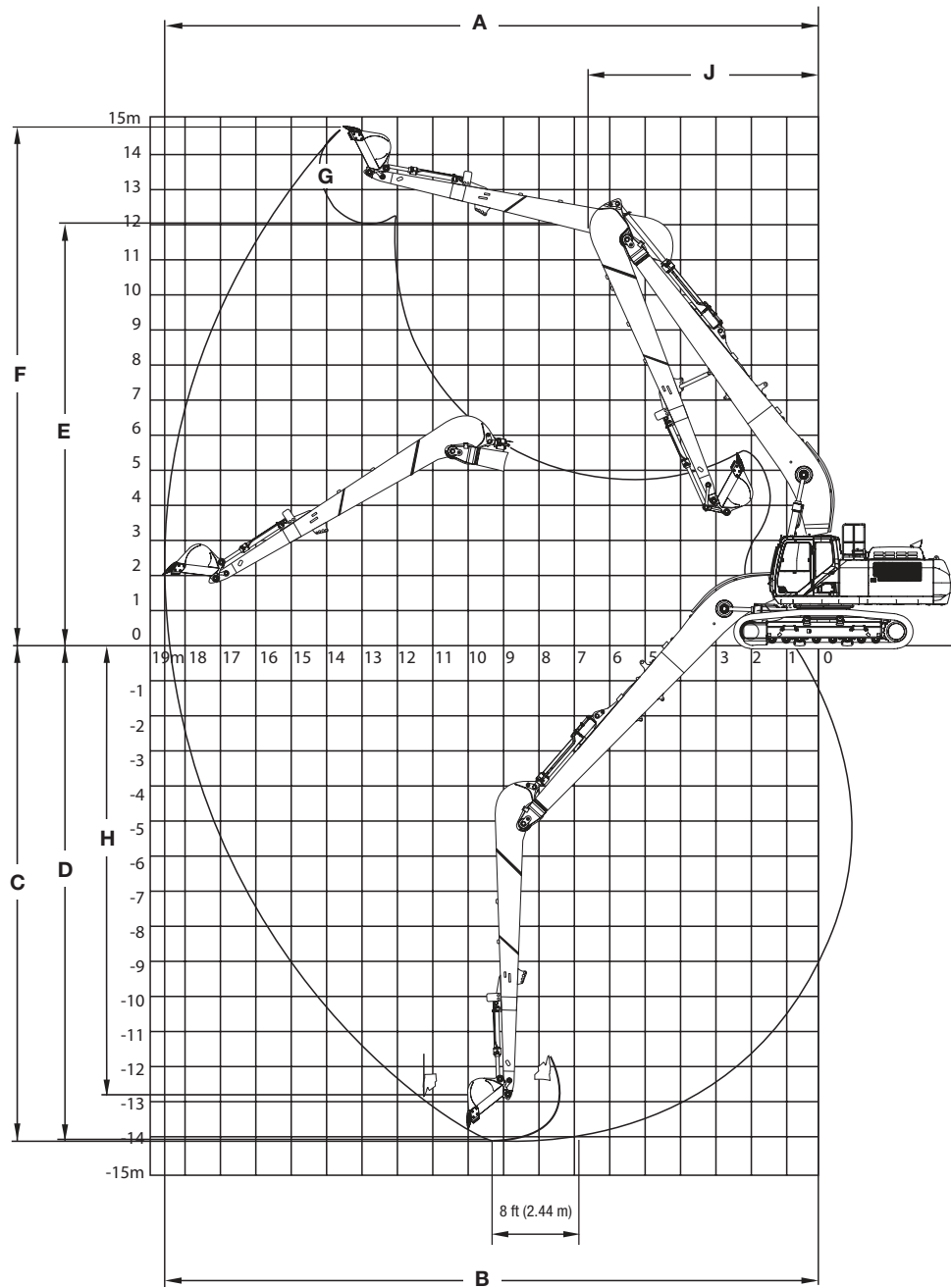

PERFORMANCE SPECS

	25 ft 0 in (7.63 m) Arm
A. Maximum dig radius	61 ft 3 in (18 660 mm)
B. Dig radius at groundline	60 ft 10 in (18 540 mm)
C. Maximum dig depth	46 ft 3 in (14 090 mm)
D. Dig depth – 8 ft 0 in (2.44 m) level bottom	45 ft 11 in (13 990 mm)
E. Dump height	39 ft 8 in (12 080 mm)
F. Maximum reach height	48 ft 5 in (14 770 mm)
G. Bucket rotation	177°
H. Maximum vertical wall dig depth	41 ft 8 in (12 690 mm)
J. Minimum swing radius	21 ft 3 in (6 470 mm)
Arm digging force:	
Standard	14,900 lbf (66.2 kN)
Power Boost	16,200 lbf (72.0 kN)
Bucket digging force:	
Standard	24,500 lbf (109.0 kN)

NOTE: *Machine equipped with 35 ft 4 in (10.78 m) boom.

LIFT CAPACITIES

25 ft 0 in (7.63 m) Arm Lift capacities calculated using a 1,320 lb (600 kg) bucket, 19,430 lb (8 810 kg) counterweight.

Load (Lift Point) Height	MINIMUM REACH		5 ft (1.5 m)		10 ft (3 m)		15 ft (4.5 m)		20 ft (6 m)		25 ft (7.5 m)		30 ft (9 m)		
	@	END SIDE	END SIDE	END SIDE	END SIDE	END SIDE	END SIDE	END SIDE	END SIDE	END SIDE	END SIDE	END SIDE	END SIDE		
+45 ft (13.5 m)	43 ft 8 in (13.3 m)	(700 kg)*	(700 kg)*												
+40 ft (12 m)	43 ft 11 in (13.4 m)	2,850 lb* (1 380 kg)*	2,850 lb* (1 380 kg)*												
+35 ft (10.5 m)	43 ft 6 in (13.2 m)	4,150 lb* (1 940 kg)*	4,150 lb* (1 940 kg)*												
+30 ft (9 m)	42 ft 0 in (12.7 m)	5,350 lb* (2 490 kg)*	5,350 lb* (2 490 kg)*												
+25 ft (7.5 m)	39 ft 7 in (12.0 m)	6,600 lb* (3 030 kg)*	6,600 lb* (3 030 kg)*												
+20 ft (6 m)	35 ft 9 in (10.8 m)	7,650 lb* (3 510 kg)*	7,650 lb* (3 510 kg)*												
+15 ft (4.5 m)	28 ft 10 in (8.62 m)	10,200 lb* (4 740 kg)*	10,200 lb* (4 740 kg)*										9,850 lb* (4 550 kg)*	9,850 lb* (4 550 kg)*	
+10 ft (3 m)	11 ft 4 in (3.46 m)	6,700 lb* (2 980 kg)*	6,700 lb* (2 980 kg)*					23,800 lb* (9 660 kg)*	23,800 lb* (9 660 kg)*	18,100 lb* (8 420 kg)*	18,100 lb* (8 420 kg)*	13,650 lb* (6 350 kg)*	13,650 lb* (6 350 kg)*	11,050 lb* (5 130 kg)*	11,050 lb* (5 130 kg)*
+5 ft (1.5 m)	11 ft 8 in (3.54 m)	4,150 lb* (1 880 kg)*	4,150 lb* (1 880 kg)*					10,850 lb* (4 630 kg)*	10,850 lb* (4 630 kg)*	21,000 lb* (9 750 kg)*	18,400 lb* (8 510 kg)	15,600 lb* (7 240 kg)*	13,650 lb* (6 320 kg)	12,350 lb* (5 730 kg)*	10,650 lb* (4 930 kg)
Groundline	9 ft 6 in (2.91 m)	3,700 lb* (1 680 kg)*	3,700 lb* (1 680 kg)*			4,000 lb* (1 770 kg)*	4,000 lb* (1 770 kg)*	9,300 lb* (4 070 kg)*	9,300 lb* (4 070 kg)*	20,500 lb* (8 850 kg)*	16,550 lb* (7 660 kg)	17,050 lb* (7 890 kg)*	12,300 lb* (5 710 kg)	13,450 lb* (6 230 kg)*	9,600 lb* (4 460 kg)
-5 ft (-1.5 m)	4 ft 10 in (1.49 m)	5,500 lb* (2 490 kg)*	5,500 lb* (2 490 kg)*	5,500 lb* (2 480 kg)*	5,500 lb* (2 480 kg)*	6,300 lb* (2 800 kg)*	6,300 lb* (2 800 kg)*	10,150 lb* (4 480 kg)*	10,150 lb* (4 480 kg)*	18,250 lb* (7 950 kg)*	15,450 lb* (7 180 kg)	17,950 lb* (8 290 kg)*	11,400 lb* (5 290 kg)	14,250 lb* (6 580 kg)*	8,900 lb* (4 120 kg)
-10 ft (-3 m)	2 ft 11 in (0.9 m)	7,350 lb* (3 300 kg)*	7,350 lb* (3 300 kg)*	7,400 lb* (3 330 kg)*	7,400 lb* (3 330 kg)*	8,450 lb* (3 780 kg)*	8,450 lb* (3 780 kg)*	11,850 lb* (5 240 kg)*	11,850 lb* (5 240 kg)*	18,600 lb* (8 160 kg)*	15,000 lb* (6 970 kg)	18,300 lb* (8 470 kg)*	10,900 lb* (5 060 kg)	14,650 lb* (6 780 kg)*	8,400 lb* (3 910 kg)
-15 ft (-4.5 m)	2 ft 1 in (0.65 m)	9,050 lb* (4 070 kg)*	9,050 lb* (4 070 kg)*	9,550 lb* (4 280 kg)*	9,550 lb* (4 280 kg)*	10,850 lb* (4 850 kg)*	10,850 lb* (4 850 kg)*	13,950 lb* (6 190 kg)*	13,950 lb* (6 190 kg)*	20,200 lb* (8 890 kg)*	14,950 lb* (6 950 kg)	18,250 lb* (8 440 kg)*	10,700 lb* (4 970 kg)	14,750 lb* (6 820 kg)*	8,150 lb* (3 800 kg)
-20 ft (-6 m)	2 ft 4 in (0.69 m)	10,900 lb* (4 890 kg)*	10,900 lb* (4 890 kg)*	11,800 lb* (5 270 kg)*	11,800 lb* (5 270 kg)*	13,400 lb* (5 980 kg)*	13,400 lb* (5 980 kg)*	16,550 lb* (7 340 kg)*	16,550 lb* (7 340 kg)*	22,550 lb* (9 990 kg)*	15,100 lb* (7 020 kg)	17,800 lb* (8 230 kg)*	10,700 lb* (4 980 kg)	14,500 lb* (6 710 kg)*	8,100 lb* (3 760 kg)
-25 ft (-7.5 m)	3 ft 7 in (1.04 m)	13,150 lb* (5 880 kg)*	13,150 lb* (5 880 kg)*	14,100 lb* (6 320 kg)*	14,100 lb* (6 320 kg)*	16,100 lb* (7 170 kg)*	16,100 lb* (7 170 kg)*	19,700 lb* (8 720 kg)*	19,700 lb* (8 720 kg)*	21,200 lb* (9 820 kg)*	15,450 lb* (7 180 kg)	16,950 lb* (7 850 kg)*	10,900 lb* (5 060 kg)	13,850 lb* (6 430 kg)*	8,200 lb* (3 810 kg)
-30 ft (-9 m)	6 ft 1 in (1.75 m)	16,300 lb* (7 220 kg)*	16,300 lb* (7 220 kg)*			19,100 lb* (8 480 kg)*	19,100 lb* (8 480 kg)*	23,300 lb* (10 290 kg)*	23,300 lb* (10 290 kg)*	19,250 lb* (8 950 kg)*	16,000 lb* (7 410 kg)	15,550 lb* (7 230 kg)*	11,250 lb* (5 210 kg)	12,750 lb* (5 950 kg)*	8,450 lb* (3 910 kg)
-35 ft (-10.5 m)	10 ft 3 in (2.95 m)	21,600 lb* (9 430 kg)*	21,600 lb* (9 430 kg)*			(9 520 kg)*	(9 520 kg)*	20,600 lb* (9 690 kg)*	20,600 lb* (9 690 kg)*	16,450 lb* (7 730 kg)*	16,350 lb* (7 620 kg)	13,400 lb* (6 310 kg)*	11,800 lb* (5 450 kg)	11,000 lb* (5 190 kg)*	8,850 lb* (4 100 kg)
-40 ft (-12 m)	18 ft 7 in (5.19 m)	13,200 lb* (6 690 kg)*	13,200 lb* (6 690 kg)*							12,500 lb* (6 010 kg)*	12,500 lb* (6 010 kg)*	10,200 lb* (4 920 kg)*	10,200 lb* (4 920 kg)*	8,250 lb* (4 000 kg)*	8,250 lb* (4 000 kg)*

NOTE: *Lift capacities do not exceed 75% of the minimum tipping load or 87% of the hydraulic lift capacity. Capacities that are marked with an asterisk are hydraulic limited.

LIFT CAPACITIES

25 ft 0 in (7.63 m) Arm Lift capacities calculated using a 1,320 lb (600 kg) bucket, 19,430 lb (8 810 kg) counterweight.

Load (Lift Point) Height	35 ft (10.5 m)		40 ft (12 m)		45 ft (13.5 m)		50 ft (15 m)		55 ft (16.5 m)		60 ft (18 m)		MAXIMUM REACH		
	END	SIDE	END	SIDE	END	SIDE	END	SIDE	END	SIDE	END	SIDE	@	END	SIDE
+45 ft (13.5 m)					(660 kg)*	(660 kg)*							45 ft 7 in (13.9 m)	(590 kg)*	(590 kg)*
+40 ft (12 m)					2,700 lb* (1 350 kg)*	2,700 lb* (1 350 kg)*	(660 kg)*	(660 kg)*					49 ft 2 in (15.1 m)	1,200 lb* (540 kg)*	1,200 lb* (540 kg)*
+35 ft (10.5 m)					3,850 lb* (1 860 kg)*	3,850 lb* (1 860 kg)*	2,450 lb* (1 310 kg)*	2,450 lb* (1 310 kg)*					52 ft 6 in (16.1 m)	1,150 lb* (520 kg)*	1,150 lb* (520 kg)*
+30 ft (9 m)					4,700 lb* (2 240 kg)*	4,700 lb* (2 240 kg)*	3,500 lb* (1 730 kg)*	3,500 lb* (1 730 kg)*	1,150 lb* (840 kg)*	1,150 lb* (840 kg)*			55 ft 1 in (16.9 m)	1,150 lb* (510 kg)*	1,150 lb* (510 kg)*
+25 ft (7.5 m)			6,600 lb* (3 030 kg)*	6,600 lb* (3 030 kg)*	5,600 lb* (2 650 kg)*	5,600 lb* (2 650 kg)*	4,350 lb* (2 080 kg)*	4,350 lb* (2 080 kg)*	2,400 lb* (1 330 kg)*	2,400 lb* (1 330 kg)*			57 ft 1 in (17.4 m)	1,150 lb* (520 kg)*	1,150 lb* (520 kg)*
+20 ft (6 m)			7,050 lb* (3 260 kg)*	7,050 lb* (3 260 kg)*	6,550 lb* (3 010 kg)*	6,400 lb* (2 960 kg)*	5,100 lb* (2 440 kg)*	5,100 lb* (2 440 kg)*	3,350 lb* (1 710 kg)*	3,350 lb* (1 710 kg)*			58 ft 6 in (17.9 m)	1,200 lb* (540 kg)*	1,200 lb* (540 kg)*
+15 ft (4.5 m)	8,550 lb* (3 950 kg)*	8,550 lb* (3 950 kg)*	7,650 lb* (3 520 kg)*	7,550 lb* (3 500 kg)*	6,950 lb* (3 190 kg)*	6,250 lb* (2 930 kg)	5,950 lb* (2 840 kg)*	4,950 lb* (2 320 kg)	4,050 lb* (2 040 kg)*	3,850 lb* (1 820 kg)	(750 kg)*	(750 kg)	59 ft 6 in (18.2 m)	1,250 lb* (570 kg)*	1,250 lb* (570 kg)*
+10 ft (3 m)	9,400 lb* (4 350 kg)*	9,300 lb* (4 300 kg)	8,250 lb* (3 800 kg)*	7,350 lb* (3 420 kg)	7,350 lb* (3 400 kg)*	5,800 lb* (2 720 kg)	6,650 lb* (3 090 kg)*	4,600 lb* (2 170 kg)	4,700 lb* (2 350 kg)*	3,600 lb* (1 710 kg)	1,400 lb* (990 kg)*	1,400 lb* (990 kg)*	60 ft 0 in (18.3 m)	1,350 lb* (620 kg)*	1,350 lb* (620 kg)*
+5 ft (1.5 m)	10,250 lb* (4 750 kg)*	8,400 lb* (3 910 kg)	8,850 lb* (4 080 kg)*	6,750 lb* (3 130 kg)	7,800 lb* (3 590 kg)*	5,400 lb* (2 520 kg)	7,000 lb* (3 230 kg)*	4,300 lb* (2 020 kg)	5,250 lb* (2 630 kg)*	3,400 lb* (1 610 kg)	1,600 lb* (1 100 kg)*	1,600 lb* (1 100 kg)*	60 ft 1 in (18.3 m)	1,550 lb* (690 kg)*	1,550 lb* (690 kg)*
Groundline	11,050 lb* (5 120 kg)*	7,700 lb* (3 570 kg)	9,400 lb* (4 340 kg)*	6,200 lb* (2 880 kg)	8,200 lb* (3 780 kg)*	5,000 lb* (2 330 kg)	7,250 lb* (3 340 kg)*	4,000 lb* (1 880 kg)	5,650 lb* (2 840 kg)*	3,200 lb* (1 510 kg)	(1 060 kg)*	(1 060 kg)*	59 ft 8 in (18.2 m)	1,700 lb* (780 kg)*	1,700 lb* (780 kg)*
-5 ft (-1.5 m)	11,700 lb* (5 140 kg)*	7,100 lb* (3 300 kg)	9,900 lb* (4 570 kg)*	5,750 lb* (2 670 kg)	8,500 lb* (3 940 kg)*	4,650 lb* (2 170 kg)	7,150 lb* (3 330 kg)	3,750 lb* (1 760 kg)	5,650 lb* (2 810 kg)	3,000 lb* (1 430 kg)			58 ft 10 in (17.9 m)	1,950 lb* (890 kg)*	1,950 lb* (890 kg)*
-10 ft (-3 m)	12,050 lb* (5 590 kg)*	6,700 lb* (3 120 kg)	9,900 lb* (4 590 kg)	5,400 lb* (2 520 kg)	8,250 lb* (3 830 kg)	4,400 lb* (2 050 kg)	6,950 lb* (3 230 kg)	3,550 lb* (1 680 kg)	5,100 lb* (2 740 kg)*	2,900 lb* (1 370 kg)			57 ft 6 in (17.6 m)	2,300 lb* (1 040 kg)*	2,300 lb* (1 040 kg)*
-15 ft (-4.5 m)	11,800 lb* (5 470 kg)	6,450 lb* (3 000 kg)	9,650 lb* (4 490 kg)	5,200 lb* (2 430 kg)	8,050 lb* (3 750 kg)	4,250 lb* (1 980 kg)	6,800 lb* (3 180 kg)	3,450 lb* (1 620 kg)	3,650 lb* (2 180 kg)*	2,850 lb* (1 340 kg)			55 ft 8 in (17.0 m)	2,750 lb* (1 230 kg)*	2,750 lb* (1 230 kg)*
-20 ft (-6 m)	11,700 lb* (5 430 kg)	6,350 lb* (2 960 kg)	9,550 lb* (4 450 kg)	5,100 lb* (2 380 kg)	8,000 lb* (3 720 kg)	4,150 lb* (1 950 kg)	6,800 lb* (3 160 kg)	3,450 lb* (1 610 kg)					53 ft 4 in (16.3 m)	3,350 lb* (1 500 kg)*	3,050 lb* (1 380 kg)
-25 ft (-7.5 m)	11,600 lb* (5 380 kg)*	6,400 lb* (2 980 kg)	9,600 lb* (4 460 kg)	5,150 lb* (2 400 kg)	8,050 lb* (3 740 kg)	4,200 lb* (1 960 kg)	4,600 lb* (2 850 kg)*	3,550 lb* (1 640 kg)					50 ft 3 in (15.4 m)	4,200 lb* (1 870 kg)*	3,500 lb* (1 570 kg)
-30 ft (-9 m)	10,650 lb* (4 980 kg)*	6,600 lb* (3 060 kg)	8,950 lb* (4 200 kg)*	5,300 lb* (2 470 kg)	7,400 lb* (3 500 kg)*	4,400 lb* (2 040 kg)							46 ft 4 in (14.3 m)	5,550 lb* (2 450 kg)*	4,200 lb* (1 880 kg)
-35 ft (-10.5 m)	9,150 lb* (4 330 kg)*	6,950 lb* (3 220 kg)	7,450 lb* (3 570 kg)*	5,650 lb* (2 610 kg)									41 ft 5 in (12.8 m)	6,950 lb* (3 160 kg)*	5,400 lb* (2 370 kg)
-40 ft (-12 m)	(3 250 kg)*	(3 250 kg)*											34 ft 11 in (10.9 m)	5,950 lb* (2 700 kg)*	5,950 lb* (2 700 kg)*

NOTE: *Lift capacities do not exceed 75% of the minimum tipping load or 87% of the hydraulic lift capacity. Capacities that are marked with an asterisk are hydraulic limited.

STANDARD EQUIPMENT

ENGINE

Isuzu AQ-6HK1X
Tier 4 Final Certified
Selective Catalytic Reduction – SCR
Diesel Oxidation Catalyst – DOC
Cooled Exhaust Gas Recirculation – CEGR
EGR Coolers
Six-cylinder turbo-charged diesel
VGT turbocharger
Electronic fuel injection
High pressure common rail system
Neutral safety start
Auto-engine warm up
Glow-plug pre-heat
Fuel Economy Assist System – FEA
Engine Protection Feature – EPF
Dual-stage fuel filtration
Dual element air filter
Remote oil filter
Drain for fuel tank
Remote engine oil drain
24 Volt system
Engine oil sample port
Battery disconnect switch
Air pre-cleaner – Cyclone
High ambient temperature cooling package
Emergency engine stop
External Fuel and DEF gauges
Fan housing
Fuel cooler
Fuel filter restriction indicator
Fuel shut-off valve
Idle start
Radiator, oil cooler,
intercooler – protective screen

FUEL ECONOMY SYSTEMS

Engine Idle/Fuel Economy System:
Auto-idle
One-touch idle
Auto-idle shut-down
BEC – Boom Economy Control
AEC – Auto Economy Control
SWC – Swing Relief Control
SSC – Spool Stroke Control

HYDRAULICS

Auto power boost
Auto swing priority
Arm speed assistance – 2 pump flow
Auxiliary flow control
Auxiliary valve
Boom speed assistance – 2 pump flow
Bucket curl assist
Control levers pre-wired for
auxiliary hydraulics
Electronically controlled hydraulic pumps
Holding valve – Boom and Arm
Fire wall
Hydraulic filter restriction indicator
Neutral pump de-stroke
Oil cooler

Power save
Pump stand-by pressure
Auto travel speed change
Selectable work modes
Free swing
Hydraulic oil sample port
Control pattern selector
Pre-set auxiliary pump settings
Auxiliary valve
SAHR brake

UPPER STRUCTURE

ISO mirrors – 3
Cab ISO-Mounts – fluid and spring
Upper mounted work light – 70 watt
Swivel guard belly pan
Center cover – over main CV
Fuel tank belly pan
Handrail – RH access
ISO guard rails
Lifting eyes for counterweight
Lockable fuel cap, service doors and toolbox

ATTACHMENTS

Boom – 35 ft 4 in (10.78 m)
Arm – 25 ft 0 in (7.63 m)
Heavy-duty bucket linkage
Auxiliary pipe brackets
Centralized grease fittings
Attachment cushion valve
Arm and boom regeneration
Bucket anti-clatter device
Chrome pins
Easy Maintenance System (EMS) bushings
Teardrop pin retention keepers

OPERATOR ENVIRONMENT

ROPS protection
FOPS cab top guard – Level 1
Pressurized cab
Face vent
Cab lights – 2
Interior dome light
One-touch lock front window
One piece window – right
Safety glass windows
Gate lock hydraulic activation
Emergency exit and hammer
Clear polycarbonate roof window
with sunshade
AC/heat/defrost with auto climate control
LED Color monitor – 7 in (180 mm)
26 selectable languages for monitor
On-board diagnostic system
10 programmable attachments settings on
monitor – 5 single flow, 5 dual flow
Seat belt – 3 in (76 mm)
Heated high-back cloth seat with air
suspension and 65° tilt adjustment
Sliding seat – 3.54 in (90 mm)

Adjustable armrests
Tilting consoles – 4-position
Sliding cockpit – 3.15 in (80 mm)
Low-effort joystick controls
Controls pre-wired for auxiliary
Single pedal travel
Straight travel
AM/FM radio with antenna, 2 speakers and
Bluetooth capabilities
Aux-in port for personal electronics
Radio mute switch – joystick
Rear-view camera
Anti-theft system – start code system
Rubber floor mat
12 Volt electric outlet
24 Volt cigarette lighter
Windshield wiper/washer
Cup holder
Storage compartments
Warm/cool storage compartment
Travel alarm with cancel switch
Ignition keys
One key start & lock-up
Cab filter – external
Cab handrails
Operator's manual

UNDERCARRIAGE

Long undercarriage
31.5 in (800 mm) steel shoes,
triple semi-grouser
Full overlap turntable bearing tub
Double track chain guides
Hydraulic track adjustment
Sealed link chain
Steps
Carbody belly pan – swivel guard
X-pattern carbody
Lashing points – tie downs

TELEMATICS

CASE SiteWatch™ Telematics – includes
hardware and a 3-yr Advanced
data subscription

OPTIONAL EQUIPMENT

ENGINE

Refueling pump

ATTACHMENTS

Tools:
Heavy-duty and Ditching Buckets.

UPPER STRUCTURE

Rubber bumper guard – order through
Service Parts
Catwalk – left and right side

UNDERCARRIAGE

33.5 in (850 mm) steel shoes,
triple semi-grouser

OPERATOR ENVIRONMENT

FOPS cab top guard – Level 2
Front grill guard – 2 x 2 in (50.8 x 50.8 mm)
screen mesh
Front rock guard – vertical bars
Two piece/OPG 1
Front rock guard – vertical bars
One piece/OPG 2
Vandal guard (front window) with
common key
Rain deflector – not available with
Front guards
Sun visor
Side-view camera
LED Package:
Includes 1 Side view camera and 6 LED
Lights – 2 front cab mounted, 2 rear
mounted and 1 mounted on each side

CaseCE.com

©2018 CNH Industrial America LLC. All rights reserved. CASE is a trademark registered in the United States and many other countries, owned by or licensed to CNH Industrial N.V., its subsidiaries or affiliates. CNH Industrial Capital is a trademark in the United States and many other countries, owned by or licensed to CNH Industrial N.V., its subsidiaries or affiliates. Printed in U.S.A. Contains 10% post-consumer fiber.

IMPORTANT: CASE Construction Equipment Inc. reserves the right to change these specifications without notice and without incurring any obligation relating to such change. Availability of some models and equipment builds vary according to the country in which the equipment is used. The illustrations and text may include optional equipment and accessories and may not include all standard equipment. Your CASE dealer/distributor will be able to give you details of the products and their specifications available in your area.



CASE Construction Equipment is biodiesel-friendly. NOTE: All engines meet current EPA emissions regulations. All specifications are stated in accordance with SAE Standards or Recommended Practices, where applicable.



Always read the Operator's Manual before operating any equipment. Inspect equipment before using it, and be sure it is operating properly. Follow the product safety signs and use any safety features provided.

Form No. CCE201808CX350DLR

CX350D LR

7 of 7