

ELECTRIC POWERTRAIN

Nominal Battery Voltage	102 Volts
Battery Chemistry	Lithium ion
Battery Capacity	21.5 kWh
Charge Time 20-80%:	
120V 1 phase - Onboard	8.5 hr
208V/480V 3 phase - Optional Offboard	1 hr
Charge Time 0-100%:	
120V 1 phase - Onboard	14 hr
208V/480V 3 phase - Optional Offboard	1.5 hr
Motor Type	Internal permanent magnet (IPM)
Motor Power	21 hp (16 kW)
Motor Speed:	
Eco Mode	2400 RPM
Standard Mode	2600 RPM
Power Mode	2800 RPM

TRACK DRIVE

Max Travel Speed:	
Turtle	1.1 mph (1.8 kph)
Rabbit	2.4 mph (3.8 kph)
Traction force	2,200 lbf (1 000 daN)
Gradeability	30° (60%)
Ground Pressure	4.6 psi (0.32 kg/cm ²)

OPERATOR ENVIRONMENT

Tilttable Roll-bar (ROPS/TOPS); Optional canopy (FOPS Level 1); Vinyl seat w/ mechanical suspension; Height adjustable arm rests; Controls cut-out lever (safety lever); 2 in (51 mm) Seat belt; Bottle/cup holder; Keyed locks common w/ starting key; Document glove box; Slewing locking lever; Auxiliary electrical socket; Control Panel.

Controls:

Travel Levers; Travel foot pedals; EH joysticks for boom, arm, bucket, and swing; Emergency stop button; Boom swing roller switch; Horn; Auxiliary hydraulics roller; Ignition switch; Blade control lever.

Display includes:

Hydraulic Oil Temp; Machine hours; Time; Warning Indicators; Message area; Function Indicators; Work modes; Motor speed; Battery level indicator; Fast drive indicator; Equipment selection; Control mode.

OPERATING WEIGHT

Standard Arm & Roll Bar	3,130 lb (1 420 kg)
Standard Arm & Canopy	3,186 lb (1 445 kg)
Long Arm & Roll Bar	3,139 lb (1 424 kg)
Long Arm & Canopy	3,194 lb (1 449 kg)
Mechanical quick coupler	49 lb (22 kg)

NOTE: Weight includes bucket, 165 lb operator, fluids, full fuel tank.

SERVICE CAPACITIES

Hydraulic tank:	
Refill capacity	2.5 gal (9.5 L)
Total system	4.0 gal (15 L)

HYDRAULICS

Load Sensing w/ "Flow Sharing" control valve	
Pump type	Low noise helical gear pump
Pump displacement	0.62 in ³ (10.1 cc)
Total flow rate	7.4 gpm (28 L/min)
Operating Pressure	2,600 psi (180 bar)
Auxiliary flow:	
Aux. 1 – 1 or 2-way circuit:	
Max. Flow	7.4 gpm (28 L/min)
Max. Pressure	2,600 psi (180 bar)
Aux. 2 – 2-way circuit:	
Max. Flow	2.6 gpm (10 L/min)
Max. Pressure	2,600 psi (180 bar)
Swing Motor:	Hydraulic drive units w/ axial pistons
Travel Motor:	Variable displacement hydraulic orbital gear motors, Auto-Shift 2-speed transmission, and hydraulic released parking brake

OTHER SPECIFICATIONS

Swing speed	9.5 RPM
Rubber tracks dimensions	7.1 x 1.7 x 2.8 in (180 x 43 x 72 mm)
Boom:	
Swing	60° left/70° right
Length	5 ft 1 in (1.55 m)
Arm:	
Standard length	3 ft 4 in (1.02 m)
Long arm length	3 ft 9 in (1.15 m)
Sound Pressure Internal – ISO6396 – LpA:	
Canopy	72 dBA
Sound Power External – LwA	82 dBA

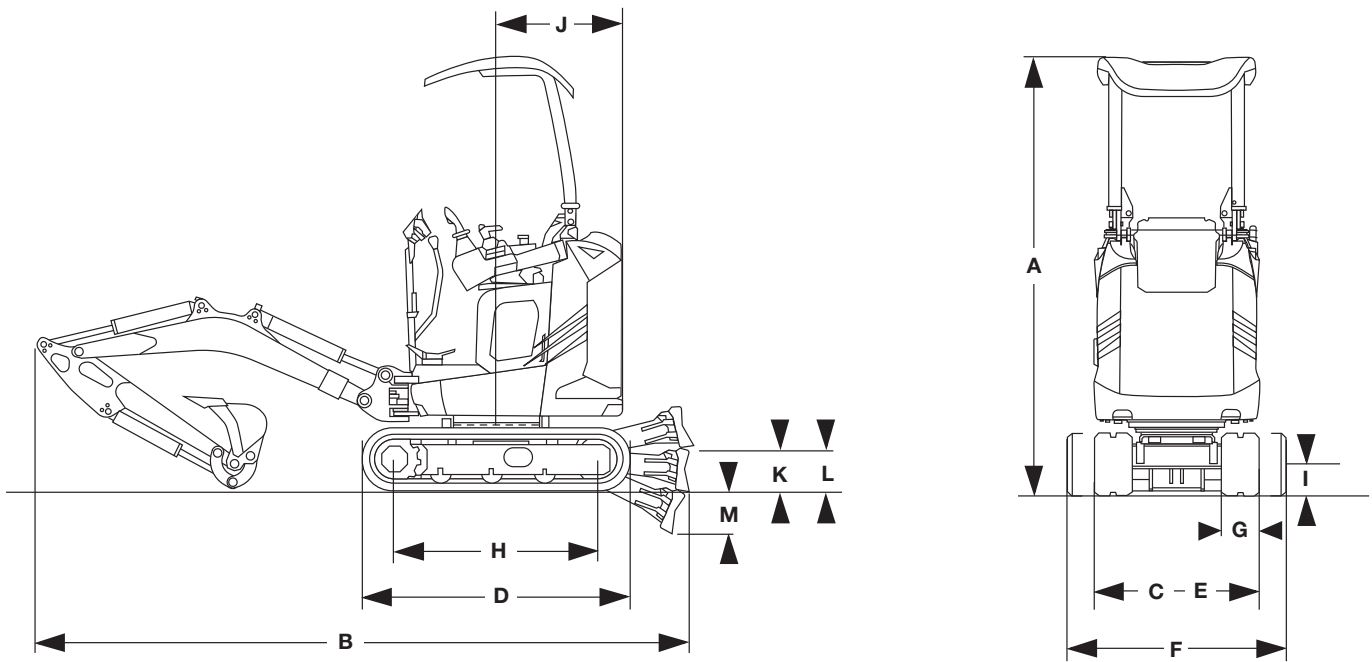

Line drawings are for illustrative purpose only and may not be exact representation of unit.

DIMENSIONS

3 ft 4 in (1.02 m) Arm

A. Overall height	7 ft 7 in (2 300 mm)
B. Overall transport length	10 ft 5 in (3 180 mm)
C. Width of upper structure	2 ft 7 in (790 mm)
D. Track overall length	4 ft 8 in (1 434 mm)
Track overall width:	
E. Tracks Retracted	2 ft 7 in (790 mm)
F. Tracks Extended	3 ft 5 in (1 050 mm)
G. Track shoe width	7 in (180 mm)
H. Center to center – idler to sprocket	3 ft 7 in (1 100 mm)
I. Minimum ground clearance	5.7 in (145 mm)
J. Tail swing radius:	
Standard counterweight	2 ft 4 in (710 mm)
Boom swing	60° left/70° right
Tail swing overhang:	
Tracks retracted	11 in (280 mm)
Tracks extended	6 in (150 mm)

BLADE SPECS

K. Backfill blade height	9 in (220 mm)
L. Backfill blade rise above ground	9 in (225 mm)
M. Backfill blade dig depth	9 in (225 mm)
Backfill blade width	2 ft 7 in (790 mm) - 3 ft 5 in (1 050 mm)

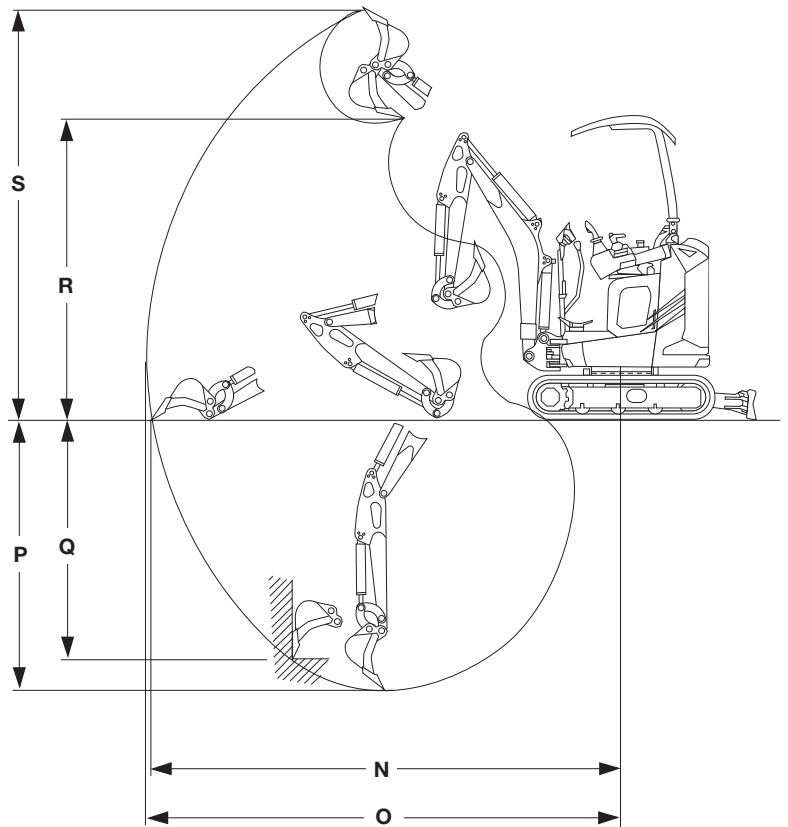

PERFORMANCE SPECS

	3 ft 4 in (1.02 m) Arm	3 ft 9 in (1.15 m) Arm
N. Maximum dig radius	12 ft 0 in (3 645 mm)	12 ft 4 in (3 755 mm)
O. Dig radius at groundline	11 ft 10 in (3 605 mm)	12 ft 2 in (3 715 mm)
P. Maximum dig depth	6 ft 9 in (2 045 mm)	7 ft 2 in (2 175 mm)
Q. Vertical straight wall dig depth	5 ft 11 in (1 805 mm)	6 ft 5 in (1 955 mm)
R. Dump height	7 ft 6 in (2 290 mm)	7 ft 10 in (2 380 mm)
S. Overall reach height	10 ft 5 in (3 115 mm)	10 ft 6 in (3 205 mm)
Arm digging force – ISO	1,400 lbf (630 daN)	1,304 lbf (580 daN)
Bucket digging force – ISO	2,600 lbf (1 150 daN)	2,600 lbf (1 150 daN)

LIFT CAPACITIES

5 ft 1 in (1.55 m) Boom, 3 ft 4 in (1.02 m) Arm, Dozer Blade Up Machine equipped with cab, rubber tracks, standard counterweight, without bucket or quick coupler.

Load/Lift Point Height	LOAD RADIUS										MAXIMUM REACH		
	3.3 ft (1.0 m)		4.9 ft (1.5 m)		6.6 ft (2.0 m)		8.2 ft (2.5 m)		9.8 ft (3.0 m)		REACH	CAPACITY	
	END	SIDE	END	SIDE	END	SIDE	END	SIDE	END	SIDE	@	END	SIDE
+8.2 ft (2.5 m)											7 ft 3 in (2.20 m)	617 lb (280 kg)*	463 lb (210 kg)
+6.6 ft (2.0 m)							551 lb (250 kg)	375 lb (170 kg)			8 ft 10 in (2.70 m)	485 lb (220 kg)	331 lb (150 kg)
+4.9 ft (1.5 m)							551 lb (250 kg)	375 lb (170 kg)			9 ft 10 in (3.00 m)	397 lb (180 kg)	265 lb (120 kg)
+3.3 ft (1.0 m)			948 lb (430 kg)*	816 lb (370 kg)	772 lb (350 kg)*	529 lb (240 kg)	551 lb (250 kg)	375 lb (170 kg)	419 lb (190 kg)	265 lb (120 kg)	10 ft 2 in (3.10 m)	397 lb (180 kg)	265 lb (120 kg)
+1.6 ft (0.5 m)			1,124 lb (510 kg)	705 lb (320 kg)	728 lb (330 kg)	485 lb (220 kg)	529 lb (240 kg)	331 lb (150 kg)	397 lb (180 kg)	265 lb (120 kg)	10 ft 6 in (3.20 m)	353 lb (160 kg)	220 lb (100 kg)
Groundline			1,080 lb (490 kg)	683 lb (310 kg)	705 lb (320 kg)	441 lb (200 kg)	507 lb (230 kg)	331 lb (150 kg)	397 lb (180 kg)	243 lb (110 kg)	10 ft 6 in (3.20 m)	353 lb (160 kg)	220 lb (100 kg)
-1.6 ft (0.5 m)		1,345 lb (610 kg)	1,080 lb (490 kg)	661 lb (300 kg)	683 lb (310 kg)	441 lb (200 kg)	485 lb (220 kg)	309 lb (140 kg)			9 ft 10 in (3.00 m)	375 lb (170 kg)	243 lb (110 kg)
-3.3 ft (1.0 m)		1,367 lb (620 kg)	970 lb (440 kg)*	683 lb (310 kg)	683 lb (310 kg)*	441 lb (200 kg)	485 lb (220 kg)*	331 lb (150 kg)			8 ft 10 in (2.70 m)	375 lb (170 kg)*	287 lb (130 kg)
-4.9 ft (1.5 m)			639 lb (290 kg)*	639 lb (290 kg)*	441 lb (200 kg)*	441 lb (200 kg)*					7 ft 3 in (2.20 m)	353 lb (160 kg)*	353 lb (160 kg)*

NOTE: Lifting capacity are based on ISO 10567.

Lifting capacity does not exceed 75% of tipping load with the machine on firm, level ground or 87% of full hydraulic capacity.

Back of the arm linkage.

*Indicates load limited by hydraulic capacity.

For lift capacities with additional counterweights please see operators manual.

5 ft 1 in (1.55 m) Boom, 3 ft 9 in (1.15 m) Arm, Dozer Blade Up Machine equipped with cab, rubber tracks, additional counterweight, without bucket or quick coupler.

Load/Lift Point Height	LOAD RADIUS										MAXIMUM REACH		
	3.3 ft (1.0 m)		4.9 ft (1.5 m)		6.6 ft (2.0 m)		8.2 ft (2.5 m)		9.8 ft (3.0 m)		REACH	CAPACITY	
	END	SIDE	END	SIDE	END	SIDE	END	SIDE	END	SIDE	@	END	SIDE
+8.2 ft (2.5 m)											7 ft 10 in (2.40 m)	551 lb (250 kg)*	397 lb (180 kg)
+6.6 ft (2.0 m)									507 lb (230 kg)*	375 lb (170 kg)	9 ft 2 in (2.80 m)	463 lb (210 kg)	309 lb (140 kg)
+4.9 ft (1.5 m)							529 lb (240 kg)*	375 lb (170 kg)	397 lb (180 kg)	265 lb (120 kg)	10 ft 2 in (3.10 m)	375 lb (170 kg)	243 lb (110 kg)
+3.3 ft (1.0 m)					661 lb (300 kg)*	529 lb (240 kg)	551 lb (250 kg)	375 lb (170 kg)	419 lb (190 kg)	265 lb (120 kg)	10 ft 10 in (3.30 m)	353 lb (160 kg)	220 lb (100 kg)
+1.6 ft (0.5 m)			1,146 lb (520 kg)	728 lb (330 kg)	728 lb (330 kg)	485 lb (220 kg)	507 lb (230 kg)	331 lb (150 kg)	397 lb (180 kg)	243 lb (110 kg)	10 ft 10 in (3.30 m)	331 lb (150 kg)	220 lb (100 kg)
Groundline			1,080 lb (490 kg)	683 lb (310 kg)	705 lb (320 kg)	441 lb (200 kg)	507 lb (230 kg)	331 lb (150 kg)	375 lb (170 kg)	243 lb (110 kg)	10 ft 10 in (3.30 m)	331 lb (150 kg)	220 lb (100 kg)
-1.6 ft (0.5 m)	2,249 lb (1 020 kg)*	1,323 lb (600 kg)	1,058 lb (480 kg)	661 lb (300 kg)	683 lb (310 kg)	441 lb (200 kg)	485 lb (220 kg)	309 lb (140 kg)	375 lb (170 kg)	243 lb (110 kg)	10 ft 2 in (3.10 m)	353 lb (160 kg)	220 lb (100 kg)
-3.3 ft (1.0 m)	1,830 lb (830 kg)*	1,345 lb (610 kg)	1,036 lb (470 kg)*	661 lb (300 kg)	683 lb (310 kg)	441 lb (200 kg)	485 lb (220 kg)	309 lb (140 kg)			9 ft 6 in (2.90 m)	353 lb (160 kg)*	265 lb (120 kg)
-4.9 ft (1.5 m)			750 lb (340 kg)*	683 lb (310 kg)	507 lb (230 kg)*	441 lb (200 kg)					7 ft 10 in (2.40 m)	331 lb (150 kg)*	331 lb (150 kg)*

NOTE: Lifting capacity are based on ISO 10567.

Lifting capacity does not exceed 75% of tipping load with the machine on firm, level ground or 87% of full hydraulic capacity.

Back of the arm linkage.

*Indicates load limited by hydraulic capacity.

For lift capacities with additional counterweights please see operators manual.

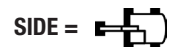
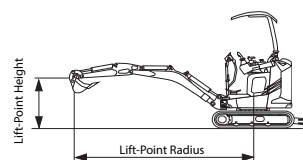

STANDARD EQUIPMENT

ELECTRICAL

12-volt electrical system
Heavy-duty battery
Ignition key, which opens every machine lock
Horn
Electronic display and controls
3 pre-set Control modes
Electronic flow setting for every mode and auxiliary circuits
On-board battery charger (120 VAC)
Control pattern mode

HYDRAULICS

Joysticks with Electro-Hydraulic proportional controls
Electro-Hydraulic proportional swing control
1st Auxiliary (AUX1) circuit with Electro-Hydraulic proportional control
Boom Lift cylinder and dozer blade cylinder protection
Helical Gear Pump
Bio-hydraulic oil and lubricants

TRACK DRIVE

Rubber belt tracks
2-speed travel with Automatic Shift Down (from 2nd to 1st gear if more traction is required) and Shift Up
Fully hydrostatic drive system
Sealed and lubricated track rollers
Track Tensioner Hydraulic adjustment with grease

LIGHTING

Standard LED working lights (boom)

UPPER STRUCTURE

Standard arm: 3 ft 4 in (1.02 m)
Standard Dozer Blade

OPERATOR ENVIRONMENT

See page 1

OTHER

Swing boom – 60° left/70° right
Standard counterweight
Extendable undercarriage
Operator manual
Document box and Tool kit for maintenance

TELEMATICS

CASE SiteWatch™ Telematics – includes hardware and a 5-yr Advanced data subscription for 2-way communication

WARRANTY

Base warranty coverage: 2-Year/3,000-Hour Full Machine Limited Warranty

OPTIONAL EQUIPMENT

OPERATOR ENVIRONMENT

Canopy (FOPS Level 1)

ELECTRICAL

Offboard Fast-Charger

VISIBILITY

Extra LED working lights (roof)
Rotating beacon

HYDRAULICS

2nd Auxiliary (AUX2) circuit with Electro-Hydraulic proportional control

OTHER

Optional long arm: 3 ft 9 in (1.15 m)

ATTACHMENTS

Mechanical quick coupler
Digging buckets

CaseCE.com

©2023 CNH Industrial America LLC. All rights reserved. CASE is a trademark registered in the United States and many other countries, owned by or licensed to CNH Industrial N.V., its subsidiaries or affiliates. CNH Industrial Capital is a trademark in the United States and many other countries, owned by or licensed to CNH Industrial N.V., its subsidiaries or affiliates. Printed in U.S.A. Contains 10% post-consumer fiber.

IMPORTANT: CASE Construction Equipment Inc. reserves the right to change these specifications without notice and without incurring any obligation relating to such change. Availability of some models and equipment builds vary according to the country in which the equipment is used. The illustrations and text may include optional equipment and accessories and may not include all standard equipment. Your CASE dealer/distributor will be able to give you details of the products and their specifications available in your area.



CASE Construction Equipment is biodiesel-friendly. NOTE: All engines meet current EPA emissions regulations. All specifications are stated in accordance with SAE Standards or Recommended Practices, where applicable.



Always read the Operator's Manual before operating any equipment. Inspect equipment before using it, and be sure it is operating properly. Follow the product safety signs and use any safety features provided.

Form No. CCE202303CX15EV

CX15EV

4 of 4