



## ENGINE

Model	FPT F5HFL463D
Emissions Certification	Tier 4 Final
Type	Diesel, 4-stroke, turbocharged
Cylinders	4
Bore/Stroke	3.9 in x 4.33 in (99 mm x 110 mm)
Displacement	207 in <sup>3</sup> (3.4 L)
Fuel injection	Direct high pressure common rail
Fuel	Diesel
Cooling	Charged air
Engine speeds*	RPM
Rated speed, full load	2200
Low idle	900 - 1000
High idle, no load	2330 - 2430
Horsepower @ 2200 RPM:	
Gross	74 hp (55 kW)
Net	68 hp (51 kW)
Maximum torque @ 1400 RPM:	
Gross	233 lb-ft (316 N-m)
Net	220 lb-ft (298 N-m)
Torque rise at rated speed	35% +/- 5%
Radiator:	
Core size area	486 in <sup>2</sup> (3 145 cm <sup>2</sup> )
Rows of tubes	5
33° fan:	
Style	7 blade suction
Ratio	1.1:1
Engine oil	CJ-4 – semi-synthetic 10W40
Pump operating angle ratings:	
Side-to-side	Rated 35°
Fore and aft	Rated 35°
Oil filtration	Replaceable, spin-on

NOTE: \*Meets federal emission regulations.

## DRIVETRAIN

Transmission – standard:  
4F-4R Power Shuttle  
Synchronesh Transmission manual gear shift  
fully synchronized

Gear ratios	Forward/Reverse
1st	5.603/5.603
2nd	3.481/3.481
3rd	1.584/1.584
4th	0.793/0.793
Travel speeds	mph (kph)
1st	3.8 (6.1)
2nd	6.1 (9.8)
3rd	12.8 (20.6)
4th*	24.0 (38.6)
Torque converter ratio	3.01
Differential lock	On-the-go push-button activation
Drive/steer axle:	
Differential ratio	2.5/2.0
Planetary hub ratio	6.4/6.0
Total reduction ratio	16.0/12.0

Service brakes:  
Individually applied, hydraulically actuated,  
outboard mounted, wet disc, 2 per side

Parking brakes Transmission Mounted  
spring applied hydraulic  
release – SAHR

NOTE: \*Travel speeds at 2330 engine RPM  
w/ 19.5 L x 24 tires.

## ELECTRICAL

Voltage	12 Volts
Alternator	120 amp
Battery	950 cold-cranking amps
Power plugs – 2	30 amps total

## OPERATOR ENVIRONMENT

ROPS/FOPS certified protective canopy; Wide  
walk through platform; Vinyl seat; 3 in (76 mm)  
seat belt; Molded front fenders; Rearview mirrors,  
left and right.

Gauges:  
Hour meter; Engine RPM; Engine coolant  
temperature; Transmission oil temperature;  
Job timer; Fuel level.

Warning lights:  
Air cleaner restriction; Alternator; Cold start;  
Engine oil pressure; Hydraulic oil filter  
bypass; Parking brake engagement; Engine  
coolant temp; Battery voltage.

Audible alarms:  
Coolant temperature; Engine oil pressure;  
Parking brake engagement; Converter oil  
temperature; Backup; Horn.

## OPERATING WEIGHT

### Configuration 1 – Lightest:

14,621 lb (6 206 kg)  
2WD, 15 ft Std. Mast, 48 in forks

### Configuration 2 – Heaviest:

14,621 lb (6 632 kg)  
4WD, 22 ft Std. Mast, 48 in forks

### Add-on weights:

Masts:	
15 ft Std. Mast	1,863 lb (845 kg)
22 ft Std. Mast	2,608 lb (1 183 kg)
Carriage – 60 in	110 lb (50 kg)
Forks:	
Hook style	322 lb (146 kg)
Shaft style	298 lb (135 kg)

## HYDRAULICS

Pump	Gear pump
Capacity	18 gal/min @ 3,000 psi (68 L/min @ 207 bar)

## SERVICE CAPACITIES

Fuel tank	31 gal (119 L)
Hydraulic system:	
Total	74 qt (70 L)
Reservoir w/ filter	58 qt (55 L)
Reservoir w/o filter	56 qt (53 L)
Transmission:	
2WD:	
Total	19.5 qt (18.5 L)
Reservoir	12.6 qt (11.9 L)
4WD:	
Total	22.0 qt (20.8 L)
Reservoir	15.2 qt (14.4 L)
Front axle:	
Differential and Planetaries	14.4 qt (13.6 L)
Rear axle:	
Differential and Planetaries	5.8 qt (5.5 L) 0.7 qt (0.7 L)
Engine oil w/ filter	8.5 qt (8.0 L)
Cooling system	18.3 qt (17.3 L)

## OTHER SPECIFICATIONS

### Mast:

Lift capacity to full height w/ 24 in load center:	
15 ft Std. Mast	6,000 lb (2 722 kg)
22 ft Std. Mast	3,000 lb (1 361 kg)
Mast type:	
15 ft Std. Mast	2 Stage Roller Mast
22 ft Std. Mast	3 Stage Roller Mast
Lift speed:	
15 ft Std. Mast	107 ft/min (0.55 m/s)
22 ft Std. Mast	112 ft/min (0.57 m/s)

### Tires:

Front:	
2/4WD	19.5 L x 24, 12-ply rating
Rear:	
2WD	11 L x 16, 10-ply rating
4WD	12 L x 16.5, 10-ply rating

### Turning diameter:

2WD:	
w/ brakes	21 ft 8 in (6.57 m)
w/o brakes	26 ft 1 in (7.93 m)
4WD – engaged:	
w/ brakes	20 ft 5 in (6.21 m)
w/o brakes	27 ft 10 in (8.47 m)
4WD – disengaged:	
w/ brakes	21 ft 6 in (6.61 m)
w/o brakes	26 ft 1 in (7.95 m)

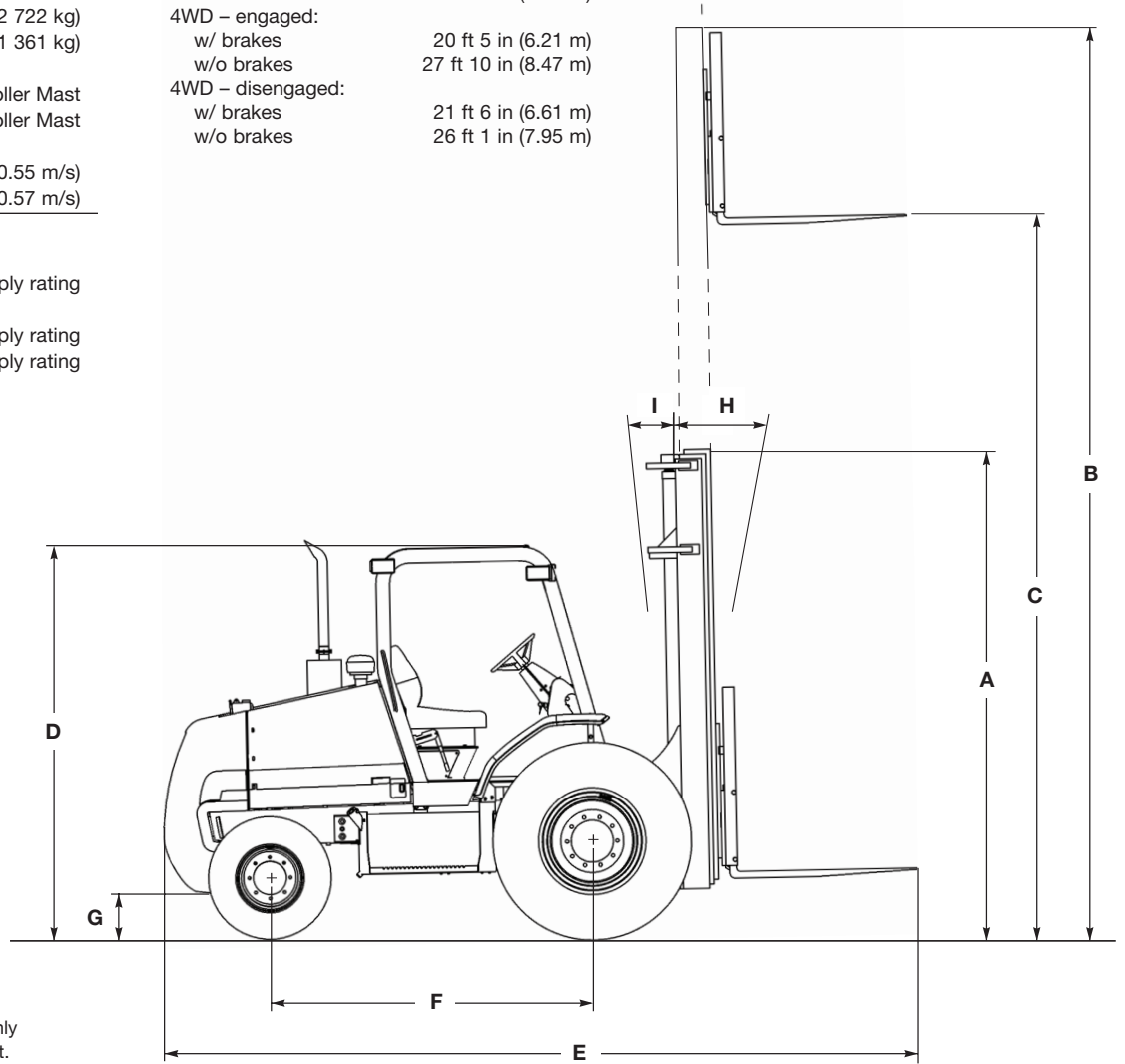

Line drawings are for illustrative purpose only and may not be exact representation of unit.

## DIMENSIONS

	15 ft (4.57 m) Std. Mast	22 ft (6.71 m) Std. Mast
<b>A.</b> Overall height to top of mast – mast closed	10 ft 7 in (3.23 m)	10 ft 7 in (3.23 m)
<b>B.</b> Overall operating height – mast raised to full height	18 ft 0 in (5.49 m)	25 ft 2 in (7.67 m)
<b>C.</b> Maximum fork height – forks horizontal	15 ft 0 in (4.57 m)	22 ft 0 in (6.71 m)
Maximum Freelifft fork height	3 in (76 mm)	2 in (51 mm)
<b>D.</b> Overall height to top of ROPS:		
19.5 L x 24, 12-ply	104.1 in (2 645 mm)	104.1 in (2 645 mm)
<b>E.</b> Overall length with 48 in forks	16 ft 2 in (4.93 m)	16 ft 3 in (4.95 m)
<b>F.</b> Wheelbase:		
2WD	84 in (2.13 m)	84 in (2.13 m)
4WD	84.5 in (2.15 m)	84.5 in (2.15 m)
<b>G.</b> Ground clearance:		
2WD	10.3 in (260 mm)	10.3 in (260 mm)
4WD	10.3 in (260 mm)	10.3 in (260 mm)
<b>H.</b> Forward mast tilt	45°	45°
<b>I.</b> Backward mast tilt	15°	15°
Overall width – outside tires	7 ft 0 in (2 117 mm)	7 ft 0 in (2 117 mm)
Mast side shift – right	3 in (76 mm)	3 in (76 mm)
Mast side shift – left	3 in (76 mm)	3 in (76 mm)

## STANDARD EQUIPMENT

### ENGINE

FPT 3.4 L Diesel  
Cooled EGR  
Diesel Oxidation Catalyst  
Full flow engine oil filter  
Air cleaner:  
    Replaceable dry type with radial seal  
Radiator with de-aeration bottle  
Antifreeze to -34°F (-37°C)  
Foot throttle  
Self adjusting belt  
Insulated CCV hose  
Glow Plugs  
Block Heater  
Pre Cleaner  
Master Disconnect Switch  
Remote Jump Start Terminals for Battery

### MAST

See page 1

## OPTIONAL EQUIPMENT

### MAST/FORKS/CARRIAGE

15 ft Standard Mast  
22 ft Standard Mast  
48 in Pallet Forks, ITA Class 3 hook type  
48 in Pallet Forks, shaft type  
60 in Backrest  
Other mast/fork/carriage combinations available through Special Feature

### DRIVETRAIN

Front axle, as selected:  
    2/4WD heavy-duty outboard planetary drive, with 19.5 L x 24 tires  
Rear axle:  
    2WD heavy-duty front axle with 11 L x 16 tires  
    4WD heavy-duty mechanically driven rear axle, with 12 L x 16.5 tires  
4F-4R Power Shuttle  
    Synchromesh Transmission  
Torque converter  
On-the-Go electric 4WD control  
Electric F/R shuttle control  
Electric differential lock control, with push-button activation  
Park brake, spring applied, hydraulic release

### HYDRAULICS

Heavy-duty hydraulic oil cooler  
7 micron, spin-on oil filter

### OPERATOR ENVIRONMENT

See page 1

### OTHER

Storage Compartment, lockable  
Swing out side panel engine access  
Front/rear tie downs  
Reflective logos  
Light Package:  
    2 front halogen driving lights  
    2 rear halogen work lights  
    1 rear tail/stop light  
    2 front turn signals  
    2 rear turn signals  
    Hazard warning

### HYDRAULICS

4 section valve for auxiliary hydraulics

### OPERATOR ENVIRONMENT

Load control  
Deluxe suspension seat, with lumbar support and high adjustments

### OTHER

Special paint  
Sitewatch Telematics

