



ENGINE

Model	Perkins 404F-E22TA
Emissions Certification	Stage 5 emissions
Type	Diesel 4-stroke, Turbo. D.I.
Cylinders	4
Bore/Stroke	3.31 x 3.94 in (84 x 100 mm)
Displacement	135.2 in ³ (2.2 L)
Fuel injection	Direct, high pressure common rail – HPCR
Fuel	#2 Diesel
Fuel filter:	
Pre-filter	Beta (30) = 200/spin on
Main filter	Beta (4) = 20/spin on
Air intake	Turbocharged w/ waste gate and intercooled w/ external EGR
Exhaust aftertreatment:	
	Diesel Oxidation Catalyst – DOC Diesel Particulate Filter – DPF
Cooling	Liquid
Engine speeds	RPM
High idle – no load	2825 +/- 25
Rated – full load	2800
Low idle	1200 +/- 50
Horsepower @ 2800 RPM – SAE J1349:	
Gross	60 hp (44.7 kW)
Net	57 hp (42.4 kW)
Peak torque @ 1800 RPM	153 lb-ft (208 N-m)
Radiator:	
Core type	Aluminum bar and plate
Core size area	265 in ² (0.171 m ²)
Rows of tubes	20
Cap pressure	16 +/- 2 psi (1.10 +/- 0.14 bar)
Fan:	
Diameter	17.7 in (450 mm)
Ratio	0.89:1
Water pump:	
Style	Centrifugal
Flow	14.7 gpm (55.5 L/min)
Engine lubrication pump	Pressure feed w/ Trichoid pump
Pump operating angle ratings:	
Side to side	35°
Bucket up	35°
Bucket Down	35°

LIFT GEOMETRY

Vertical Lift

DRIVETRAIN

Drive pump controls	Direct mechanical
Pump to engine ratio	1:1
Displacement	2.14 in ³ (35 cm ³)
Flow @ rated engine RPM:	
@ 97% efficiency	25.1 gpm (95 L/min)
Charge pressure	360 psi (24.5 bar)
System relief pressure	5,000 psi (345 bar)
Drive pump controls	Electro-hydraulic
Pump to engine ratio	1:1
Displacement	2.14 in ³ (35 cm ³)
Flow @ rated engine RPM:	
@ 97% efficiency	25.1 gpm (95 L/min)
Charge pressure	362 psi (24.5 bar)
System relief pressure	5,220 psi (360 bar)
Drive motors:	
Max. displacement	19.8 in ³ (325 cm ³)
Displacement:	
High speed	12.2 in ³ (200 cm ³)
Motor RPM @ high idle and 97% efficiency:	
2-speed	443
Motor torque @ max. displacement and relief pressure, calculated @ 5,000 psi (345 bar):	1,315 lb-ft (1 783 N-m)
Travel speed:	
Low range	7.4 mph (11.9 kph)
High range	10.8 mph (17.4 kph)
Final drive	Single-reduction chain drive
Drive chain:	
Size	ASA #80
Tensile strength	21,000 lb (93.4 kN)
Axles:	
Torque @ max. displacement and relief pressure	4,381 lb-ft (5 940 N-m)
Diameter	2.0 in (50.8 mm)
Length	15.1 in (384.0 mm)
Parking brake:	
Type	Spring-applied, hydraulic release multiple disc.
Engagement	Depress on/off brake button on handle or instrument panel, raise seat bar, get off seat or stop engine.

ELECTRICAL

Alternator	120 amp
Starter	2.68 hp (2.0 kW)
Battery	12-volt low-maintenance 950 cold-cranking amps @ 0° F (-18° C)

OPERATOR ENVIRONMENT

ROPS/FOPS Level 1 canopy w/ side screens;
Keyed start ignition; Tilt ROPS/FOPS; Rear
window w/ emergency escape; Suspension Seat,
vinyl w/ 2 in (51 mm) retractable 3 point lap seat
belt; Hand and foot throttle; Alarm package –
back-up and horn; Rearview mirror; Headliner;

Dome Light; Top window; Cup holder; 12V Power
plug socket; Foot rest; Seat pocket; Padded seat
bar w/ integral armrests; Loader control lockout
system; Electric parking brake control; Operator's
compartment floor cleanout; Proportional
auxiliary hydraulic control – on joystick; Advanced
Instrument Cluster w/ digital hour meter,
tachometer, fuel level LCD bar graph w/ alarm,
diagnostic features and security lockout.

Warning lights with alarms:

Engine coolant temperature; Engine oil pressure;
Engine malfunction; Hydraulic charge pressure;
Hydraulic filter restriction; Hydraulic oil
temperature: Critical system stop, Engine
system, Hydraulic system, Electrical and
diagnostic system.

Warning alarms:

Battery voltage – plus display; Oil service.

Indicator light:

Engine preheat; Parking brake;
Seat bar reminder.

OPERATING WEIGHT

Unit equipped w/ open cab; 165 lb operator;
66 in Dirt & Foundry bucket; full of fuel;
10 x 16.5 tires: 6,570 lb (2 980 kg)
Shipping weight 6,270 lb (2 840 kg)

Add-on weights:

Side cab glass 47 lb (21.3 kg)
Polycarbonate cab door 74 lb (33.6 kg)
Glass cab door w/ wiper 134 lb (60.8 kg)
Suspension seat 22 lb (10.0 kg)
Additional counterweight 140 lb (63.5 kg)

HYDRAULICS

Implement pump type	Gear
Displacement:	
Standard aux.	1.7 in ³ (27.8 cm ³)
High-flow aux.	0.84 in ³ (13.8 cm ³)
Standard flow @ rated engine RPM: @ 100% efficiency	20.6 gpm (78.0 L/min)
Optional high-flow @ rated engine RPM: @ 100% efficiency	30.7 gpm (116.2 L/min)
Loader control valve:	
Type	3 spool/open center/series - series
Relief pressure	3,050 psi (210 bar)
Port relief pressures:	
Loader raise	3,263 psi (225 bar)
Bucket curl	3,770 psi (260 bar)
Bucket dump	1,160 psi (80 bar)
Hydraulic lines:	
Tubing	37° JIC Flare
Loop hoses	SAE 100 R19
Hydraulic oil cooler:	
Number of fins	9.5 per inch (3.74 per cm)
Number of tube rows	7
Area	108 in ² (700 cm ²)
Hydraulic filter	Beta (4) = 75/spin-on

HYDRAULICS CONT.

Lift cylinders:	
Bore diameter	2.50 in (63.5 mm)
Rod diameter	1.75 in (44.45 mm)
Stroke	26.81 in (681 mm)
Closed length	38.66 in (982 mm)
Bucket cylinders:	
Bore diameter	2.50 in (63.5 mm)
Rod diameter	1.38 in (34.9 mm)
Stroke	16.14 in (410 mm)
Closed length	24.02 in (610 mm)

SERVICE CAPACITIES

Fuel tank	19.5 gal (73.8 L)
Engine oil w/ filter	7.5 qt (7.1 L)
Hydraulic system:	
Reservoir	4.3 gal (16.3 L)
Total	8.5 gal (32.2 L)
Chain tanks – per side	1.95 gal (7.4 L)

PERFORMANCE SPECS

Rated operating capacity – ROC*:	
50% of tipping load	1,850 lb (840 kg)
w/ additional counterweight	1,950 lb (885 kg)
Tipping load*	3,700 lb (1 678 kg)
Breakout forces @ 3,150 psi (217 bar)*:	
Bucket cylinders	5,550 lb (24.7 kN)
Lift cylinders – tip limit	3,450 lb (15.3 kN)
Cycle times:	
Raise	3.5 sec
Lower	2.3 sec
Dump	2.1 sec
Roll back	1.5 sec

NOTE: *Measured using 66 in (1.68 m) foundry/ excavating bucket.

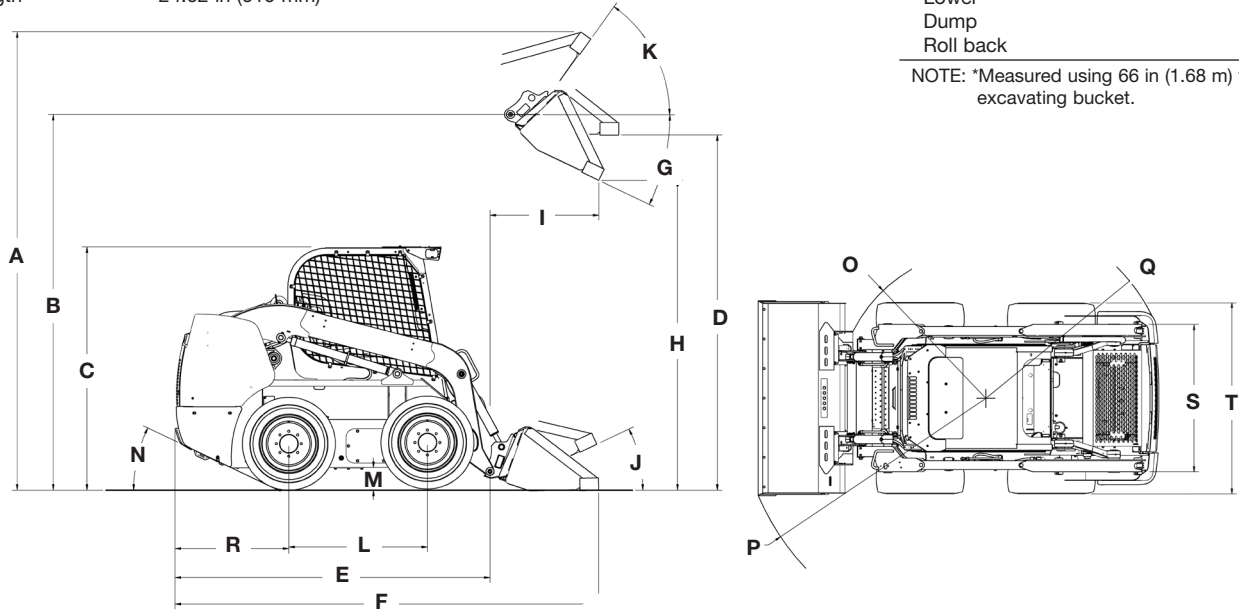

Line drawings are for illustrative purpose only and may not be exact representation of unit.

DIMENSIONS

A. Overall operating height:	
with foundry/excavating bucket	150.4 in (3.82 m)
with low profile bucket	154.6 in (3.93 m)
with low profile extended bucket	159.6 in (4.06 m)
Height to:	
B. Bucket hinge pin	120.0 in (3.05 m)
C. Top of ROPS	77.7 in (1.97 m)
D. Bottom of level bucket, fully raised	113.2 in (2.88 m)
Overall length:	
E. without attachment with coupler	105.7 in (2.69 m)
F. with foundry/excavating bucket on ground	131.7 in (3.34 m)
with low profile bucket	135.8 in (3.45 m)
with low profile extended bucket	140.9 in (3.58 m)
G. Maximum dump angle	51.9°
H. Dump height:	
with foundry/excavating bucket	93.7 in (2.38 m) @ 45°
with low profile bucket	90.7 in (2.31 m) @ 45°
I. Dump reach at maximum height with low profile bucket	33.7 in (0.86 m) @ 45°
Maximum attachment rollback:	
J. Bucket on ground	35°
K. Bucket at full height	87.6°
L. Wheelbase	44.4 in (1.13 m)
M. Ground clearance – bottom of belly pan	7.0 in (0.18 m)
N. Angle of departure	23.0°
Clearance circle:	
O. without bucket	53.0 in (1.35 m)
P. with 66 in (1.68 m) foundry/excavating bucket in carry position	80.2 in (2.04 m)
with 66 in (1.68 m) low profile bucket on ground	83.9 in (2.13 m)
with 66 in (1.68 m) extended low profile on ground	88.6 in (2.25 m)
Q. Clearance circle rear	62.9 in (1.60 m)
R. Rear axle to bumper	36.4 in (0.92 m)
S. Tread over gauge with spec lines	53.9 in (1.37 m)
T. Over the tire width spec tires	64.6 in (1.64 m)

OPTIONAL BUCKETS

Type	Width	Weight	Heaped Capacity
Dirt & Foundry	66 in (1.68 m)	385 lb (175 kg)	14.8 ft ³ (0.42 m ³)
	72 in (1.83 m)	420 lb (190 kg)	16.2 ft ³ (0.46 m ³)
	78 in (1.98 m)	440 lb (200 kg)	17.7 ft ³ (0.50 m ³)
Low Profile	66 in (1.68 m)	440 lb (200 kg)	13.4 ft ³ (0.38 m ³)
	72 in (1.83 m)	480 lb (218 kg)	14.8 ft ³ (0.42 m ³)
Low Profile Extended	66 in (1.68 m)	470 lb (214 kg)	15.9 ft ³ (0.45 m ³)
	72 in (1.83 m)	510 lb (232 kg)	17.7 ft ³ (0.50 m ³)
	78 in (1.98 m)	540 lb (245 kg)	19.1 ft ³ (0.54 m ³)
	84 in (2.13 m)	575 lb (262 kg)	20.5 ft ³ (0.58 m ³)
Light Material	72 in (1.83 m)	475 lb (216 kg)	23.3 ft ³ (0.66 m ³)
	84 in (2.13 m)	540 lb (245 kg)	27.5 ft ³ (0.78 m ³)
Manure & Slurry	72 in (1.83 m)	480 lb (218 kg)	19.1 ft ³ (0.54 m ³)
Heavy-Duty	72 in (1.83 m)	510 lb (230 kg)	14.1 ft ³ (0.40 m ³)
	78 in (1.98 m)	530 lb (240 kg)	15.5 ft ³ (0.44 m ³)
Heavy-Duty Extended with SmartFit Teeth	72 in (1.83 m)	667 lb (303 kg)	17.4 ft ³ (0.49 m ³)
	78 in (1.98 m)	697 lb (316 kg)	18.9 ft ³ (0.54 m ³)

STANDARD EQUIPMENT

OPERATOR ENVIRONMENT

See page 1

ENGINE

Charged Air Cooler (CAC)
Dual element air cleaner
Organic Acid Technology (OAT)
Anti-freeze solution to -34° F
Fuel tank – 20 gal (U.S.)
Over and under radiator and oil cooler
3-stack after cooler/radiator/oil cooler configuration
Glow plugs
Integral engine oil cooler
Fuel filter with water trap
925 CCA 12V battery
Master electrical disconnect

DRIVETRAIN

2-speed hydrostatic four wheel drive
ASA #80 drive chain
SAHR disc parking brake

HYDRAULICS

Auxiliary hydraulics:
@ 3,050 psi (210 bar) – 24.2 gpm
(91.5 L/min)
6 micron oil filtration system
3-spool loader control valve
Auxiliary hydraulic disconnects, ISO flat-face – connect-under-pressure with case drain
Hydraulic circuit pedal lock
Auxiliary function lockout override
Loader lift lockout override
Heavy-duty hydraulic oil cooler
Loader arm float position
Loader function lockout system

LOADER

Auxiliary front electric control
Manual attachment coupler
Vertical lift geometry
In-cab loader lock

TIRES

10 X 16.5 Heavy duty

OTHER STANDARD FEATURES

LED lights – 2 front, 2 side, 2 rear flood
Pre-wired for rotating beacon
Lockable service access hood
Single-point daily service
Rear tail lights
Remote oil and fuel filters
Block heater
Debris ingress sealing
Mounting points for add-on counterweights

TELEMATICS

CASE SiteWatch™ Telematics – includes hardware and a 5-yr data subscription
SiteConnect Module providing remote diagnostics capability

OPTIONAL AND FIELD INSTALLED EQUIPMENT

OPERATOR ENVIRONMENT

Enclosed cab:
Fully sealed and pressurized – FSP
Glass door with wiper and washer
Sliding side windows – removable
Heater and air conditioner
AM/FM Bluetooth radio with 2 speakers
Keyless start ignition
8 in Color LCD Display
Economy Mode (auto idle shutdown)
Auto Engine Protection Shutdown
Electro-hydraulic controls:
For drive/steering, loader functions
Switchable between H and ISO patterns
Adjustable sensitivity of controls
Mechanical hand controls
Hand and foot controls:
Hand controls the loader drive function and foot controls the bucket and boom
Deluxe cloth, air suspension seat, with heater and lumbar support
Demolition cab door with polycarbonate
Ignition Timeout
Machine Settings User Access Levels
Operator Security Codes
Auto Idle settings

HYDRAULICS

High-flow auxiliary hydraulics – combined:
@ 3,050 psi (210 bar) – 30.7 gpm
(116.2 L/min)
Hydraulic one-way self-leveling
Auto Ride Control
Ride control

LOADER

Hydraulic attachment coupler

DRIVETRAIN

Creep Speed Mode (on EH machines only)

OTHER

Language decals
Buckets – see page 3
Bolt-on bucket cutting edges
Special paint
Rotating beacon
4 Point Lift Hook

SERVICE PARTS

3 inch (76.2 mm) retractable seat belt
Bolt-on heavy-duty bucket teeth
Second auxiliary hydraulics
Add-on counterweights
Road lights
Four-corner LED strobe
Fire Extinguisher
Tamper Resistant Front Door Bracket
Bucket Cylinder Guards
Single Point Lift Hook
Aspirator
Attachment Hose Guide Kit
Drawbar

CaseCE.com

©2023 CNH Industrial America LLC. All rights reserved. CASE is a trademark registered in the United States and many other countries, owned by or licensed to CNH Industrial N.V., its subsidiaries or affiliates. CNH Industrial Capital is a trademark in the United States and many other countries, owned by or licensed to CNH Industrial N.V., its subsidiaries or affiliates. Printed in U.S.A. Contains 10% post-consumer fiber.

IMPORTANT: CASE Construction Equipment Inc. reserves the right to change these specifications without notice and without incurring any obligation relating to such change. Availability of some models and equipment builds vary according to the country in which the equipment is used. The illustrations and text may include optional equipment and accessories and may not include all standard equipment. Your CASE dealer/distributor will be able to give you details of the products and their specifications available in your area.



CASE Construction Equipment is biodiesel-friendly. NOTE: All engines meet current EPA emissions regulations. All specifications are stated in accordance with SAE Standards or Recommended Practices, where applicable.



Always read the Operator's Manual before operating any equipment. Inspect equipment before using it, and be sure it is operating properly. Follow the product safety signs and use any safety features provided.

Form No. CCE202310SV185B

Replaces Form No. CCE202103SV185B

SV185B

4 of 4