



ENGINE

Model	FPT F5H FL463 A*G001
Emissions Certification	Tier 4 Final
Type	Diesel, Turbo – Direct Injection
Cylinders	4
Bore/Stroke	3.9 x 4.3 in (99 x 110 mm)
Displacement	207 in ³ (3.4 L)
Fuel injection	Direct, high pressure common rail – HPCR
Fuel	#2 Diesel
Fuel filter:	
Pre-filter	Beta (30) = 200/spin-on
Main filter	Beta (4) = 20/spin-on
Air intake	Turbocharged w/ external EGR
Exhaust aftertreatment	Diesel Oxidation Catalyst – DOC
Cooling	Liquid
Engine speeds	RPM
High idle – no load	2500 +/- 25
Rated – full load	2500
Low idle	1150 +/- 25
Horsepower @ 2500 RPM – SAE J1349:	
Gross	74 hp (55 kW)
Net	68 hp (51 kW)
Peak torque @ 1400 RPM	232 lb-ft (314 N-m)
Radiator:	
Core type	All aluminum
Core size area	2.05 ft ² (0.191 m ²)
Rows of tubes x columns	31 x 4
Cap pressure	13 +/- 2 psi (0.90 +/- 0.14 bar)
Fan:	
Diameter	20.4 in (518 mm)
Ratio	0.96:1 standard, 1.1:1 high flow
Water pump:	
Style	Centrifugal
Flow	29 gpm (110 L/min)
Engine lubrication pump	Rotor pump w/ deep sump pan, plate cooler and pressurized under-piston nozzles
Pump operating angle ratings:	
Side to side	45°
Bucket up	35°
Bucket Down	45°

LIFT GEOMETRY

Vertical Lift

DRIVETRAIN

Drive pump controls	Servo-assist mechanical
Pump to engine ratio	1:1
Displacement	2.81 in ³ (46 cm ³)
Flow @ rated engine RPM:	
@ 97% efficiency	29.4 gpm (111 L/min)
Charge pressure	360 psi (24.5 bar)
System relief pressure	5,220 psi (360 bar)

Drive pump controls	Electro-hydraulic
Pump to engine ratio	1:1
Displacement	2.75 in ³ (45 cm ³)
Flow @ rated engine RPM:	
@ 97% efficiency	28.8 gpm (109 L/min)
Charge pressure	362 psi (25 bar)
System relief pressure	5,220 psi (360 bar)

Drive motors:	
Max. displacement	28.7 in ³ (470 cm ³)
Displacement:	
High speed	17.2 in ³ (282 cm ³)
Motor RPM @ high idle and 97% efficiency:	
2-speed	355
Motor torque @ max. displacement and relief pressure, calculated @ 5,220 psi (360 bar):	1,987 lb-ft (2 694 N-m)

Travel speed:	
Low range	7.0 mph (11.3 kph)
High range	10.5 mph (16.9 kph)

Final drive	Single-reduction chain drive
-------------	------------------------------

Drive chain:	
Size	ASA #100
Tensile strength	30,000 lb (133.4 kN)

Axles:	
Torque @ max. displacement and relief pressure	5,957 lb-ft (8 077 N-m)
Diameter	2.44 in (62 mm)
Length	15.6 in (396 mm)

Parking brake:	
Type	Spring-applied, hydraulic release multiple disc.
Engagement	Depress on/off brake button on handle or instrument panel, raise seat bar, get off seat or stop engine.

ELECTRICAL

Alternator	120 amp
Starter	4.29 hp (3.2 kW)
Battery	12-volt low-maintenance 925 cold-cranking amps @ 0° F (-18° C°)

OPERATOR ENVIRONMENT

ROPS/FOPS Level 1 canopy w/ side screens; Keyed start ignition; Tilt ROPS/FOPS; Rear window w/ emergency escape; Deluxe cloth, air suspension seat, w/ 2 in (51 mm) retractable 3 point lap seat belt, w/ heater and lumbar support; Hand and foot throttle; Alarm package – back-up

and horn; Rearview mirror; Headliner; Dome Light; Top window; Cup holder; 12V Power plug socket; Foot rest; Seat Pocket; Padded seat bar w/ integral armrests; Loader control lockout system; Electric parking brake control; Operator's compartment floor cleanout; Proportional auxiliary hydraulic control – on joystick; Advanced Instrument Cluster w/ digital hour meter, tachometer, fuel level LCD bar graph w/ alarm, diagnostic features and security lockout.

Warning lights with alarms:
Engine coolant temperature; Engine oil pressure; Engine malfunction; Hydraulic charge pressure; Hydraulic filter restriction; Hydraulic oil temperature; Critical system stop, Engine system, Hydraulic system, Electrical and diagnostic system.

Warning alarms:
Battery voltage – plus display; Oil service.

Indicator light:
Engine preheat; Parking brake;
Seat bar reminder.

OPERATING WEIGHT

Unit equipped w/ open cab; 165 lb operator;	
72 in Low Profile bucket; full of fuel;	
12 x 16.5 tires:	8,000 lb (3 630 kg)
Shipping weight	7,665 lb (3 475 kg)
Add-on weights:	
Side cab glass	47 lb (21.3 kg)
Polycarbonate cab door	75 lb (34.0 kg)
Glass cab door w/ wiper	75 lb (34.0 kg)
Suspension seat	22 lb (10.0 kg)
Additional counterweight	300 lb (136.0 kg)

HYDRAULICS

Implement pump type		Gear
Displacement:		
Standard aux.	2.23 in ³ (36.6 cm ³)	
High-flow aux.	1.24 in ³ (20.4 cm ³)	
Standard flow @ rated engine RPM: @ 100% efficiency	24.2 gpm (91.5 L/min)	
Optional high-flow @ rated engine RPM: @ 100% efficiency	37.6 gpm (142.5 L/min)	
Loader control valve:		
Type	3 spool/open center/series - series	
Relief pressure	3,046 psi (210 bar)	
Port relief pressures:		
Loader raise	3,263 psi (225 bar)	
Bucket curl	3,770 psi (260 bar)	
Bucket dump	1,160 psi (80 bar)	
Hydraulic lines:		
Tubing	37° JIC Flare	
Loop hoses	SAE 100 R19	

HYDRAULICS CONT.

Hydraulic oil cooler:	
Number of fins	10 per inch (3.94 per cm)
Number of tube rows x columns	11 x 2
Area	130.7 in ² (843.2 cm ²)

Hydraulic filter	Beta (4) = 75/spin-on
------------------	-----------------------

Lift cylinders:	
Bore diameter	2.75 in (69.85 mm)
Rod diameter	2.0 in (50.8 mm)
Stroke	34.9 in (886.5 mm)
Closed length	47.4 in (1 205 mm)

Bucket cylinders:	
Bore diameter	3.0 in (76.2 mm)
Rod diameter	1.5 in (38.1 mm)
Stroke	16.4 in (410 mm)
Closed length	24.0 in (610 mm)

SERVICE CAPACITIES

Fuel tank	25.5 gal (96.5 L)
Engine oil w/ filter	8.9 qt (8.5 L)

Hydraulic system:	
Reservoir	6.0 gal (22.7 L)
Total	11.99 gal (45.46 L)
Chain tanks – per side	5.8 gal (22.2 L)

PERFORMANCE SPECS

Rated operating capacity – ROC*:	
50% of tipping load	2,800 lb (1 270 kg)
w/ additional counterweight	2,900 lb (1 315 kg)

Tipping load*	5,600 lb (2 540 kg)
---------------	---------------------

Breakout forces @ 3,150 psi (217 bar)*:	
Bucket cylinders	8,776 lb (39.0 kN)
Lift cylinders – tip limit	6,011 lb (26.7 kN)

Cycle times:	
Raise	4.6 sec
Lower	3.5 sec
Dump	2.6 sec
Roll back	2.0 sec

NOTE: *Measured using 72 in (1.83 m) foundry/ excavating bucket.

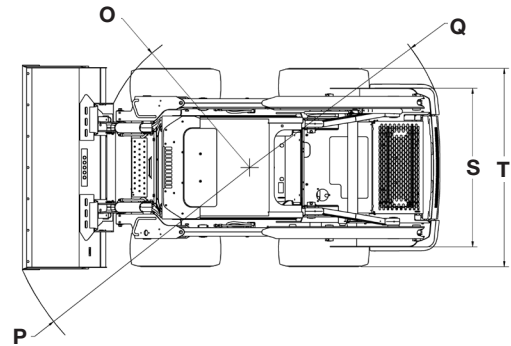
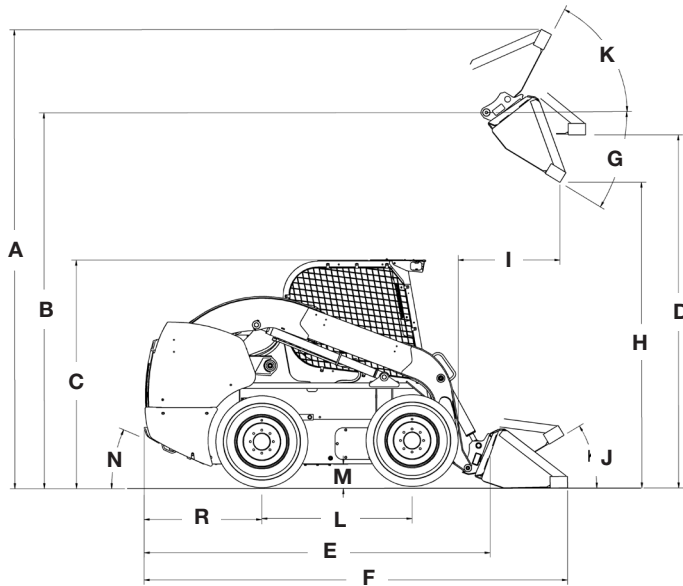

Line drawings are for illustrative purpose only and may not be exact representation of unit.

DIMENSIONS

A. Overall operating height:		
with foundry/excavating bucket		160.4 in (4.07 m)
with low profile bucket		164.4 in (4.18 m)
with low profile extended bucket		169.5 in (3.04 m)
Height to:		
B. Bucket hinge pin		130.0 in (3.30 m)
C. Top of ROPS		78.8 in (2.00 m)
D. Bottom of level bucket, fully raised		119.6 in (3.04 m)
Overall length:		
E. without attachment with coupler		117.7 in (2.99 m)
F. with foundry/excavating bucket on ground		141.9 in (3.60 m)
with low profile bucket		146.0 in (3.71 m)
with low profile extended bucket		151.0 in (3.84 m)
G. Maximum dump angle		53.5°
H. Dump height:		
with foundry/excavating bucket		103.5 in (2.63 m) @ 45°
with low profile bucket		100.6 in (2.56 m) @ 45°
I. Dump reach at maximum height with low profile bucket		29.3 in (0.74 m) @ 45°
Maximum attachment rollback:		
J. Bucket on ground		35.0°
K. Bucket at full height		86.0°
L. Wheelbase		52.0 in (1.32 m)
M. Ground clearance – bottom of belly pan		8.0 in (0.20 m)
N. Angle of departure		23.5°
Clearance circle:		
O. without bucket		55.7 in (1.42 m)
P. with 72 in (1.83 m) foundry/excavating bucket in carry position		84.1 in (2.14 m)
with 72 in (1.83 m) low profile bucket on ground		87.8 in (2.23 m)
with 72 in (1.83 m) extended low profile on ground		92.4 in (2.35 m)
Q. Clearance circle rear		70.4 in (1.79 m)
R. Rear axle to bumper		40.7 in (1.03 m)
S. Tread over gauge with spec tires		56.9 in (1.45 m)
T. Over the tire width spec tires		69.6 in (1.77 m)

OPTIONAL BUCKETS

Type	Width	Weight	Heaped Capacity
Dirt & Foundry	72 in (1.83 m)	420 lb (190 kg)	16.2 ft ³ (0.46 m ³)
	78 in (1.98 m)	440 lb (200 kg)	17.7 ft ³ (0.50 m ³)
Low Profile	72 in (1.83 m)	480 lb (218 kg)	14.8 ft ³ (0.42 m ³)
Low Profile Extended	72 in (1.83 m)	510 lb (232 kg)	17.7 ft ³ (0.50 m ³)
	78 in (1.98 m)	540 lb (245 kg)	19.1 ft ³ (0.54 m ³)
	84 in (2.13 m)	575 lb (262 kg)	20.5 ft ³ (0.58 m ³)
Light Material	72 in (1.83 m)	475 lb (216 kg)	23.3 ft ³ (0.66 m ³)
	84 in (2.13 m)	540 lb (245 kg)	27.5 ft ³ (0.78 m ³)
Manure & Slurry	72 in (1.83 m)	480 lb (218 kg)	19.1 ft ³ (0.54 m ³)
Heavy-Duty	72 in (1.83 m)	510 lb (230 kg)	14.1 ft ³ (0.40 m ³)
	78 in (1.98 m)	530 lb (240 kg)	15.5 ft ³ (0.44 m ³)
	84 in (2.13 m)	550 lb (250 kg)	17.0 ft ³ (0.48 m ³)
Heavy-Duty Extended with SmartFit Teeth	72 in (1.83 m)	667 lb (303 kg)	17.4 ft ³ (0.49 m ³)
	78 in (1.98 m)	697 lb (316 kg)	18.9 ft ³ (0.54 m ³)
	84 in (2.13 m)	728 lb (330 kg)	20.5 ft ³ (0.58 m ³)

STANDARD EQUIPMENT

OPERATOR ENVIRONMENT

See page 1

ENGINE

FPT F5H FL463 A*G001 diesel
207 CID (3.4 L) Turbo
Tier 4 Final Certified
Particulate Matter Catalyst
Charged Air Cooler (CAC)
High Pressure Common Rail (HPCR)
fuel injection
Horsepower:
Gross: 74 hp (55 kW)
Net: 68 hp (51 kW)
Peak torque: 232 lb-ft (314 N·m)
120 amp alternator
Dual element air cooler
Organic Acid Technology (OAT)
Anti-freeze solution to -34° F
Fuel tank – 25.5 gal (U.S.)
Over and under radiator and oil cooler
3-stack after cooler/radiator/oil
cooler configuration
Glow plugs

OPTIONAL EQUIPMENT

OPERATOR ENVIRONMENT

Enclosed cab:
Fully sealed and pressurized – FSP
Glass door with wiper and washer
Sliding side windows – removable
Heater and air conditioner
AM/FM Bluetooth radio with 2 speakers
Keyless start ignition
8 in Color LCD Display
Economy Mode (auto idle shutdown)
Auto Engine Protection Shutdown
Electro-hydraulic controls:
For drive/steering, loader functions
Switchable between H and ISO patterns
Adjustable sensitivity of controls
Mechanical hand controls
Hand and foot controls:
Hand controls the loader drive function
and foot controls the bucket and boom
Non suspension seat
Suspension Seat, vinyl with 2 in (51 mm)
retractable lap seat belt
Demolition cab door with polycarbonate
FOPS level 2

Integral engine oil cooler
Fuel filter with water trap
925 CCA 12V battery
Master electrical disconnect

DRIVETRAIN

2-speed hydrostatic four wheel drive
ASA #100HS drive chain
SAHR disc parking brake

HYDRAULICS

Auxiliary hydraulics:
@ 3,050 psi (210 bar) – 24.2 gpm
(91.5 L/min)
6 micron oil filtration system
3-spool loader control valve
Auxiliary hydraulic disconnects, ISO
flat-face – connect-under-pressure
with case drain
Hydraulic circuit pedal lock
Auxiliary function lockout override
Loader lift lockout override
Heavy-duty hydraulic oil cooler
Loader arm float position
Loader function lockout system

Ignition Timeout
Machine Settings User Access Levels
Operator Security Codes

HYDRAULICS

High-flow auxiliary hydraulics – combined:
@ 3,050 psi (210 bar) – 37.6 gpm
(142.5 L/min)
Second auxiliary hydraulics
Hydraulic one-way self-leveling
Ride control

LOADER

Hydraulic attachment coupler

DRIVETRAIN

Creep Speed Mode

LOADER

Auxiliary front electric control
Heavy duty hydraulic attachment coupler
Vertical lift geometry
Loader lift arm support strut
In-cab loader lock

TIRES

12 X 16.5 Heavy duty

OTHER STANDARD FEATURES

Halogen lights – 2 front, 2 side, 2 rear flood
Pre-wired for rotating beacon
Lockable service access hood
Single-point daily service
Rear tail lights
Remote oil drain
Remote oil and fuel filters
Block heater
Debris ingress sealing
Mounting points for add-on counterweights

OTHER

Language decals
Buckets – see page 3
Bolt-on bucket cutting edges
Special paint
Offsite service arrangement
Telematics

FACTORY SUPPLIED ATTACHMENTS

Add-on counterweights
Road lights
Rotating beacon
Four-corner LED strobe

SERVICE PARTS

3 inch (76.2 mm) retractable seat belt
Bolt-on heavy-duty bucket teeth

CaseCE.com

©2020 CNH Industrial America LLC. All rights reserved. CASE is a trademark registered in the United States and many other countries, owned by or licensed to CNH Industrial N.V., its subsidiaries or affiliates. CNH Industrial Capital is a trademark in the United States and many other countries, owned by or licensed to CNH Industrial N.V., its subsidiaries or affiliates. Printed in U.S.A. Contains 10% post-consumer fiber.

IMPORTANT: CASE Construction Equipment Inc. reserves the right to change these specifications without notice and without incurring any obligation relating to such change. Availability of some models and equipment builds vary according to the country in which the equipment is used. The illustrations and text may include optional equipment and accessories and may not include all standard equipment. Your CASE dealer/distributor will be able to give you details of the products and their specifications available in your area.



CASE Construction Equipment is biodiesel-friendly. NOTE: All engines meet current EPA emissions regulations. All specifications are stated in accordance with SAE Standards or Recommended Practices, where applicable.



Always read the Operator's Manual before operating any equipment. Inspect equipment before using it, and be sure it is operating properly. Follow the product safety signs and use any safety features provided.

Form No. CCE202001SV280B
Replaces Form No. CCE201911SV280B

SV280B

4 of 4