



ENGINE

Model	FPT F5H FL463 A
Emissions Certification	Tier 4 Final
Type	4-stroke
Cylinders	4
Bore/Stroke	3.9 x 4.3 in (99 x 110 mm)
Displacement	207 in ³ (3.4 L)
Fuel injection	High pressure, common rail injection
Fuel	Diesel
Fuel filter	Spin on, Beta (4) = 20
Air filter	Dry type element w/ warning restriction indicator
Exhaust aftertreatment:	Cooled Exhaust Gas Recirculation (CEGR) w/ Diesel Oxidation Catalyst (DOC)
Radiator:	
Core type	All aluminum
Fan:	
Style	Direct drive
Lubrication/cooling oil pump:	
Style	Integral
Engine oil:	
Pump:	Rotor Pump w/ deep sump pan, plate cooled & pressurized under piston nozzles
Pump operating angle ratings:	
Side-to-side	Rated 35°
Fore and aft	Rated 35°
Oil filtration	Spin on, full flow
Engine speeds	RPM
Rated – full load	2500
Low idle	950
High idle – no load	2500
Horsepower @ 2500 RPM:	
Gross	74 hp (55 kW)
Net	70 hp (52 kW)
Peak torque @ 1400 RPM:	
Gross	232 lb-ft (314 N-m)
Net	227 lb-ft (308 N-m)

NOTE: Gross horsepower and torque per SAE J1349.
Net horsepower and torque per SAE J1349.

DRIVETRAIN

Transmission	Hydrostatic transmission	
Pump relief	6,092 psi (42 000 kPa)	
Pump flow @ 2500 RPM	37.0 gpm (140 L/min)	
Differential:	Open standard/limited slip or 100% lock opt.	
Front axles:		
Differential ratio	3.67	
Planetary ratio	6.00	
Final axle ratio	22.00	
Gear box:		
1st ratio	2.46	
Gear box HS:		
1st ratio	2.75	
2nd ratio	1.16	
Planetaries	Outboard	
Service brakes:	Master cylinder hydraulically actuated, wet disc on front axle	
Parking brake:	Mechanical, caliper on front axle	
Travel speeds	Forward	Reverse
	mph (kph)	mph (kph)
1st Low	3.3 (5.3)	3.3 (5.3)
2nd High	11.4 (18.3)	11.4 (18.3)
Travel speeds – HS	Forward	Reverse
	mph (kph)	mph (kph)
1st Low	3.0 (4.8)	3.0 (4.8)
2nd High	8.1 (13.0)	8.1 (13.0)
3rd High	18.6 (30.0)	18.6 (30.0)

NOTE: Travel speeds at full engine throttle
w/ 365/80 R18 tires.

ELECTRICAL

Voltage	12 Volts
Alternator	120 amp
Batteries	95 AHR, 900 CCA

OPERATOR ENVIRONMENT

ROPS: ISO 3471: 2,008 lb (6 800 kg); Base and Deluxe Cab w/ heater and A/C; Key start; Articulated power steering w/ tilt column; Full adjustable, cloth suspension seat; Foot throttle; Single joystick w/ electronic speed shift control F/N/R switch and proportional loader control; Cup holder; Retractable seat belt; Storage tray on Deluxe Cab; Sun screen – front; Opening side window; Dome light; Wipers – front and rear; 12-volt auxiliary power; Lighter cigar and ashtray; Pocket cellular phone; Coat hook; External rearview mirrors; Loader control lockout.

Electronic information center

Displays/Gauges:

Vehicle speed; Hourmeter; Floating functionality on; High flow functionality on; Clock; Vehicle directions; Gear number engaged; PM Catalyst icons.

Indicator lights:

Diff. lock; Main hydraulic enabled; Turn light – left and right; Rear work lamps; Work lamps; Main high beam; Side lights; Stop; Warning signal; Rabbit; Hand brake; Brake fluid level; Quick coupler on; Ride Control on; Creep speed; PM Catalyst; Low fuel level; Clogging air filter; Engine oil pressure; Glow plug; Alternator changing.

Audible alarms:

Caution alarm; Critical alarm; Backup alarm.

Horn

NOTE: If equipped w/ option.

OPERATING WEIGHT

Z-Bar:

Unit equipped w/ ROPS/FOPS cab w/ heater, standard counterweight, 365/70 R18 Dunlop Tires, front and rear fenders, 1.2 yd³ (0.9 m³) general purpose bucket w/ edge, full fuel, 165 lb (75 kg) operator:

12,547 lb (5 691 kg)

HYDRAULICS

Pump – steering/implement:

Open-centered pressure/flow compensated

Fixed gear type:

Standard flow:

Max. 22.5 gpm @ 3,336 psi
(Max. 85 L/min @ 230 bar)

Optional high flow:

Max. 34.3 gpm @ 2,901 psi
(Max. 130 L/min @ 230 bar)

Loader control valve:

Open-center, Hydraulic Loader Control w/ single lever includes: Forward/Neutral/Reverse switch, Floating switch, Low/High Travel mode switch, Auxiliary Function Roller

Loader auxiliary steering:

Hydraulic orbital center-pivot articulating w/ on-demand oil flow

Main relief pressure 3,336 psi (23 000 kPa)

Filtration:

15-micron, full flow replaceable cartridges on return line

SERVICE CAPACITIES

Fuel tank	22.7 gal (86.0 L)
Hydraulic system:	
Reservoir	10.6 gal (40.0 L)
Total	14.0 gal (53.0 L)
Front and rear axle:	
Front axle	2.3 gal (8.7 L)
Rear axle	2.6 gal (10.0 L)
Rear axle HS	2.5 gal (9.45 L)
Engine oil w/ filter	1.8 gal (7.0 L)
Cooling*	3.4 gal (13.0 L)

NOTE: *1.72 gal (6.5 L) antifreeze + 1.72 gal (6.5 L) water.

OTHER SPECIFICATIONS

Lift cylinders	Two (2)
Bore diameter	3.25 in (82.5 mm)
Rod diameter	1.97 in (50.0 mm)
Stroke	29.57 in (751.0 mm)

Tilt cylinder:	
Bore diameter	3.49 in (88.7 mm)
Rod diameter	2.25 in (57.1 mm)
Stroke	19.96 in (507.0 mm)

Loader:
 Z-Bar loader linkage
 Single control for lift and tilt
 Positive hold float
 Hydraulic attachment coupler:
 Skid steer compatible/horizontal
 pin compatible

Cycle time:	
Z-Bar:	
Raise w/ rated bucket load	5.8 sec
Dump w/ rated bucket load	1.7 sec
Lower – empty	3.8 sec

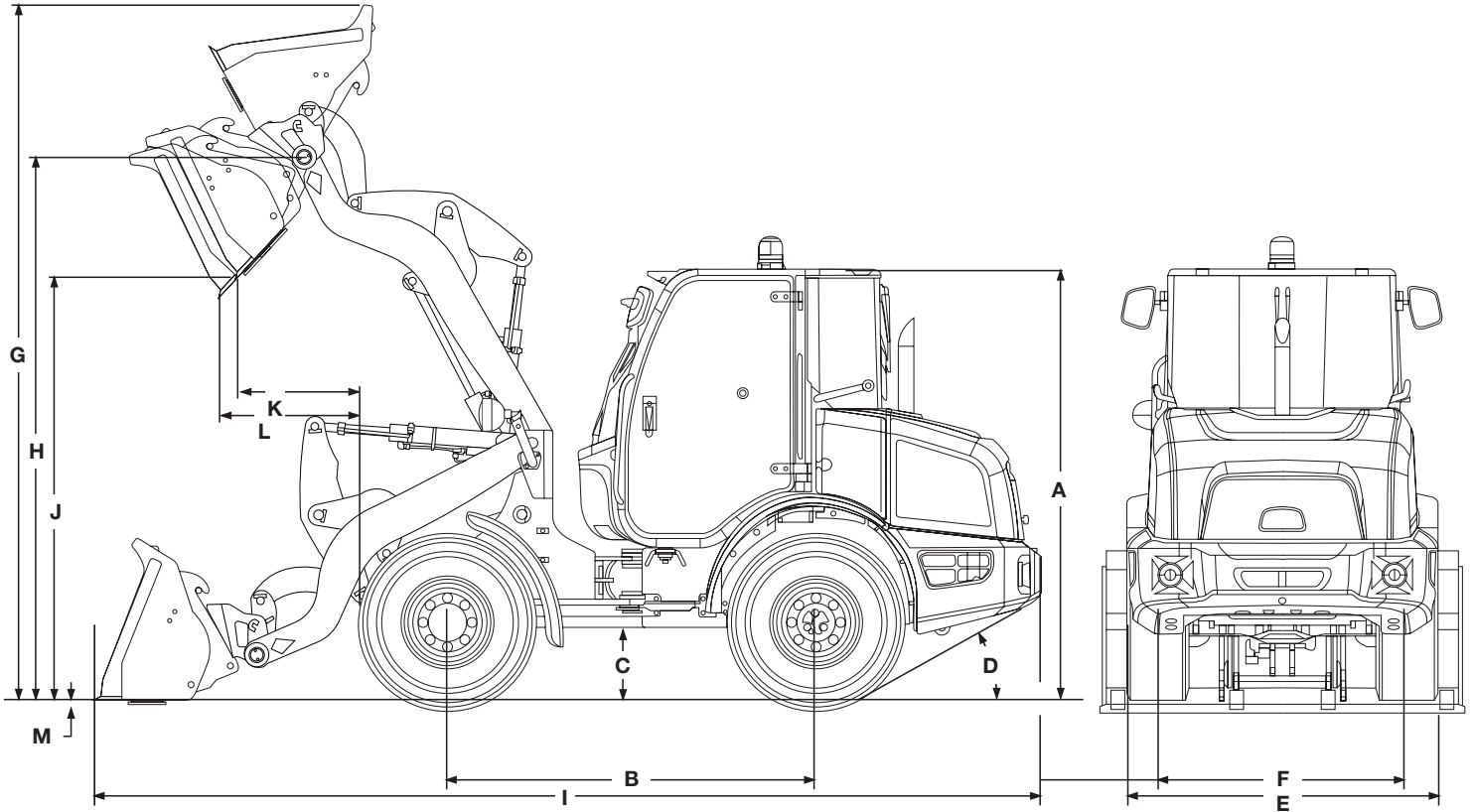

Line drawings are for illustrative purpose only and may not be exact representation of unit.

DIMENSIONS

A. Height to top of ROPS cab	103.4 in (2 627 mm)
B. Wheelbase	87.6 in (2 225 mm)
C. Ground clearance under shaft	17.3 in (440 mm)
Ground clearance under axles	12.5 in (317 mm)
D. Angle of departure	27°
Width:	
E. Overall without bucket	73.2 in (1 860 mm)
F. Centerline tread	59.1 in (1 500 mm)
Turning radius – outside	157.0 in (3 987 mm)
Turning angle:	
From center	40°
Total angle	80°
Rear axle oscillation – total	20°

PERFORMANCE SPECS

221F Z-Bar	1.2 yd³ GP (0.9 m³) GP Bucket with Bolt-on Edge	1.56 yd³ GP (1.2 m³) LM Bucket with Bolt-on Edge
ISO bucket capacity – struck	0.92 yd ³ (0.7 m ³)	1.31 yd ³ (1.0 m ³)
Heaped	1.18 yd ³ (0.9 m ³)	1.57 yd ³ (1.2 m ³)
Bucket width – outside	80.7 in (2 050 mm)	82.7 in (2 100 mm)
Bucket weight – includes coupler and added components	1,060 lb (481 kg)	1,160 lb (526 kg)
G. Operating height – fully raised with spillguard	170.4 in (4 327 mm)	176.0 in (4 470 mm)
H. Hinge pin height – fully raised	129.5 in (3 290 mm)	129.5 in (3 289 mm)
I. Overall length – bucket level on ground	231.1 in (5 869 mm)	234.8 in (5 964 mm)
Dump angle – fully raised	48°	48°
J. Dump height – fully raised, 45° dump	95.5 in (2 425 mm)	92.8 in (2 358 mm)
K. Bucket reach – fully raised, 45° dump	40.2 in (1 020 mm)	42.8 in (1 087 mm)
L. Bucket reach – 7 ft 0 in (2.13 m) height, 45° dump	51.5 in (1 309 mm)	51.9 in (1 318 mm)
M. Dig depth	3.9 in (98 mm)	3.9 in (98 mm)
Operating Load (ROC) - ISO	4,007 lb (1 818 kg)	3,984 lb (1 807 kg)
Maximum material density – ISO	3,404 lb/yd ³ (2 020 kg/m ³)	2,538 lb/yd ³ (1 506 kg/m ³)
Tipping load – ISO:		
Straight	9,318 lb (4 227 kg)	9,287 lb (4 212 kg)
40° turn	8,014 lb (3 635 kg)	7,968 lb (3 614 kg)
Lift capacity:		
Full height	8,317 lb (3 773 kg)	8,217 lb (3 727 kg)
Maximum reach	10,597 lb (4 807 kg)	10,497 lb (4 761 kg)
Ground	12,975 lb (5 886 kg)	12,796 lb (5 804 kg)
Breakout force with tilt cylinder	10,959 lb (4 971 kg)	9,109 lb (4 132 kg)
Maximum rollback:		
@ Ground	40°	40°
@ Carry position	46°	46°
@ Maximum reach	62°	62°
@ Full height	62°	62°
Maximum grading angle with bucket – back dragging	58°	60°
Loader clearance circle with bucket	368.9 in (9 371 mm)	373.4 in (9 484 mm)

FORKS

221F Z-Bar	
Fork length	47.2 in (1 200 mm)
Fork weight – includes coupler	880 lb (399 kg)
Operating load – level ground	5,002 lb (2 269 kg)
Operating mass	12,364 lb (5 608 kg)
Tipping load – straight	6,898 lb (3 129 kg)
Tipping load – 40° turn	6,252 lb (2 836 kg)
Fork load center	19.7 in (500 mm)

STANDARD EQUIPMENT

OPERATOR ENVIRONMENT

See page 1

ENGINE

FPT F5H FL463 A
Fuel filter with water trap
Dual element air cleaner

LOADER

See page 2

DRIVETRAIN

4-wheel drive
Open – front and rear axles
Hydrostatic transmission
Single joystick with electronic speed shift control F/N/R switch and proportional loader control
Outboard planetary axles
Hydraulic wet disc brakes
Mechanical parking brake

HYDRAULICS

3-spool loader control valve
3 Diagnostic quick couplers
Adjustable electro hydraulic (EH) loader controls
Smooth, moderate & aggressive settings for both lift and tilt responsiveness:
Return to Dig
Hydraulic skid steer compatible coupler
Connect under pressure connectors
Remote drain of hydraulic oil
Aux. Hydraulic drain line coupling
Auxiliary flow 22.5 gpm @ 3,336 psi
(85 l/min @ 230 bar)

OTHER

Front and rear fenders
Lights:
2 Front driving headlights – high/low beam
2 Rear flood lights
2 Stop tail lights and backup light
Front and rear turn signal/flash
Drawbar pin
Articulation locking pin
Tie-down and Lift-up point – front and rear
Backup alarm
Tool box
Rotating beacon
Wired for radio
Bucket position indicator
Front electrical socket for powered attachments

OPTIONAL EQUIPMENT

OPERATOR ENVIRONMENT

Creep speed 0 – 3.1 mph (5 kph)
TeleScop adjustable steering column on Deluxe Cab
Canopy cab
Limited slip – front and rear axles
100% lock – front and open rear axles
Horizontal pin coupler
Radio, antenna, and speakers

LOADER

Optional High flow:
Max. 34.3 gpm @ 2500 RPM @ 2,901 psi
(Max. 130 L/min @ 2500 RPM @ 20 000 kPa)
Buckets – see performance data:
General purpose standard
General purpose light material
STD forks
Auto Ride Control
Cold weather with Block Heater - Two 680 CCA batteries and Low-temp Hytran oil

TIRES

14.5-20MPT-04 MITAS
365/80 R20 SPT9 L2(DL.)
365/70 R18 SPT9 L2 DUNL. – Standard
12.5-20 10PRMPT04TBL MITAS
365/80 R20 EM MITAS
365/70 R18 EM MITAS
550/45 R22.5 Flotation Tire
360/80 Nokian Tri 2 Snow

OTHER

CASE SiteWatch Telematics
LED work lights, 2 front and 2 Rear

CaseCE.com

©2023 CNH Industrial America LLC. All rights reserved. CASE is a trademark registered in the United States and many other countries, owned by or licensed to CNH Industrial N.V., its subsidiaries or affiliates. CNH Industrial Capital is a trademark in the United States and many other countries, owned by or licensed to CNH Industrial N.V., its subsidiaries or affiliates. Printed in U.S.A. Contains 10% post-consumer fiber.

IMPORTANT: CASE Construction Equipment Inc. reserves the right to change these specifications without notice and without incurring any obligation relating to such change. Availability of some models and equipment builds vary according to the country in which the equipment is used. The illustrations and text may include optional equipment and accessories and may not include all standard equipment. Your CASE dealer/distributor will be able to give you details of the products and their specifications available in your area.



CASE Construction Equipment is biodiesel-friendly. NOTE: All engines meet current EPA emissions regulations. All specifications are stated in accordance with SAE Standards or Recommended Practices, where applicable.



Always read the Operator's Manual before operating any equipment. Inspect equipment before using it, and be sure it is operating properly. Follow the product safety signs and use any safety features provided.

Form No. CCE202302221F
Replaces Form No. CCE202212221F