



ENGINE

| | |
|--|--|
| Make | FPT |
| Model | F4HFE613T |
| Emissions Certification | Tier 4 Final |
| Emissions Technology | SCR/DOC |
| Type | 4-stroke, turbocharged and air-to-air cooled |
| Cylinders | 6-cylinder in-line |
| Bore/Stroke | 4.09 x 5.20 in (104 x 132 mm) |
| Displacement | 411 in ³ (6.7 L) |
| Fuel | #2 Diesel, #1 and #2 mixture permitted for cold temperatures |
| Fuel injection | Direct injection – electronic |
| Fuel filter | Replaceable |
| Fuel pump | Bosch CR/CP3 |
| Gradeability: | |
| Side-to-side | 35° |
| Fore and aft | 35° |
| Air filter | Dry type elements w/ warning restriction indicator |
| Mid-mount cooling module: | Mid-mount air/water |
| Fan – hydraulic driven: | |
| Style | 8 blade puller |
| Diameter | 32 in (813 mm) |
| Water pump | Integral |
| Engine oil pump operating angle ratings: | |
| Side-to-side | 35° |
| Fore and aft | 35° |
| Oil filtration | Replaceable |
| Engine speeds | RPM |
| Rated – full load | 2000 |
| Horsepower: | |
| Maximum Power Mode: | |
| Peak gross @ 2000 RPM | 195 hp (145 kW) |
| Net rated @ 2000 RPM | 179 hp (133 kW) |
| Peak net @ 2000 RPM | 179 hp (133 kW) |
| Standard Power Mode: | |
| Peak gross @ 1700 RPM | 176 hp (131 kW) |
| Net rated @ 2000 RPM | 144 hp (107 kW) |
| Peak net @ 1600 RPM | 163 hp (121 kW) |
| Economy Power Mode: | |
| Peak gross @ 1400 RPM | 147 hp (109 kW) |
| Net rated @ 2000 RPM | 121 hp (90 kW) |
| Peak net @ 1400 RPM | 138 hp (103 kW) |

| | |
|----------------------|---------------------|
| Torque – peak: | |
| Maximum Power Mode: | |
| Gross @ 1300 RPM | 701 lb-ft (950 N-m) |
| Net @ 1300 RPM | 674 lb-ft (914 N-m) |
| Standard Power Mode: | |
| Gross @ 1300 RPM | 620 lb-ft (841 N-m) |
| Net @ 1300 RPM | 594 lb-ft (805 N-m) |
| Economy Power Mode: | |
| Gross @ 1200 RPM | 589 lb-ft (799 N-m) |
| Net @ 1200 RPM | 567 lb-ft (768 N-m) |

| | |
|--|-----|
| Torque rise: | |
| Maximum power range | 37% |
| NOTE: Gross horsepower and torque per SAE J1995. Net horsepower and torque per SAE J1349. | |

DRIVETRAIN

| | |
|--|-----------------|
| Transmission: | |
| 4F/3R Proportional w/ Electronic Control Module torque sensing autoshift/manual shift and modulation | |
| Gears | Helical cut |
| Gear ratios – 4-speed | |
| | Forward/Reverse |
| 1st | 3.745/3.551 |
| 2nd | 2.184/2.071 |
| 3rd | 1.072/1.017 |
| 4th | 0.636/ – |
| Gear ratios – 5-speed | |
| | Forward/Reverse |
| 1st | 3.921/3.718 |
| 2nd | 2.255/2.138 |
| 3rd | 1.466/0.894 |
| 4th | 0.942/ – |
| 5th | 0.613/ – |
| Torque converter: | |
| Stall ratio – 4-speed | 2.81:1 |
| Stall ratio – 5-speed | 2.42:1 |
| Differential: | |
| Limited slip w/ 30% transfer on front and rear axles | |
| Rear axle oscillation | 24° total |
| Front and rear axles: | |
| Differential ratio | 3.4/3.2 |
| Planetary ratio | 6.0/6.4 |
| Final axle ratio | 20.2/20.4 |
| Heavy-duty axles – optional: | |
| Front axle equipped w/ locking differential | |
| Rear axle equipped w/ open differential | |
| Planetaries | Outboard |

| | |
|--|---|
| Service brakes: | |
| Hydraulically actuated, maintenance-free, multiple wet disc w/ accumulator to all four wheels | |
| Brake surface area: | |
| Front hub – each | 600 in ² (0.387 m ²) |
| Rear hub – each | 600 in ² (0.387 m ²) |
| Parking brakes: | |
| Spring-applied hydraulic release disc on transmission output shaft neutralizes power flow to wheels when engaged | |

| | | |
|---------------------------------------|-------------|-------------|
| Travel speeds – 4-speed transmission: | | |
| | Forward | Reverse |
| | mph (kph) | mph (kph) |
| 1st | 4.7 (7.6) | 5.0 (8.0) |
| 2nd | 7.9 (12.8) | 8.4 (13.4) |
| 3rd | 15.2 (24.5) | 15.9 (25.7) |
| 4th | 23.5 (37.8) | – |

| | | |
|---------------------------------------|-------------|-------------|
| Travel speeds – 5-speed transmission: | | |
| | Forward | Reverse |
| | mph (kph) | mph (kph) |
| 1st | 4.5 (7.2) | 4.9 (7.9) |
| 2nd | 7.8 (12.6) | 8.4 (13.5) |
| 3rd | 11.8 (19.0) | 19.3 (31.1) |
| 4th | 18.3 (29.5) | – |
| 5th | 25.0 (40.0) | – |

NOTE: Travel speeds at full engine throttle w/ 20.5 x 25 L3 tires.

ELECTRICAL

| | |
|---------------|---------------------------|
| Voltage | 24 Volts, negative ground |
| Alternator | 120 amp |
| Batteries (2) | 12-volt |

OPERATOR ENVIRONMENT

ROPS cab AC w/ heat; Key start; Articulated power steering w/ tilt column; Fully adjustable, suspension seat; Foot throttle; Single lever loader control w/ fully adjustable wrist rest, 2 cup holders; 2 interior rear view mirrors; 2 in (51 mm) retractable seat belt; Multiple storage trays; Single brake pedal; F/N/R shuttle switch; External rearview mirrors; Pressurized air filtering; Anti-glare window strip; Front and Rear Defroster; Side window, partial/fully open; 2 Dome lights; Wipers, rear and intermittent front; Windshield washers, front and rear; Rubber floor mat; Horn.

Displays/Gauges:

| | |
|-------------|--|
| Digital: | Transmission oil temperature; Hydraulic oil temperature; Fuel Level; Engine coolant temperature; DEF level. |
| LCD screen: | Hour meter; Engine speed; Travel speed; Time; Automatic transmission indication; Current gear selection; FNR indication; DeClutch indication; Engine mode indication; Trip computer A/B; Fuel consumption; Multiple languages, Metric/English; Engine diagnostics; Transmission diagnostics; Warning prompts; Error reporting; Diff. lock*; DEF gauge. |

Audible/Visual alarms:

Warning lights:
Four-way flashers and turn signals; Brake pressure; Lamp/high beam indication; Grid heater*.

Caution warnings:

Parking brake; Coolant temperature; Hydraulic oil temperature; Transmission oil temperature; Air filter; Transmission filter; Hydraulic filter; Alternator; Low fuel.

Critical warnings:

Engine oil pressure; Brake pressure; Steering pressure – w/ aux. steering*; Coolant temperature; Hydraulic oil temperature; Transmission oil temperature.

Backup alarm**Maintenance reminders:**

Cab air filter; Engine oil filter; Fuel pre-filter; DEF tank vent filter; SCR supply filter; Hydraulic oil and filter; Engine air filter; Engine coolant drive belt; Cab recirculation filter; Engine breather filter; Transmission breather; Front and rear axle fluid; SCR supply module filter.

NOTE: *If equipped w/ option.

OPERATING WEIGHT**Z-Bar**

Unit equipped w/ 3.25 yd³ (2.5 m³) MD pin on w/ bolt on edge; 20.5-R25 L3 Radial tires; ROPS cab w/ heater and A/C; Std. battery; Heavy counterweight – 2,764 lb (1 254 kg); Front and rear fenders; Lights; Full fuel/urea; 165 lb (75 kg) operator:

32,492 lb (14 738 kg)

XT

Unit equipped w/ 3.0 yd³ (2.3 m³) CNH GP w/ BOE and CNH JRB coupler w/ edge; 20.5-R25 L3 Radial tires; ROPS cab w/ heater and A/C; Std. battery; Heavy counterweight – 2,764 lb (1 254 kg); Front and rear fenders; Lights; Full fuel/urea; 165 lb (75 kg) operator:

33,392 lb (15 146 kg)

XR

Unit equipped w/ 3.0 yd³ (2.3 m³) pin on bucket w/ bolt on edge; 20.5-R25 L3 Radial tires; ROPS cab w/ heater and A/C; Std. battery; Heavy counterweight – 2,764 lb (1 254 kg); Front and rear fenders; Lights; Full fuel/urea; 165 lb (75 kg) operator:

32,851 lb (14 901 kg)

HYDRAULICS**Main pump – steering/implement:**

Closed center pressure/flow compensated

Tandem variable displacement – load-sensing:

Max. rated flow P1: 31.6 gpm @ 2000 RPM
(120 L/min @ 2000 RPM)

Max. rated flow P2: 22.6 gpm @ 2000 RPM
(86 L/min @ 2000 RPM)

Loader control valve:

Closed-center, sectional 2, 3 or 4-function w/ control for lift, tilt and auxiliary hydraulics

Loader auxiliary steering:

Hydraulic orbital center-pivot articulating w/ on-demand oil flow

High pressure standby:

Implement 3,625 psi (25 000 kPa)
Steering 3,500 psi (24 132 kPa)

Filtration:

Filtered vent w/ relief on hydraulic reservoir, maintains 3-5 psi on reservoir, 10-micron, return filter furnishes only clean oil to all components of the system

SERVICE CAPACITIES

Fuel tank 65.0 gal (246.0 L)

DEF tank – Diesel Exhaust Fluid:

Usable capacity 9.8 gal (37.1 L)
Total 15.6 gal (58.9 L)

Hydraulic system:

Reservoir 24.0 gal (90.8 L)
Total 47.0 gal (177.8 L)

Transmission:

Service w/ filter 9.0 gal (34.0 L)

Front and rear axle:

Front axle 37.0 qt (35.0 L)
Rear axle 24.3 qt (23.0 L)

Front and rear axle – optional:

Front axle 37.0 qt (35.0 L)
Rear axle 37.0 qt (35.0 L)

Engine oil w/ filter 16.0 qt (15.1 L)

Cooling system 30.0 qt (28.4 L)

OTHER SPECIFICATIONS**Lift cylinder:**

Bore diameter 4.8 in (121 mm)
Rod diameter 3.0 in (76 mm)
Stroke 32.6 in (828 mm)

Dump cylinder – Z-Bar and XR:

Bore diameter 5.8 in (146 mm)
Rod diameter 3.0 in (76 mm)
Stroke 24.8 in (629 mm)

Dump cylinder – XT:

Bore diameter 4.5 in (114 mm)
Rod diameter 2.3 in (57 mm)
Stroke 33.7 in (857 mm)

Loader:

Z-Bar loader linkage; Single control for lift and tilt; Positive hold float; Automatic return-to-dig; Automatic height control; Automatic return-to-travel; Brake pedal transmission disconnect; Bucket position indicator on bucket.

Cycle time:

Raise w/ rated bucket load:
Z-Bar 5.2 sec
XR 5.2 sec
XT 5.2 sec

Dump w/ rated bucket load:

Z-Bar 1.2 sec
XR 1.2 sec
XT 1.3 sec

Float down:

Z-Bar 2.4 sec
XR 2.4 sec
XT 2.4 sec

Sound level in Cab (LpA) 68 dB(A)

Exterior sound level (LwA) 103 dB(A)

NOTE: Sound level data tested in accordance with ISO6395, 6396, 3744.

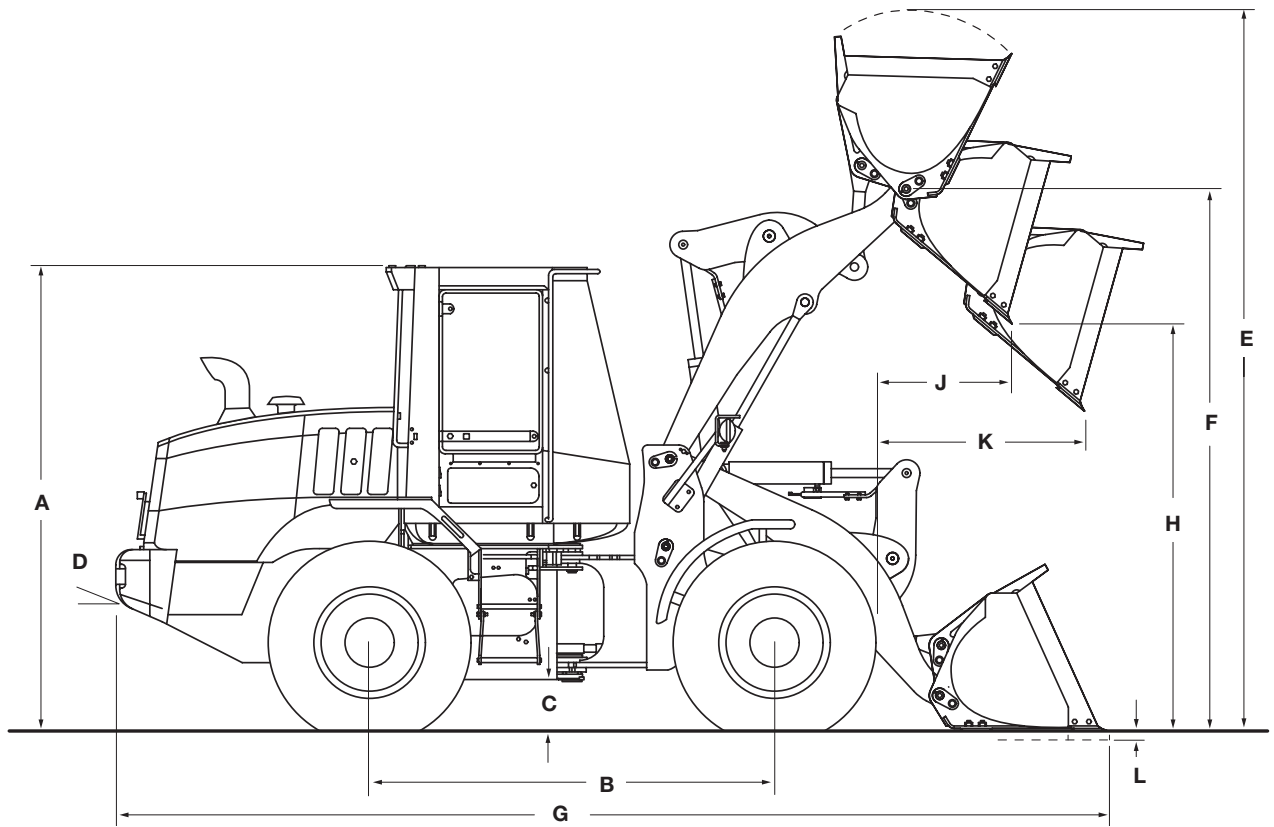

Line drawings are for illustrative purpose only and may not be exact representation of unit.

DIMENSIONS

| | |
|-------------------------------------|---------------------|
| A. Height to top of ROPS cab | 133.0 in (3 378 mm) |
| Height to drawbar | 43.5 in (1 105 mm) |
| B. Wheelbase | 128.1 in (3 253 mm) |
| C. Ground clearance | 15.1 in (384 mm) |
| D. Angle of departure | 29° |
| Width: | |
| Overall* without bucket | 100.7 in (2 558 mm) |
| Centerline tread | 79.9 in (2 030 mm) |
| Turning radius* – outside | 226.3 in (5 748 mm) |
| Turning angle: | |
| From center | 40° |
| Total angle | 80° |
| Rear axle oscillation – total | 24° |

NOTE: *Dimensions taken with 20.5-R25 L3 Radial tires. Additional dimensions on pages 4 through 8.

WEIGHT ADJUSTMENTS

| Select Options | Weight Adjustment | Tipping Load Adjustment Straight: Deflected* | Tipping Load Adjustment 40° Turn: Deflected* |
|--|-----------------------|---|---|
| 20.5 x 25 16 ply L2 Bias tires | -564 lb (-256 kg) | -565 lb (-256 kg) | -810 lb (-367 kg) |
| 20.5 x 25 16 ply L3 Bias tires | -536 lb (-243 kg) | +99 lb (+45 kg) | +184 lb (+83 kg) |
| 20.5-R25 L2 Radial tires | -256 lb (-116 kg) | -262 lb (-119 kg) | -163 lb (-74 kg) |
| 20.5-R25 Snow Radial Tires | -132 lb (-60 kg) | -169 lb (-77 kg) | -80 lb (-36 kg) |
| 20.5-R25 Solid Tires Req. Min Cwt, Lock Diff Axles, Ltd Spd Controller | +5,545 lb (+2 515 kg) | +5,028 lb (+2 281 kg) | +4,744 lb (+2 152 kg) |
| Light Counterweight | -545 lb (-247 kg) | -1,129 lb (-512 kg) | -878 lb (-398 kg) |

NOTE: Unit equipped with Z-Bar loader arms, 3.25 yd³ (2.5 m³) pin on bucket with bolt-on edge, 20.5-R25 L3 Radial tires, ROPS cab with heater and air conditioner, heavy counterweight, heavy-duty batteries, front and rear fenders, full fuel and 165 lb (75 kg) operator. Adjust select options from rated weight.

*Tipping loads: ISO 14397-1 Deflected Tires.

PERFORMANCE SPECS

| 721G Z-Bar* | | 3.0 yd³ (2.3 m³) Bucket with Bolt-on Edge - Pin On | 2.8 yd³ (2.1 m³) Bucket with Teeth - Pin On | 3.25 yd³ (2.5 m³) Bucket with Bolt-on Edge - Pin On |
|--|-------------|---|--|--|
| Operating weight | | 32,403 lb (14 698 kg) | 32,301 lb (14 652 kg) | 32,492 lb (14 738 kg) |
| E. Operating height – fully raised with spillguard | | 203.4 in (5 165 mm) | 203.4 in (5 165 mm) | 205.7 in (5 225 mm) |
| F. Hinge pin height – fully raised | | 156.5 in (3 976 mm) | 156.5 in (3 976 mm) | 156.5 in (3 976 mm) |
| G. Overall length – bucket level on ground | | 299.4 in (7 606 mm) | 305.2 in (7 753 mm) | 301.6 in (7 660 mm) |
| Dump angle – fully raised | | 50° | 50° | 50° |
| H. Dump height – fully raised, 45° dump | | 116.6 in (2 962 mm) | 112.9 in (2 868 mm) | 115.2 in (2 926 mm) |
| J. Bucket reach – fully raised, 45° dump | | 42.6 in (1 081 mm) | 47.1 in (1 196 mm) | 44.2 in (1 123 mm) |
| K. Bucket reach – 7 ft 0 in (2.13 m) height, 45° dump | | 64.1 in (1 628 mm) | 66.9 in (1 700 mm) | 65.1 in (1 654 mm) |
| L. Dig depth | | 3.0 in (77 mm) | 3.0 in (75 mm) | 3.0 in (77 mm) |
| Operating load – ISO Rigid Tires | | 11,897 lb (5 397 kg) | 12,150 lb (5 511 kg) | 11,825 lb (5 364 kg) |
| Operating load – ISO Deflected Tires | | 10,373 lb (4 705 kg) | 10,592 lb (4 804 kg) | 10,294 lb (4 669 kg) |
| Maximum material density – ISO Rigid Tires | | 3,966 lb/yd ³ (2 353 kg/m ³) | 4,339 lb/yd ³ (2 575 kg/m ³) | 3,639 lb/yd ³ (2 159 kg/m ³) |
| Maximum material density – ISO Deflected Tires | | 3,458 lb/yd ³ (2 052 kg/m ³) | 3,783 lb/yd ³ (2 245 kg/m ³) | 3,167 lb/yd ³ (1 879 kg/m ³) |
| Tipping load – ISO Rigid Tires: | | | | |
| | Straight | 27,355 lb (12 408 kg) | 27,916 lb (12 663 kg) | 27,204 lb (12 340 kg) |
| | 40° turn | 23,795 lb (10 793 kg) | 24,300 lb (11 022 kg) | 23,651 lb (10 728 kg) |
| Tipping load – ISO Deflected Tires: | | | | |
| | Straight | 25,490 lb (11 562 kg) | 26,006 lb (11 796 kg) | 25,330 lb (11 489 kg) |
| | 40° turn | 20,745 lb (9 410 kg) | 21,184 lb (9 609 kg) | 20,587 lb (9 338 kg) |
| Lift capacity: | | | | |
| | Full height | 16,135 lb (7 319 kg) | 16,247 lb (7 369 kg) | 16,046 lb (7 278 kg) |
| | Ground | 30,124 lb (13 664 kg) | 30,568 lb (13 865 kg) | 29,913 lb (13 568 kg) |
| Breakout force with tilt cylinder | | 33,810 lb (15 336 kg) | 36,573 lb (16 589 kg) | 32,158 lb (14 587 kg) |
| Loader clearance circle with bucket | | 496.3 in (12 606 mm) | 500.0 in (12 701 mm) | 497.5 in (12 636 mm) |

| 721G XR | | 3.0 yd³ (2.3 m³) Bucket with Bolt-on Edge - Pin On | 2.8 yd³ (2.1 m³) Bucket with Teeth - Pin On | 3.25 yd³ (2.5 m³) Bucket with Bolt-on Edge - Pin On |
|--|-------------|---|--|--|
| Operating weight | | 32,851 lb (14 901 kg) | 32,748 lb (14 854 kg) | 32,939 lb (14 941 kg) |
| E. Operating height – fully raised with spillguard | | 218.9 in (5 560 mm) | 218.9 in (5 560 mm) | 221.2 in (5 620 mm) |
| F. Hinge pin height – fully raised | | 172.1 in (4 371 mm) | 172.1 in (4 371 mm) | 172.1 in (4 370 mm) |
| G. Overall length – bucket level on ground | | 313.5 in (7 963 mm) | 319.3 in (8 111 mm) | 315.7 in (8 018 mm) |
| Dump angle – fully raised | | 50° | 50° | 50° |
| H. Dump height – fully raised, 45° dump | | 132.1 in (3 356 mm) | 128.4 in (3 262 mm) | 130.8 in (3 321 mm) |
| J. Bucket reach – fully raised, 45° dump | | 42.6 in (1 082 mm) | 47.1 in (1 197 mm) | 44.2 in (1 124 mm) |
| K. Bucket reach – 7 ft 0 in (2.13 m) height, 45° dump | | 76.2 in (1 937 mm) | 79.3 in (2 014 mm) | 77.3 in (1 965 mm) |
| L. Dig depth | | 3.1 in (79 mm) | 3.0 in (77 mm) | 3.1 in (79 mm) |
| Operating load – ISO Rigid Tires | | 9,983 lb (4 528 kg) | 10,187 lb (4 621 kg) | 9,915 lb (4 497 kg) |
| Operating load – ISO Deflected Tires | | 8,805 lb (3 994 kg) | 8,987 lb (4 076 kg) | 8,732 lb (3 961 kg) |
| Maximum material density – ISO Rigid Tires | | 3,328 lb/yd ³ (1 975 kg/m ³) | 3,638 lb/yd ³ (2 159 kg/m ³) | 3,051 lb/yd ³ (1 810 kg/m ³) |
| Maximum material density – ISO Deflected Tires | | 2,935 lb/yd ³ (1 742 kg/m ³) | 3,210 lb/yd ³ (1 904 kg/m ³) | 2,687 lb/yd ³ (1 594 kg/m ³) |
| Tipping load – ISO Rigid Tires: | | | | |
| | Straight | 23,078 lb (10 468 kg) | 23,527 lb (10 672 kg) | 22,935 lb (10 403 kg) |
| | 40° turn | 19,967 lb (9 057 kg) | 20,373 lb (9 241 kg) | 19,830 lb (8 995 kg) |
| Tipping load – ISO Deflected Tires: | | | | |
| | Straight | 21,678 lb (9 833 kg) | 22,099 lb (10 024 kg) | 21,528 lb (9 765 kg) |
| | 40° turn | 17,610 lb (7 988 kg) | 17,974 lb (8 153 kg) | 17,463 lb (7 921 kg) |
| Lift capacity: | | | | |
| | Full height | 15,025 lb (6 815 kg) | 15,135 lb (6 865 kg) | 14,936 lb (6 775 kg) |
| | Ground | 25,085 lb (11 378 kg) | 25,444 lb (11 541 kg) | 24,897 lb (11 293 kg) |
| Breakout force with tilt cylinder | | 33,706 lb (15 289 kg) | 36,459 lb (16 537 kg) | 32,058 lb (14 541 kg) |
| Loader clearance circle with bucket | | 509.7 in (12 945 mm) | 513.9 in (13 052 mm) | 511.0 in (12 980 mm) |

| 721G | | Z-Bar/XR | Z-Bar/XR | Z-Bar/XR |
|---|----------------|---|---|---|
| Maximum rollback: | | | | |
| | Ground | 40°/37° | 40°/37° | 40°/37° |
| | Carry position | 44°/43° | 44°/43° | 44°/43° |
| | @ Full height | 57°/57° | 57°/57° | 57°/57° |
| Maximum grading angle with bucket – back dragging | | 58°/58° | 59°/58° | 58°/58° |
| SAE bucket capacity – struck | | 2.56 yd ³ (1.96 m ³) | 2.42 yd ³ (1.85 m ³) | 2.78 yd ³ (2.13 m ³) |
| Heaped | | 3.00 yd ³ (2.29 m ³) | 2.80 yd ³ (2.14 m ³) | 3.25 yd ³ (2.48 m ³) |
| Bucket width – outside | | 106.3 in (2 700 mm) | 106.8 in (2 713 mm) | 106.3 in (2 700 mm) |
| Bucket weight | | 2,540 lb (1 152 kg) | 2,438 lb (1 106 kg) | 2,629 lb (1 192 kg) |

PERFORMANCE SPECS

| 721G Z-Bar* | | 3.0 yd³ (2.3 m³) Bucket with Teeth - Pin On | 3.5 yd³ (2.7 m³) Bucket with Bolt-on Edge - Pin On | 3.5 yd³ (2.7 m³) Bucket with Bolt-on Edge & Grapple - Pin On |
|--|-------------|--|---|---|
| Operating weight | | 32,390 lb (14 692 kg) | 32,633 lb (14 802 kg) | 34,425 lb (15 615 kg) |
| E. Operating height – fully raised with spillguard | | 205.7 in (5 225 mm) | 208.4 in (5 294 mm) | 273.2 in (6 941 mm) |
| F. Hinge pin height – fully raised | | 156.5 in (3 976 mm) | 156.5 in (3 976 mm) | 156.4 in (3 973 mm) |
| G. Overall length – bucket level on ground | | 307.3 in (7 805 mm) | 304.0 in (7 721 mm) | 304.0 in (7 721 mm) |
| Dump angle – fully raised | | 50° | 50° | 50° |
| H. Dump height – fully raised, 45° dump | | 111.6 in (2 834 mm) | 113.7 in (2 888 mm) | 113.6 in (2 886 mm) |
| J. Bucket reach – fully raised, 45° dump | | 48.6 in (1 236 mm) | 46.0 in (1 169 mm) | 46.0 in (1 167 mm) |
| K. Bucket reach – 7 ft 0 in (2.13 m) height, 45° dump | | 67.8 in (1 723 mm) | 66.2 in (1 682 mm) | 66.1 in (1 680 mm) |
| L. Dig depth | | 3.0 in (75 mm) | 3.0 in (77 mm) | 3.1 in (80 mm) |
| Operating load – ISO Rigid Tires | | 12,005 lb (5 445 kg) | 11,711 lb (5 312 kg) | 10,837 lb (4 915 kg) |
| Operating load – ISO Deflected Tires | | 10,450 lb (4 740 kg) | 10,174 lb (4 615 kg) | 9,269 lb (4 204 kg) |
| Maximum material density – ISO Rigid Tires | | 4,002 lb/yd ³ (2 374 kg/m ³) | 3,346 lb/yd ³ (1 985 kg/m ³) | 3,096 lb/yd ³ (1 837 kg/m ³) |
| Maximum material density – ISO Deflected Tires | | 3,483 lb/yd ³ (2 067 kg/m ³) | 2,907 lb/yd ³ (1 725 kg/m ³) | 2,648 lb/yd ³ (1 571 kg/m ³) |
| Tipping load - ISO Rigid Tires: | Straight | 27,597 lb (12 518 kg) | 26,963 lb (12 230 kg) | 25,214 lb (11 437 kg) |
| | 40° turn | 24,010 lb (10 891 kg) | 23,423 lb (10 624 kg) | 21,674 lb (9 831 kg) |
| Tipping load - ISO Deflected Tires: | Straight | 25,691 lb (11 653 kg) | 25,081 lb (11 377 kg) | 23,297 lb (10 567 kg) |
| | 40° turn | 20,901 lb (9 480 kg) | 20,348 lb (9 230 kg) | 18,537 lb (8 408 kg) |
| Lift capacity: | Full height | 16,155 lb (7 328 kg) | 15,904 lb (7 214 kg) | 14,116 lb (6 403 kg) |
| | Ground | 30,217 lb (13 706 kg) | 29,622 lb (13 436 kg) | 27,759 lb (12 591 kg) |
| Breakout force with tilt cylinder | | 34,749 lb (15 762 kg) | 30,485 lb (13 828 kg) | 28,621 lb (12 982 kg) |
| Loader clearance circle with bucket | | 501.2 in (12 731 mm) | 498.8 in (12 671 mm) | 498.8 in (12 670 mm) |

| 721G XR | | 3.0 yd³ (2.3 m³) Bucket with Teeth - Pin On | 3.5 yd³ (2.7 m³) Bucket with Bolt-on Edge - Pin On | 3.5 yd³ (2.7 m³) Bucket with Bolt-on Edge & Grapple - Pin On |
|--|-------------|--|---|---|
| Operating weight | | 32,837 lb (14 895 kg) | 33,080 lb (15 005 kg) | 34,872 lb (15 818 kg) |
| E. Operating height – fully raised with spillguard | | 221.2 in (5 620 mm) | 224.0 in (5 689 mm) | 288.8 in (7 335 mm) |
| F. Hinge pin height – fully raised | | 172.1 in (4 371 mm) | 172.1 in (4 370 mm) | 172.0 in (4 368 mm) |
| G. Overall length – bucket level on ground | | 321.4 in (8 163 mm) | 318.1 in (8 078 mm) | 318.0 in (8 078 mm) |
| Dump angle – fully raised | | 50° | 50° | 50° |
| H. Dump height – fully raised, 45° dump | | 127.1 in (3 229 mm) | 129.2 in (3 282 mm) | 129.2 in (3 281 mm) |
| J. Bucket reach – fully raised, 45° dump | | 48.7 in (1 237 mm) | 46.1 in (1 170 mm) | 46.0 in (1 168 mm) |
| K. Bucket reach – 7 ft 0 in (2.13 m) height, 45° dump | | 80.3 in (2 039 mm) | 78.5 in (1 995 mm) | 78.5 in (1 993 mm) |
| L. Dig depth | | 3.1 in (78 mm) | 3.1 in (80 mm) | 3.2 in (82 mm) |
| Operating load – ISO Rigid Tires | | 10,064 lb (4 565 kg) | 9,809 lb (4 449 kg) | 8,926 lb (4 049 kg) |
| Operating load – ISO Deflected Tires | | 8,865 lb (4 021 kg) | 8,621 lb (3 911 kg) | 7,713 lb (3 499 kg) |
| Maximum material density – ISO Rigid Tires | | 3,355 lb/yd ³ (1 991 kg/m ³) | 2,803 lb/yd ³ (1 663 kg/m ³) | 2,550 lb/yd ³ (1 513 kg/m ³) |
| Maximum material density – ISO Deflected Tires | | 2,955 lb/yd ³ (1 753 kg/m ³) | 2,463 lb/yd ³ (1 462 kg/m ³) | 2,204 lb/yd ³ (1 308 kg/m ³) |
| Tipping load – ISO Rigid Tires: | Straight | 23,258 lb (10 550 kg) | 22,712 lb (10 302 kg) | 20,946 lb (9 501 kg) |
| | 40° turn | 20,127 lb (9 130 kg) | 19,619 lb (8 899 kg) | 17,853 lb (8 098 kg) |
| Tipping load – ISO Deflected Tires: | Straight | 21,831 lb (9 902 kg) | 21,299 lb (9 661 kg) | 19,506 lb (8 848 kg) |
| | 40° turn | 17,729 lb (8 042 kg) | 17,243 lb (7 821 kg) | 15,426 lb (6 997 kg) |
| Lift capacity: | Full height | 15,044 lb (6 824 kg) | 14,794 lb (6 710 kg) | 13,005 lb (5 899 kg) |
| | Ground | 25,151 lb (11 408 kg) | 24,637 lb (11 175 kg) | 22,768 lb (10 327 kg) |
| Breakout force with tilt cylinder | | 34,641 lb (15 713 kg) | 30,391 lb (13 785 kg) | 28,529 lb (12 940 kg) |
| Loader clearance circle with bucket | | 515.2 in (13 087 mm) | 512.6 in (13 020 mm) | 512.5 in (13 019 mm) |

| 721G | | Z-Bar/XR | Z-Bar/XR | Z-Bar/XR |
|---|----------------|---|---|---|
| Maximum rollback: | Ground | 40°/37° | 40°/37° | 40°/37° |
| | Carry position | 44°/43° | 44°/43° | 44°/43° |
| | @ Full height | 57°/57° | 57°/57° | 57°/57° |
| Maximum grading angle with bucket – back dragging | | 59°/59° | 59°/58° | 59°/58° |
| SAE bucket capacity – struck | | 2.62 yd ³ (2.00 m ³) | 3.00 yd ³ (2.29 m ³) | 3.00 yd ³ (2.29 m ³) |
| | Heaped | 3.00 yd ³ (2.29 m ³) | 3.50 yd ³ (2.68 m ³) | 3.50 yd ³ (2.68 m ³) |
| Bucket width – outside | | 106.8 in (2 713 mm) | 106.3 in (2 700 mm) | 106.3 in (2 700 mm) |
| Bucket weight | | 2,526 lb (1 146 kg) | 2,769 lb (1 256 kg) | 4,561 lb (2 069 kg) |

PERFORMANCE SPECS

| 721G Z-Bar* | | 5.5 yd³ (4.2 m³) Bucket with Bolt-on Edge - Pin On | 3.0 yd³ (2.3 m³) Bucket with Bolt-on Edge - ACS Coupler | 2.8 yd³ (2.14 m³) Bucket with Teeth - ACS Coupler |
|--|--|---|--|--|
| Operating weight | | 33,265 lb (15 089 kg) | 33,414 lb (15 156 kg) | 33,312 lb (15 110 kg) |
| E. Operating height – fully raised with spillguard | | 223.0 in (5 665 mm) | 208.6 in (5 298 mm) | 208.6 in (5 298 mm) |
| F. Hinge pin height – fully raised | | 156.5 in (3 975 mm) | 156.5 in (3 975 mm) | 156.5 in (3 975 mm) |
| G. Overall length – bucket level on ground | | 320.2 in (8 132 mm) | 307.2 in (7 802 mm) | 312.9 in (7 948 mm) |
| Dump angle – fully raised | | 50° | 50° | 50° |
| H. Dump height – fully raised, 45° dump | | 102.9 in (2 613 mm) | 111.6 in (2 835 mm) | 107.9 in (2 741 mm) |
| J. Bucket reach – fully raised, 45° dump | | 56.7 in (1 439 mm) | 48.4 in (1 231 mm) | 52.8 in (1 342 mm) |
| K. Bucket reach – 7 ft 0 in (2.13 m) height, 45° dump | | 71.1 in (1 806 mm) | 67.7 in (1 719 mm) | 70.2 in (1 782 mm) |
| L. Dig depth | | 4.5 in (114 mm) | 3.1 in (78 mm) | 3.1 in (78 mm) |
| Operating load – ISO Rigid Tires | | 10,822 lb (4 909 kg) | 10,798 lb (4 898 kg) | 10,962 lb (4 972 kg) |
| Operating load – ISO Deflected Tires | | 9 330 lb (4 232 kg) | 9,357 lb (4 244 kg) | 9,501 lb (4 310 kg) |
| Maximum material density – ISO Rigid Tires | | 1,968 lb/yd ³ (1 168 kg/m ³) | 3,599 lb/yd ³ (2 136 kg/m ³) | 3,915 lb/yd ³ (2 323 kg/m ³) |
| Maximum material density – ISO Deflected Tires | | 1,696 lb/yd ³ (1 007 kg/m ³) | 3,119 lb/yd ³ (1 851 kg/m ³) | 3,393 lb/yd ³ (2 013 kg/m ³) |
| Tipping load – ISO Rigid Tires: | | | | |
| Straight | | 25,027 lb (11 352 kg) | 24,973 lb (11 327 kg) | 25,332 lb (11 491 kg) |
| 40° turn | | 21,644 lb (9 817 kg) | 21,595 lb (9 796 kg) | 21,924 lb (9 945 kg) |
| Tipping load – ISO Deflected Tires: | | | | |
| Straight | | 23,208 lb (10 527 kg) | 23,222 lb (10 533 kg) | 23,554 lb (10 684 kg) |
| 40° turn | | 18,660 lb (8 464 kg) | 18,714 lb (8 488 kg) | 19,002 lb (8 619 kg) |
| Lift capacity: | | | | |
| Full height | | 15,247 lb (6 916 kg) | 15,111 lb (6 854 kg) | 15,219 lb (6 903 kg) |
| Ground | | 27,872 lb (12 643 kg) | 27,954 lb (12 680 kg) | 28,241 lb (12 810 kg) |
| Breakout force with tilt cylinder | | 22,682 lb (10 288 kg) | 28,136 lb (12 762 kg) | 30,175 lb (13 687 kg) |
| Loader clearance circle with bucket | | 508.7 in (12 921 mm) | 500.7 in (12 717 mm) | 504.6 in (12 816 mm) |

| 721G XR | | 5.5 yd³ (4.2 m³) Bucket with Bolt-on Edge - Pin On | 3.0 yd³ (2.3 m³) Bucket with Bolt-on Edge - ACS Coupler | 2.8 yd³ (2.14 m³) Bucket with Teeth - ACS Coupler |
|--|--|---|--|--|
| Operating weight | | 33,712 lb (15 292 kg) | 33,861 lb (15 359 kg) | 33,759 lb (15 313 kg) |
| E. Operating height – fully raised with spillguard | | 238.6 in (6 060 mm) | 224.1 in (5 692 mm) | 224.1 in (5 692 mm) |
| F. Hinge pin height – fully raised | | 172.0 in (4 369 mm) | 172.0 in (4 369 mm) | 172.0 in (4 369 mm) |
| G. Overall length – bucket level on ground | | 334.1 in (8 486 mm) | 321.2 in (8 159 mm) | 327.0 in (8 305 mm) |
| Dump angle – fully raised | | 50° | 50° | 50° |
| H. Dump height – fully raised, 45° dump | | 118.4 in (3 008 mm) | 127.1 in (3 230 mm) | 123.5 in (3 136 mm) |
| J. Bucket reach – fully raised, 45° dump | | 56.7 in (1 440 mm) | 48.5 in (1 232 mm) | 52.9 in (1 343 mm) |
| K. Bucket reach – 7 ft 0 in (2.13 m) height, 45° dump | | 84.1 in (2 135 mm) | 80.1 in (2 034 mm) | 82.8 in (2 103 mm) |
| L. Dig depth | | 4.6 in (116 mm) | 3.2 in (81 mm) | 3.2 in (81 mm) |
| Operating load – ISO Rigid Tires | | 9,045 lb (4 103 kg) | 9,033 lb (4 097 kg) | 9,171 lb (4 160 kg) |
| Operating load – ISO Deflected Tires | | 7,886 lb (3 577 kg) | 7,909 lb (3 587 kg) | 8,032 lb (3 643 kg) |
| Maximum material density – ISO Rigid Tires | | 1,644 lb/yd ³ (976 kg/m ³) | 3,011 lb/yd ³ (1 787 kg/m ³) | 3,275 lb/yd ³ (1 943 kg/m ³) |
| Maximum material density – ISO Deflected Tires | | 1,434 lb/yd ³ (851 kg/m ³) | 2,636 lb/yd ³ (1 564 kg/m ³) | 2,869 lb/yd ³ (1 702 kg/m ³) |
| Tipping load – ISO Rigid Tires: | | | | |
| Straight | | 21,056 lb (9 551 kg) | 21,033 lb (9 541 kg) | 21,332 lb (9 676 kg) |
| 40° turn | | 18,089 lb (8 205 kg) | 18,066 lb (8 195 kg) | 18,341 lb (8 319 kg) |
| Tipping load – ISO Deflected Tires: | | | | |
| Straight | | 19,682 lb (8 928 kg) | 19,703 lb (8 937 kg) | 19,984 lb (9 065 kg) |
| 40° turn | | 15,771 lb (7 154 kg) | 15,817 lb (7 174 kg) | 16,065 lb (7 287 kg) |
| Lift capacity: | | | | |
| Full height | | 14,139 lb (6 413 kg) | 14,003 lb (6 351 kg) | 14,110 lb (6 400 kg) |
| Ground | | 23,100 lb (10 478 kg) | 23,201 lb (10 524 kg) | 23,442 lb (10 633 kg) |
| Breakout force with tilt cylinder | | 22,638 lb (10 268 kg) | 28,045 lb (12 721 kg) | 30,078 lb (13 643 kg) |
| Loader clearance circle with bucket | | 523.8 in (13 304 mm) | 514.7 in (13 073 mm) | 519.0 in (13 183 mm) |

| 721G | | Z-Bar/XR | Z-Bar/XR | Z-Bar/XR |
|---|--|---|---|---|
| Maximum rollback: | | | | |
| Ground | | 41°/38° | 40°/37° | 40°/37° |
| Carry position | | 44°/43° | 44°/43° | 44°/43° |
| @ Full height | | 57°/57° | 57°/57° | 57°/57° |
| Maximum grading angle with bucket – back dragging | | 63°/61° | 60°/59° | 61°/60° |
| SAE bucket capacity – struck | | 4.44 yd ³ (3.39 m ³) | 2.56 yd ³ (1.96 m ³) | 2.42 yd ³ (1.85 m ³) |
| Heaped | | 5.50 yd ³ (4.21 m ³) | 3.00 yd ³ (2.29 m ³) | 2.80 yd ³ (2.14 m ³) |
| Bucket width – outside | | 106.3 in (2 700 mm) | 106.3 in (2 700 mm) | 106.8 in (2 713 mm) |
| Bucket weight | | 3,402 lb (1 543 kg) | 3,551 lb (1 611 kg) | 3,449 lb (1 564 kg) |

PERFORMANCE SPECS

| 721G Z-Bar* | 3.0 yd³ (2.3 m³) Bucket with Bolt-on-Edge - JRB Coupler | 2.8 yd³ (2.14 m³) Bucket with Teeth - JRB Coupler |
|--|--|--|
| Operating weight | 33,344 lb (15 124 kg) | 33,241 lb (15 078 kg) |
| E. Operating height – fully raised with spillguard | 210.9 in (5 356 mm) | 210.9 in (5 356 mm) |
| F. Hinge pin height – fully raised | 156.5 in (3 975 mm) | 156.5 in (3 975 mm) |
| G. Overall length – bucket level on ground | 310.0 in (7 873 mm) | 315.9 in (8 025 mm) |
| Dump angle – fully raised | 50° | 50° |
| H. Dump height – fully raised, 45° dump | 109.9 in (2 791 mm) | 106.0 in (2 692 mm) |
| J. Bucket reach – fully raised, 45° dump | 51.0 in (1 296 mm) | 55.2 in (1 403 mm) |
| K. Bucket reach – 7 ft 0 in (2.13 m) height, 45° dump | 69.4 in (1 763 mm) | 71.5 in (1 816 mm) |
| L. Dig depth | 2.7 in (69 mm) | 3.0 in (77 mm) |
| Operating load – ISO Rigid Tires | 10,579 lb (4 799 kg) | 10,739 lb (4 871 kg) |
| Operating load – ISO Deflected Tires | 9,172 lb (4 160 kg) | 9,312 lb (4 224 kg) |
| Maximum material density – ISO Rigid Tires | 3,526 lb/yd ³ (2 093 kg/m ³) | 3,836 lb/yd ³ (2 276 kg/m ³) |
| Maximum material density - ISO Deflected Tires | 3,057 lb/yd ³ (1 814 kg/m ³) | 3,326 lb/yd ³ (1 973 kg/m ³) |
| Tipping load – ISO Rigid Tires: | | |
| Straight | 24,466 lb (11 098 kg) | 24,816 lb (11 256 kg) |
| 40° turn | 21,159 lb (9 597 kg) | 21,479 lb (9 743 kg) |
| Tipping load – ISO Deflected Tires: | | |
| Straight | 22,759 lb (10 323 kg) | 23,083 lb (10 470 kg) |
| 40° turn | 18,344 lb (8 321 kg) | 18,624 lb (8 448 kg) |
| Lift capacity: | | |
| Full height | 15,171 lb (6 881 kg) | 15,278 lb (6 930 kg) |
| Ground | 26,989 lb (12 242 kg) | 27,806 lb (12 613 kg) |
| Breakout force with tilt cylinder | 26,469 lb (12 006 kg) | 28,279 lb (12 827 kg) |
| Loader clearance circle with bucket | 502.3 in (12 758 mm) | 506.4 in (12 862 mm) |

| 721G XR | 3.0 yd³ (2.3 m³) Bucket with Bolt-on-Edge - JRB Coupler | 2.8 yd³ (2.1 m³) Bucket with Teeth - JRB Coupler |
|--|--|---|
| Operating weight | 33,791 lb (15 327 kg) | 33,689 lb (15 281 kg) |
| E. Operating height – fully raised with spillguard | 226.4 in (5 751 mm) | 226.4 in (5 751 mm) |
| F. Hinge pin height – fully raised | 172.0 in (4 369 mm) | 172.0 in (4 369 mm) |
| G. Overall length – bucket level on ground | 324.1 in (8 232 mm) | 330.0 in (8 383 mm) |
| Dump angle – fully raised | 50° | 50° |
| H. Dump height – fully raised, 45° dump | 125.4 in (3 186 mm) | 121.5 in (3 087 mm) |
| J. Bucket reach – fully raised, 45° dump | 51.1 in (1 297 mm) | 55.3 in (1 404 mm) |
| K. Bucket reach – 7 ft 0 in (2.13 m) height, 45° dump | 81.9 in (2 081 mm) | 84.2 in (2 140 mm) |
| L. Dig depth | 2.8 in (72 mm) | 3.1 in (79 mm) |
| Operating load – ISO Rigid Tires | 8,872 lb (4 024 kg) | 9,007 lb (4 085 kg) |
| Operating load – ISO Deflected Tires | 7,769 lb (3 524 kg) | 7,890 lb (3 579 kg) |
| Maximum material density – ISO Rigid Tires | 2,957 lb/yd ³ (1 755 kg/m ³) | 3,217 lb/yd ³ (1 909 kg/m ³) |
| Maximum material density – ISO Deflected Tires | 2,590 lb/yd ³ (1 537 kg/m ³) | 2,818 lb/yd ³ (1 672 kg/m ³) |
| Tipping load – ISO Rigid Tires: | | |
| Straight | 20,656 lb (9 369 kg) | 20,948 lb (9 502 kg) |
| 40° turn | 17,745 lb (8 049 kg) | 18,014 lb (8 171 kg) |
| Tipping load – ISO Deflected Tires: | | |
| Straight | 19,354 lb (8 779 kg) | 19,629 lb (8 903 kg) |
| 40° turn | 15,538 lb (7 048 kg) | 15,780 lb (7 158 kg) |
| Lift capacity: | | |
| Full height | 14,063 lb (6 379 kg) | 14,170 lb (6 428 kg) |
| Ground | 22,866 lb (10 372 kg) | 23,125 lb (10 489 kg) |
| Breakout force with tilt cylinder | 26,378 lb (11 965 kg) | 28,189 lb (12 786 kg) |
| Loader clearance circle with bucket | 516.5 in (13 120 mm) | 521.1 in (13 236 mm) |

| 721G | Z-Bar/XR | Z-Bar/XR |
|---|---|---|
| Maximum rollback: | | |
| Ground | 40°/37° | 40°/37° |
| Carry position | 44°/43° | 44°/43° |
| @ Full height | 57°/57° | 57°/57° |
| Maximum grading angle with bucket – back dragging | 60°/59° | 62°/60° |
| SAE bucket capacity – struck | 2.56 yd ³ (1.96 m ³) | 2.42 yd ³ (1.85 m ³) |
| Heaped | 3.00 yd ³ (2.29 m ³) | 2.80 yd ³ (2.14 m ³) |
| Bucket width – outside | 106.3 in (2 700 mm) | 106.8 in (2 713 mm) |
| Bucket weight | 3,480 lb (1 579 kg) | 3,378 lb (1 532 kg) |

PERFORMANCE SPECS

| 721G XT | 3.0 yd³ (2.3 m³) Bucket with Bolt-on Edge - ACS Coupler | 2.8 yd³ (2.1 m³) Bucket with Teeth ACS Coupler | 3.0 yd³ (2.3 m³) Bucket with Bolt-on Edge - JRB Coupler | 2.8 yd³ (2.1 m³) Bucket with Teeth JRB Coupler |
|--|--|---|--|---|
| Operating weight | 33,861 lb (15 359 kg) | 33,759 lb (15 313 kg) | 33,392 lb (15 146 kg) | 33,290 lb (15 100 kg) |
| E. Operating height – fully raised with spillguard | 219.1 in (5 564 mm) | 219.1 in (5 564 mm) | 217.1 in (5 515 mm) | 217.1 in (5 516 mm) |
| F. Hinge pin height – fully raised | 163.6 in (4 156 mm) | 163.6 in (4 156 mm) | 163.6 in (4 157 mm) | 163.7 in (4 157 mm) |
| G. Overall length – bucket level on ground | 315.2 in (8 005 mm) | 320.9 in (8 151 mm) | 312.7 in (7 942 mm) | 318.4 in (8 086 mm) |
| Dump angle – fully raised | 55° | 55° | 55° | 55° |
| H. Dump height – fully raised, 45° dump | 113.3 in (2 878 mm) | 109.6 in (2 784 mm) | 114.9 in (2 919 mm) | 111.3 in (2 827 mm) |
| J. Bucket reach – fully raised, 45° dump | 52.1 in (1 323 mm) | 56.5 in (1 435 mm) | 50.2 in (1 275 mm) | 54.6 in (1 388 mm) |
| K. Bucket reach – 7 ft 0 in (2.13 m) height, 45° dump | 73.1 in (1 856 mm) | 75.5 in (1 918 mm) | 72.0 in (1 828 mm) | 74.6 in (1 894 mm) |
| L. Dig depth | 3.5 in (90 mm) | 3.5 in (90 mm) | 3.5 in (89 mm) | 3.4 in (87 mm) |
| Operating load – ISO Rigid Tires | 9,851 lb (4 469 kg) | 9,998 lb (4 535 kg) | 10,237 lb (4 643 kg) | 10,390 lb (4 713 kg) |
| Operating load – ISO Deflected Tires | 8,481 lb (3 847 kg) | 8,611 lb (3 906 kg) | 8,844 lb (4 011 kg) | 8,978 lb (4 072 kg) |
| Maximum material density – ISO Rigid Tires | 3,284 lb/yd ³ (1 949 kg/m ³) | 3 571 lb/yd ³ (2 119 kg/m ³) | 3,412 lb/yd ³ (2 025 kg/m ³) | 3,711 lb/yd ³ (2 202 kg/m ³) |
| Maximum material density – ISO Deflected Tires | 2,827 lb/yd ³ (1 677 kg/m ³) | 3,075 lb/yd ³ (1 825 kg/m ³) | 2,948 lb/yd ³ (1 749 kg/m ³) | 3,207 lb/yd ³ (1 903 kg/m ³) |
| Tipping load – ISO Rigid Tires: | | | | |
| Straight | 22,805 lb (10 344 kg) | 23,124 lb (10 489 kg) | 23,624 lb (10 716 kg) | 23,956 lb (10 866 kg) |
| 40° turn | 19,703 lb (8 937 kg) | 19,996 lb (9 070 kg) | 20,474 lb (9 287 kg) | 20,779 lb (9 425 kg) |
| Tipping load – ISO Deflected Tires: | | | | |
| Straight | 21,152 lb (9 595 kg) | 21,449 lb (9 729 kg) | 21,942 lb (9 953 kg) | 22,250 lb (10 092 kg) |
| 40° turn | 16,962 lb (7 694 kg) | 17,222 lb (7 812 kg) | 17,687 lb (8 023 kg) | 17,957 lb (8 145 kg) |
| Lift capacity: | | | | |
| Full height | 13,839 lb (6 277 kg) | 14,003 lb (6 352 kg) | 14,396 lb (6 530 kg) | 14,564 lb (6 606 kg) |
| Ground | 31,098 lb (14 106 kg) | 31,112 lb (14,112 kg) | 31,434 lb (14 258 kg) | 31,483 lb (14 281 kg) |
| Breakout force with tilt cylinder | 26,353 lb (11 954 kg) | 28,074 lb (12 734 kg) | 27,817 lb (12 618 kg) | 29,706 lb (13 474 kg) |
| Loader clearance circle with bucket | 497.0 in (12 624 mm) | 499.9 in (12 697 mm) | 496.0 in (12 598 mm) | 498.8 in (12 670 mm) |

721G

| | | | | |
|---|---|---|---|---|
| Maximum rollback: | | | | |
| Ground | 58° | 58° | 58° | 58° |
| Carry position | 58° | 58° | 58° | 58° |
| @ Full height | 58° | 58° | 58° | 58° |
| Maximum grading angle with bucket – back dragging | 61° | 62° | 60° | 62° |
| SAE bucket capacity – struck | | | | |
| Heaped | 2.56 yd ³ (1.96 m ³) | 2.42 yd ³ (1.85 m ³) | 2.56 yd ³ (1.96 m ³) | 2.42 yd ³ (1.85 m ³) |
| Heaped | 3.00 yd ³ (2.29 m ³) | 2.80 yd ³ (2.14 m ³) | 3.00 yd ³ (2.29 m ³) | 2.80 yd ³ (2.14 m ³) |
| Bucket width – outside | 106.3 in (2 700 mm) | 106.8 in (2 713 mm) | 106.3 in (2 700 mm) | 106.8 in (2 713 mm) |
| Bucket weight | 3,648 lb (1 655 kg) | 3,545 lb (1 608 kg) | 3,179 lb (1 442 kg) | 3,077 lb (1 396 kg) |

NOTE: *Z-Bar performance data shown with full counterweight.

Performance data unit equipped with 20.5-R25 L3 Radial tires, ROPS cab with heater and A/C, full counterweight, standard batteries, front and rear fenders, full fuel and 165 lb (75 kg) operator. Specifications per SAE J732, J1234, J695, J742 and J818.

STANDARD EQUIPMENT

OPERATOR ENVIRONMENT

See page 1

ENGINE

Case/FPT F4HFE613T
Tier 4 Final Certified
Selective Catalytic Reduction (SCR) with Diesel Oxidation Catalyst
Selectable work modes:
Maximum Power
Standard Power
Economy Power
Auto Power
Turbocharger
Charge air cooling
Automatic belt tensioner
Integral engine oil cooling
Fuel filter with water trap
Dual-element dry-type air cleaner
Hydraulic-driven cooling fan
Air-cooled radiator
Mid-mounted cooling module
Common rail electronic fuel injection

LOADER

See page 2 – Operating weight,
Other specifications

DRIVETRAIN

4-wheel drive
4F/3R Selectable autoshift/manual shift transmission
Electronic Control Module – programmable, computer controlled proportional shifting with programmable gear selection

Onboard diagnostics
Single lever electronic shift control
F/N/R switch in loader control handle
Downshift button
Torque converter
Limited-slip differentials
Outboard planetary axles
Transmission oil cooler
Brake pedal transmission disconnect – declutch
Hydraulic wet disc brakes
Spring-applied hydraulic release parking brake
Limp-Home Mode
Greaseable rear axle trunnion
3-piece rims

HYDRAULICS

Electro-hydraulic (EH) joystick loader control
Low-effort steering
Hydraulic driven cooling fan
Diagnostic quick couplers
Split flange hydraulic connections – 1 in or greater
Hydraulic oil cooler

ELECTRICAL

Alternator and voltage regulator
Battery isolator/electrical disconnect
120 amp alternator
(2) 700 CCA 12-volt batteries
Electric starter
Lights:
2 Front and 2 rear halogen flood lights
2 Front driving headlights – high/low beam with integrated turn signals
2 LED stop/tail lights with integrated turn signals
Key start/stop switch
Backup alarm
Centrally located fuse box with all electrical circuits protected
Remote jump start posts

OTHER

Electric hood lift
Front and rear fenders, partial coverage
Heavy counterweight
Drawbar hitch
Articulation locking bar
Lift arm locking bar
Lift and tie-down points – front/rear
Grouped remote-mounted ecology drains:
Engine oil
Engine coolant
Hydraulic oil

TELEMATICS

CASE SiteWatch™ Telematics – includes hardware and a 3-yr Advanced data subscription

OPTIONAL EQUIPMENT

OPERATOR ENVIRONMENT

Cloth-covered heated air-suspension seat
Leather trimmed heated air seat with active suspension
Cloth mechanical suspension seat
Headrest
3 in (76 mm) retractable seat belt
Sound Shield noise suppression package
Bluetooth radio, 12V AM/FM with auxiliary input
Radio-ready – 12 or 24-volt with auxiliary power – 12-volt
Cab convenience package:
Rear sun shade, interior mirror, under the seat drawer, coat hook, 12V accessory port, and an ash tray
In cab powered cooler box
In cab accessory mount
LED rotating beacon
Rear view camera
External rear view mirrors
External heated rear view mirrors
Front LED driving/headlights
LED front and rear work lights
Extra front-facing LED work lights

DRIVETRAIN

5F/3R Autoshift/manual shift transmission, lockup torque converter, PowerInch de-clutch
Heavy-duty axles:
With locking front differential and rear open differential
Cold weather package:
Heavy-duty (2) 950 CCA 12V batteries
Grid heater
Fuel heater
Hydraulic oil cooler bypass
Low temperature hydraulic oil
Fast-warm hydraulic valve

HYDRAULICS

Auxiliary hydraulics
Ride Control™
Secondary steering
Joystick steering with and without secondary steering
2-function loader valve with single access control
3-function loader valve with 3 lever control or with joystick plus lever

LOADER

XR extended reach version
XT tool carrier version
Attachment auxiliary hydraulics
Coupler systems – JRB or ACS compatible
Buckets – see pages 4 through 8
4 – 1 clamp buckets
Forks

TIRES

20.5-25 16 PR L2 bias – dirt/traction
20.5-25 16 PR L3 bias – rock
20.5-R25 L2 radial – dirt/traction
20.5-R25 L3 radial – rock
20.5-R25 radial Michelin SnoPlus
20.5-R25 radial Bridgestone Snow Wedge
SolidFlex HD solid tires on adapter rims
Spare wheels and tires
Axle oscillation stops

GUARDING

Skid plate, transmission and front chassis bottom guards
Windscreen guard
Specialized guarding package:
Windscreen, articulation, front cover, chassis bottom, skid plate, transmission, lift cylinder, front lights, fuel tank, metal wrapped hoses and cylinder debris ejectors

ADVANCED ENGINE AIR FILTRATION

Heavy Debris cooling system:
Slanted cooling module cover
Auto reversing fan
Increased cooling fin spacing
Added cooling module sealing
Variable speed hydraulic reversing fan
Full-view air pre-cleaner
Sy-Klone® ejector type pre-cleaner

OTHER

Additional RH steps and platform w/ standard or wide fenders
Side guards for rear frame
Tool box – ground level access
Light counterweight – Z-Bar
Fire extinguisher
License plate bracket
12.4 mph (20 kph) maximum speed control
Special paint
Standard fenders with right and left hand steps
Wide full coverage fenders with right and left hand steps

CaseCE.com

©2017 CNH Industrial America LLC. All rights reserved. CASE is a trademark registered in the United States and many other countries, owned by or licensed to CNH Industrial N.V., its subsidiaries or affiliates. CNH Industrial Capital is a trademark in the United States and many other countries, owned by or licensed to CNH Industrial N.V., its subsidiaries or affiliates. Printed in U.S.A. Contains 10% post-consumer fiber.

IMPORTANT: CASE Construction Equipment Inc. reserves the right to change these specifications without notice and without incurring any obligation relating to such change. Availability of some models and equipment builds vary according to the country in which the equipment is used. The illustrations and text may include optional equipment and accessories and may not include all standard equipment. Your CASE dealer/distributor will be able to give you details of the products and their specifications available in your area.



CASE Construction Equipment is biodiesel-friendly. NOTE: All engines meet current EPA emissions regulations. All specifications are stated in accordance with SAE Standards or Recommended Practices, where applicable.



Always read the Operator's Manual before operating any equipment. Inspect equipment before using it, and be sure it is operating properly. Follow the product safety signs and use any safety features provided.

Form No. CCE201708721G
Replaces Form No. CCE201610721G

721G

10 of 10