



580 Super D Construction King®



60 (44.7 kW) NET FLYWHEEL HORSEPOWER

Case-built turbocharged four cylinder 207 in³ (3392 cm³) high torque diesel with matching power train and high capacity brakes.

FIELD PROVEN SYNCHRONIZED TRANSMISSION

Four speed with power shuttle and torque converter.

CHOICE OF BACKHOES

14' 7" (4.45 m) backhoe or 14' 9.5"-18' 9" (4.51 m-5.72 m) telescoping Extendahoe™. Over-center backhoe transport position for loading and roading stability.

5155 LB (2338 kg) LIFT CAPACITY SELF-LEVELING LOADER

Single lever controls bucket rollback, lift, dump, lower, float and return to dig.

"PRIORITY" DEMAND PERFORMANCE— TANDEM GEAR PUMP HYDRAULICS

Provides flow to the loader, backhoe and steering valve. Gives optimum speed or power upon demand.

UNITIZED MAIN FRAME

Absorbs heavy shock loads, maintains power train alignment, simplifies servicing.

COMPONENTIZED POWER TRAIN

Permits servicing of individual components without disturbance of the rest of the drive line.

OPERATOR CONVENIENCE

Roomy work platform. Isolated with rubber mounts to reduce noise and vibration. Sloping hood and grille and 4-way adjustable seat improves visibility and operator efficiency.

Unit shown is equipped with non-standard items.

J I Case

A Tenneco Company



700 State Street Racine, WI 53404 U.S.A.

Specifications

580 Super D Tractor

Construction King®

ENGINE

Make and Model	Case G207DT diesel
Type of fuel	No. 2 diesel
No. of cylinders	4
Bore and stroke	4" x 4.125" (102 mm x 105 mm)
Displacement	207 in ³ (3392 cm ³)
Compression ratio	16.5:1
Fuel induction	Injectors
Fuel supply	Injection pump
Air cleaner	Dry type—replacement element
Oil filter	Replaceable spin-on cartridge, full flow
Lubrication	Positive pressure
Cooling system	Pressurized—7 psi (48 kPa)
Horsepower	
Gross (1)	66 (at 2200 rpm 49.2 kW (at 2200 r/min))
SAE Net (2)	60 (at 2200 rpm 44.7 kW (at 2200 r/min))
Max. torque ft-lb (Nm)	
Gross (1)	178 (at 1400 rpm 241 Nm (at 1400 r/min))
SAE Net (2)	173 (at 1400 rpm 235 Nm (at 1400 r/min))

(1) Gross engine horsepower or torque at flywheel per SAE J270 specification.
 (2) Net engine horsepower or torque at flywheel per SAE J270 specification.

POWER CURVE

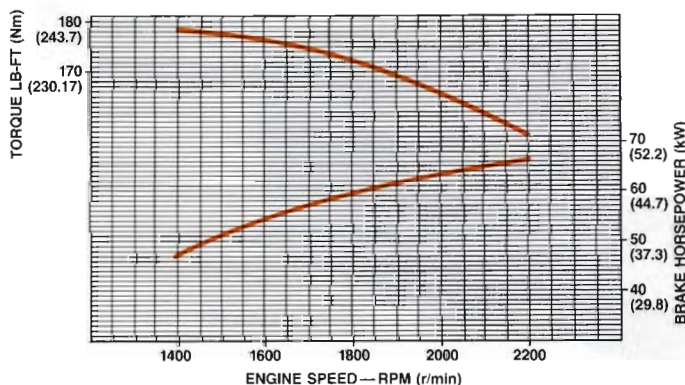

ELECTRICAL

System voltage	12 volts, negative ground
Battery	Maintenance free, 700 cold cranking amps at 0°F (-18°C)
Alternator	42 amp

POWER TRAIN

Transmission: 4 speed sliding spur and helical gears with power shuttle and torque converter. Permits on-the-go shifting up from 2nd to 3rd to 4th and down from 4th to 3rd.

Torque converter: Single stage hydrokinetic type (2.78 to 1 ratio).

Reversing unit: Power hydraulic clutches.

Brakes: Individual or simultaneous foot actuated, hydraulic self-adjusting. 8" (203 mm) double disc. Over-center hand-operated parking brake.

Final drives: Multiple gear reduction.

AXLES RATINGS

FRONT	
Dynamic	44,000 lbs (19 950 kg)
Static	11,500 lbs (5216 kg)
REAR	
Dynamic	54,000 lbs (24 494 kg)
Static	13,500 lbs (6123 kg)

STEERING

Power steering	Hydrostatic
Hydraulic pump	Front mounted, positive displacement, gear type, tandem pump
Pump capacity	7.3 gpm (at 2300 rpm (at 2000 psi 28 l/min (at 2300 r/min (at 13 790 kPa))
Main relief setting	2100 ± 50 psi (14 479 ± 345 kPa)
Turning ratio (stop to stop)	2.75 turns
Steering cylinders (2)	1.5" dia x 6.5" stroke double acting. (38 mm dia x 165 mm stroke)

SERVICE CAPACITIES

	U.S.	Litres
Cooling system		
w/heater	13 qt 15 oz	12.75
w/o heater	12 qt 26 oz	12.1
Fuel tank	22 gal	83
Engine oil		
w/filter	9 qt	8.5
w/o filter	8 qt	7.6
Power shuttle	8 qt	7.6
Transaxle	20 qt	18.9
Hydraulic reservoir		
w/filter	12.5 gal	47.3
w/o filter	12 gal	45.4

TRAVEL SPEEDS—MPH (km/h)

Engine at full throttle, 17.5L x 24, R4 rear tires.

	FIRST	SECOND	THIRD	FOURTH
Forward	3.5 (5.6)	6.5 (10.5)	12.2 (19.6)	21.5 (34.6)
Reverse	3.1 (5.0)	6.0 (9.7)	11.1 (17.9)	19.6 (31.5)

580 SUPER D TIRES

	SIZE	PLY RATING	TREAD	PRESSURE PSI (kPa)
FRONT	7.50 x 16	10	(I1) rib	56 (386)
	8.00 x 16	10	(F3) truck tread	56 (386)
	11L x 16	10	(F3) truck tread	48 (331)
REAR	14.9 x 24	6	(R4) utility traction	20 (138)
	14.9 x 24	8	(R4) utility traction	24 (165)
	16.9 x 24	6	(R4) utility traction	18 (124)
	*16.9 x 24	8	(R4) utility traction	24 (165)
	17.5L x 24	6	(R4) industrial suregrip	16 (110)
	*17.5L x 24	8	(R4) industrial suregrip	22 (152)

*Must be used on machines equipped with Extendahoe. May also be used on machines equipped with 14' 7" (4.45 m) backhoe.

TURNING CLEARANCE CIRCLE

With brakes	21' 2" (6.45 m)
Without brakes	24' 1" (7.34 m)

580 Super D Loader

HYDRAULIC SYSTEM

Hydraulic pump: Front mounted, positive displacement, gear type, tandem pump.

Pump capacity: 24 gpm @ 2300 rpm @ 2000 psi
(90 l/min @ 2300 r/min @ 13 790 kPa).

Control valve main relief pressure: 2450 psi (16 892 kPa).

Filtration: 15 micron, full flow replaceable cartridge on return line. Condition indicator light for filter.

Loader control valve: Mono cast two or three spool. Single lever control for lift and tilt. Lift lever has positive hold "float" position and "return-to-dig" feature.

Hydraulic lines: Steel tubing with brazed or flared fittings and wire braid, high pressure hose with crimped, full flow fittings.

Loader cylinders:

- Lift (2) 3" dia x 31.5" stroke, 1.75" rod
(76 mm dia x 800 mm stroke, 44 mm rod)
- Tilt (2) 2.5" dia x 20" stroke, 1.5" rod
(64 mm dia x 508 mm stroke, 38 mm rod)
- Clam (2) 3" dia x 9" stroke, 1.75" rod
(76 mm dia x 229 mm stroke, 44 mm rod)

LOADER BUCKET SIZES (Capacities SAE)

WIDTH		TYPE	HEAPED		STRUCK	
In	m		yd ³	m ³	yd ³	m ³
74	1.88	Short lip	.75	.60	.70	.50
82	2.08	Long lip	1.00	.76	.87	.67
82	2.08	4-in-1	1.00	.76	.81	.62

OPERATIONAL DATA (General Purpose Bucket)

Lift capacity to full height 5155 lbs (2338 kg)
 Height to bucket hinge pin-raised 10' 9.4" (3.29 m)
 Bucket rollback at ground line 40°
 Breakout force 7600 lbs (33 806 N)
 Dump angle at full height 45°
 Grading angle 110°

	SHORT LIP	LONG LIP
Digging depth below ground line—bucket flat	3.25" (83 mm)	3.25" (83 mm)
Dump clearance at full height 45° dump	8' 7.75" (2.64 m)	8' 4" (2.54 m)
Dump reach at full height 45° dump	25.5" (648 mm)	28" (711 mm)
Reach—bucket on ground	5' 10.8" (1.80 m)	6' 4.6" (1.95 m)
Raising time to full height	5.2 sec	5.2 sec
Bucket dumping time	1.0 sec	1.0 sec
Lowering time, power down	3.0 sec	3.0 sec
Return-to-dig	4.1 sec	4.1 sec

OPERATIONAL DATA (4-in-1[®] Bucket)

Lift capacity to full height 4390 lbs (1991 kg)
 Height to bucket hinge pin 10' 8.5" (3.27 m)
 Bucket rollback at ground line 46°
 Breakout force 7040 lbs (31 315 N)
 Dump angle at full height 52°
 Grading angle—clam closed 103°
 Digging depth below ground line
 —bucket flat 5.25" (133 mm)
 Digging depth—using clam 47" (1.19 m)
 Digging depth—clam open 5" (127 mm)
 Dump clearance at full height
 52° dump—clam 10' 0.25" (3.05 m)
 52° dump—bucket 8' 6.75" (2.61 m)
 Dump reach at full height—52° dump 27" (686 mm)
 Reach-bucket on ground 6' 5" (1.95 m)
 Raising time to full height 5.2 sec

Bucket dumping time 1 sec
 Return-to-dig 4.1 sec
 Width of dozer cutting edge 6' 9.5" (2.07 m)
 Maximum clam opening 3' 1.3" (947 mm)
 Moldboard height 3' 0" (914 mm)

TURNING CLEARANCE CIRCLE

Bucket rollback—hinge pin at SAE carry position
 With brakes 30' 3.25" (9.23 m)
 Without brakes 32' 5" (9.88 m)

THREE POINT MOD HITCH

Hydraulic pump: Front mounted, positive displacement, gear type, tandem pump.

Pump capacity: 7.3 gpm @ 2300 rpm @ 2000 psi
(28 l/min @ 2300 r/min @ 13 790 kPa).

Control valve: 4 spool sectional valve for hydraulic control of lift, tilt, pitch and auxiliary with "float" detent in the lift spool. Single spool sectional valve for hydraulic control of lift and mechanical adjustment of tilt and pitch. The main relief valve in this system is adjusted lower than the loader system pressure.

Mod hitch cylinders:

- Lift (1) 3" dia x 8.4" stroke, 1.5" rod
(76 mm x 214 mm stroke, 38 mm rod)
- Tilt (1) 2.5" dia x 6.31" stroke, 1.25" rod
(64 mm x 160 mm stroke, 32 mm rod)
- Pitch (1) 2.5" dia x 7" stroke, 1.25" rod
(64 mm x 178 mm stroke, 32 mm rod)



580 Super D Backhoe

HYDRAULIC SYSTEM

Hydraulic pump: Front mounted, positive displacement, gear type, tandem pump.

Pump capacity: 7.3 gpm (2300 rpm @ 2000 psi)
 (28 l/min @ 2300 r/min @ 13 790 kPa)
 24 gpm (2300 rpm @ 2000 psi)
 (90 l/min @ 2300 r/min @ 13 790 kPa)
 31.3 gpm combined (2300 rpm @ 2000 psi)
 (118 l/min combined @ 2300 r/min @ 13 790 kPa).

Control valve main relief: 2450 psi (16 892 kPa).

Unloading valve setting: 2300 psi (15 858 kPa).

Filtration: 15 micron, full flow replaceable cartridge on return line. Condition indicator light for filter.

Backhoe control valve: Sectional four spool valve — boom, dipper, bucket, and swing. Foot or optional hand swing. Regeneration and hydraulic cushioned swing stops. Mono-cast two spool stabilizer valve with pilot checks.

Hydraulic lines: Steel tubing with brazed or flared fittings and wire braid high pressure hose with crimped, full flow fittings.

Backhoe cylinders:

- Stabilizers (2) 4" dia x 21.77" stroke, 2" rod
 (102 mm dia x 553 mm stroke, 51 mm rod)
- Swing (2) 4" dia x 11.2" stroke, 2" rod
 (102 mm dia x 285 mm stroke, 51 mm rod)
- Boom (2) 3.2" dia x 42.1" stroke, 1.75" rod
 (83 mm dia x 1.07 m stroke, 44 mm rod)
- Dipper (1) 4" dia x 33.87" stroke, 2.5" rod
 (102 mm dia x 860 mm stroke, 64 mm rod)
- Bucket (1) 3.5" dia x 30.56" stroke, 2.5" rod
 (89 mm dia x 776 mm stroke, 64 mm rod)
- Dipper extension (1) 3" dia x 48" stroke, 1.5" rod
 (76 mm dia x 1.22 m stroke, 38 mm rod)

LIFT CAPACITY CHART—14' 7" (4.45 m) Backhoe*

1. Lift capacity figures on this chart are 87% of the maximum lift force per SAE Definition J31 and J49 at 2450 psi (16 892 kPa) system relief pressure.
2. Top numbers/lift capacity within 45° either side of prime mover.
3. Bottom number/lift capacity anywhere within full swing arc.
4. *Figures are stability limited and 75% of tipping load.
5. Figures stated are determined by static tests and do not include dynamic factors.

*For Extendahoe lift capacities refer to operator's manual.

OPERATIONAL DATA—14' 7" (4.45 m) Backhoe and 14' 9.5"-18' 9" (4.51 m-5.72 m) Extendahoe®

	14' 7" (4.45 m) Backhoe	14' 9.5"-18' 9" (4.51 m-5.72 m) Extendahoe®
Digging depth—SAE	14' 7" (4.45 m)	14' 9.5" (4.51 m)
Overall reach from rear axle centerline	21' 6.8" (6.47 m)	21' 8" (6.50 m)
Digging radius from swing pivot	18' (5.40 m)	18' 2" (5.54 m)
Loading height	11' 5.3" (3.43 m)	12' 1" (3.60 m)
Loading reach	47" (1.18 m)	47.4" (1.19 m)
Swing arc	180°	180°
Bucket rotation—#1 position	168°	164°
#2 position	151°	148°
Stabilizer spread—operating position	9' 0.25" (2.75 m)	9' 0.25" (2.75 m)
Stabilizer spread—transport position	6' 8.6" (2.05 m)	6' 8.6" (2.05 m)
Stabilizer angle— from straight	20°	20°
Digging force, bucket cylinder, SAE	10,446 lbs (46 466 N)	10,548 lbs (46 920 N)
Digging force, dipper cylinder, SAE	6014 lbs (26 752 N)	5835 lbs (25 955 N)
Leveling angle (maximum slope on which backhoe will make vertical cut)	12°	12°

DIG DEPTH CHART

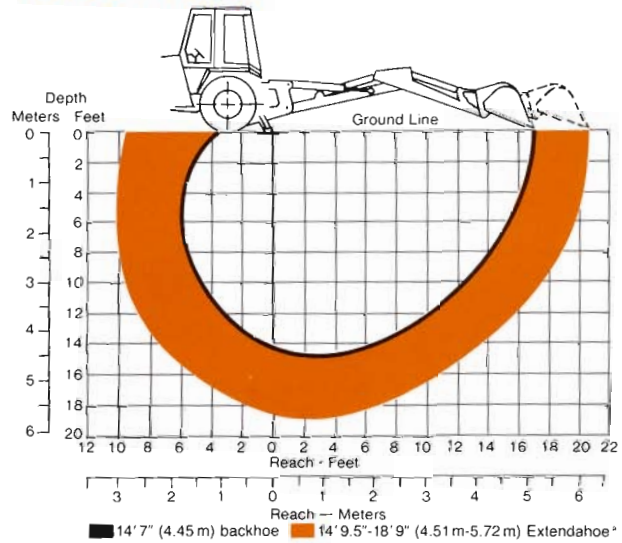

LIFT CAPACITY CHART

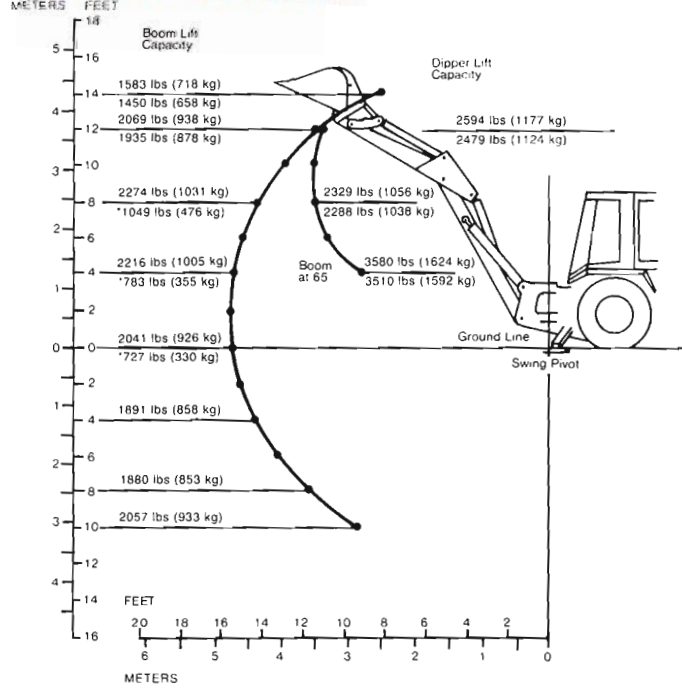

(g)
(g)

(g)
(g)

itic
nt,
mp
psi
'a)
'a)
ns
ke
(e)

es

75

2.1

83

3.5

7.6

7.6

3.9

7.3

5.4

H

(.6)

(.5)

RE

a)

i)

i)

i)

i)

i)

i)

)

2)

d

m)

m)

580 Super D Dimensional Data

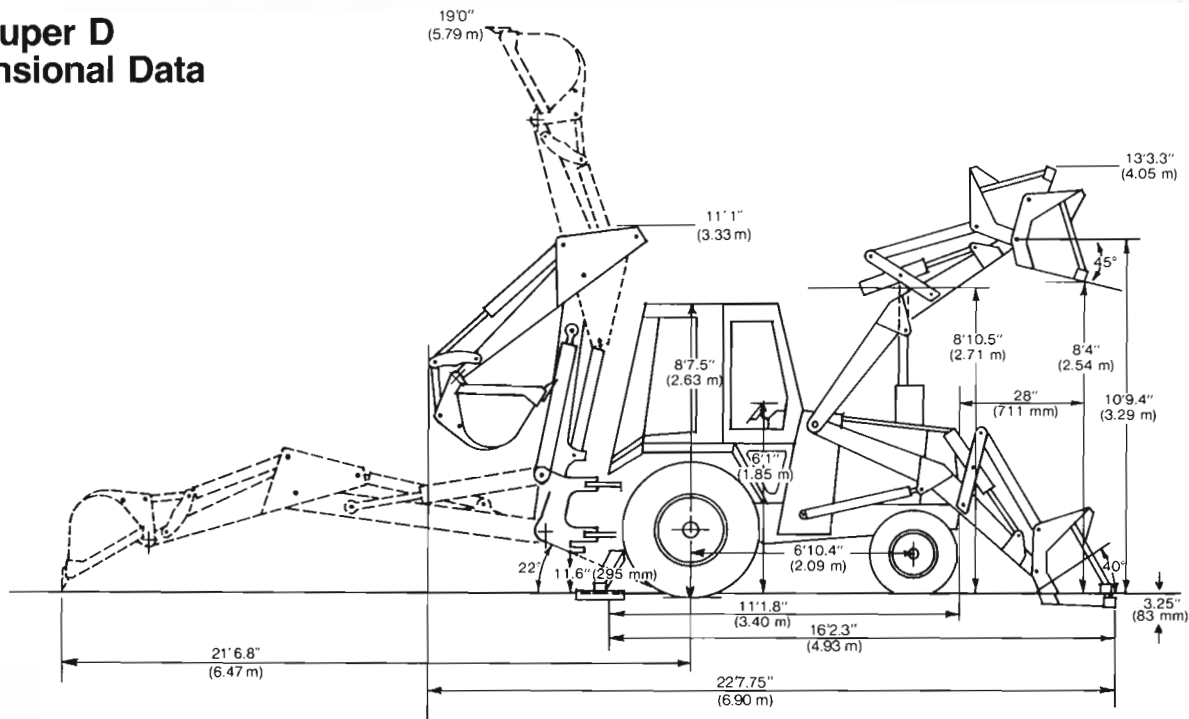

TRACTOR

Overall length	11' 1.8" (3.40 m)
Overall width	6' 6.2" to 6' 8.8" (1.97 m to 2.05 m)
Height: to top of canopy	8' 7" (2.62 m)
Height: to top of cab	8' 7.5" (2.63 m)
Height: to top of exhaust stack	8' 10.5" (2.71 m)
Height: to top of steering wheel	6' 1" (1.85 m)
Ground clearance (tractor main frame)	9.125" (232 mm)
Front wheel tread	4' 11" or 5' 2" (1.5 m or 1.6 m)
Rear wheel tread	5' 2" (1.6 m)
Wheel base	6' 10.4" (2.09 m)

LOADER

	GENERAL PURPOSE BUCKET	SHORT LIP	LONG LIP
Overall length	15' 9.2" (4.80 m)	16' 2.3" (4.93 m)	16' 2.3" (4.93 m)
Overall width	6' 9" (2.06 m)	6' 10" (2.08 m)	6' 10" (2.08 m)
Overall operating height	13' 3.3" (4.05 m)	13' 3.3" (4.05 m)	13' 3.3" (4.05 m)
Digging depth below ground—bucket flat	3.25" (83 mm)	3.25" (83 mm)	3.25" (83 mm)
Height to bucket hinge pin	10' 9.4" (3.29 m)	10' 9.4" (3.29 m)	10' 9.4" (3.29 m)
Dump angle at full height	45°	45°	45°
Dump clearance full height			
45° dump	8' 7.8" (2.64 m)	8' 4" (2.54 m)	8' 4" (2.54 m)
Dump reach at full height			
45° dump	25.5" (648 mm)	28" (711 mm)	28" (711 mm)
Bucket rollback at ground line	40°	40°	40°

4-in-1 BUCKET

Overall length	16' (4.88 m)
Height to bucket hinge pin	10' 8.5" (3.26 m)
Digging depth below ground—bucket flat	5.25" (133 mm)
Dump angle at full height	52°
Dump clearance at full height	
52° dump—clam	10' 0.25" (3.05 m)
—bucket	8' 6.75" (2.61 m)

Dump reach at full height	
52° dump	27" (686 mm)
Bucket rollback at ground line	46°

BACKHOE

	14' 7" (4.45 m)	EXTENDAHOE*	
		RETRACTED	EXTENDED
Overall length—transport	22' 7.75" (6.90 m)	22' 3.90" (6.80 m)	N/A
Short lip bucket	22' 7.75" (6.90 m)	22' 9" (6.93 m)	N/A
Long lip bucket	22' 3.75" (6.74 m)	22' 6.5" (6.87 m)	N/A
Overall reach from rear axle centerline	21' 6.8" (6.47 m)	21' 8" (6.50 m)	25' 6" (7.65 m)
Overall height, maximum	19' 0" (5.79 m)	18' 10.5" (5.75 m)	22' 5" (6.83 m)
Transport height	11' 1" (3.33 m)	11' 4" (3.40 m)	N/A
Overall width—transport	6' 10" (2.08 m)	6' 10" (2.08 m)	6' 10" (2.08 m)
Ground clearance at backhoe main frame	11.6" (295 mm)	11.3" (287 mm)	11.3" (287 mm)
Angle of departure	22°	21°	21°

NOTE: Specifications taken with 11L x 16, 10 PR front tires, 17.5L x 24, 6PR rear tires, ROPS canopy, 14' 7" (4.45 m) backhoe with 24" (610 mm) high-capacity trenching bucket, loader with 82" (2.08 m) long lip bucket and standard equipment unless otherwise specified.

Equipment Attachments

STANDARD EQUIPMENT

TRACTOR

Air cleaner, dry type with replaceable cartridges • Anti-freeze solution to -20°F (-29°C) • Axle (front), heavy-duty with 59" (1.50 m) fixed tread • Brakes, hydraulic • Brake, parking, over-center • Electrical system, 12 volt • Engine, turbocharged 60 net hp (44.7 kW) Case G207DT diesel • Fenders, rear • Floor plates • Fuel opening, lockable • Gauges and Instruments: air cleaner restriction light, alternator charge warning lamp, condition light for loader and backhoe hydraulic system filter, converter temperature gauge, engine oil pressure warning light, engine water temperature gauge, fuel level gauge, hourmeter, tachometer, voltmeter • Grille, heavy-duty • Headlights (two shock mounted), one rear working and one red tail • Instrument cluster, illuminated • Muffler, upright oval with deflector • Oil cooler, hydraulic • Oil filter, full flow • Power shuttle, with torque converter, 4-speed transaxle with differential lock • Radiator opening, lockable • Reservoir, common for steering, loader and backhoe • ROPS canopy on isolated operator's compartment • Safety belt, seat mounted • Seat, Easy Ride with single lever turn-around adjustment • Side panels, full length of engine, lockable • Steering, hydrostatic • Throttle, hand and foot • Tires (front) 7.50 x 16, 10 PR, I1 • Tires (rear), 14.9 x 24, 6PR, R4 utility traction tread • Toolbox • Wrapper, front.

LOADER

All tractor standard equipment • Single lever control • Hydraulic system, complete • Indicator, bucket level • Loader (less bucket) • Return-to-dig • Self-leveling • Support strut, lift arm.

14'7" (4.45 m) BACKHOE

All tractor and loader standard equipment • Hydraulic system, complete, including three lever, footswing control • Over-center backhoe (less bucket) Model 35B with quick disconnect mounting • Stabilizers with two position cleated pads.

14'9.5"-18'9" (4.51 m-5.72 m) EXTENDAHOE®

All tractor, loader and backhoe equipment • Hydraulic telescoping extendahoe accessory hydraulics and front counterweight.

OPTIONAL EQUIPMENT

TRACTOR

Air conditioning • Alarm, backup • Anti-freeze to -40°F (-40°C) • Beacon, rotating • Drawbar, swinging or rigid • Emblem, SMV • Floor mat • Full lockup package • Hitch, modular 3-point • Horn • Lights, combination tail, stop, directional and flasher (canopy only) • Muffler, spark arresting • Paint, special • ROPS cab with air filtration, defogger, heater and pressurization • Seat, deluxe • Start kit, cold weather • Tires, various sizes — see tractor section • Weights, front end.

LOADER

All tractor optional equipment • Accessory hydraulics • Bucket teeth • Rear counterweight • 82" (2.08 m) long lip bucket, 74" (1.88 m) short lip bucket, 82" (2.08 m) 4-in-1* bucket.

BACKHOE

All tractor and loader optional equipment • Backhoe floor mat • Boom lockout • Counterweight, front • Dual lever backhoe controls • Street-cemetery stabilizer pads • 12" (305 mm), 18" (457 mm), 24" (610 mm), 30" (714 mm) standard duty trenching buckets • 18" (475 mm), 24" (610 mm), 30" (762 mm), 36" (914 mm) heavy-duty trenching buckets • 24" (610 mm) Hi-capacity bucket.

APPROXIMATE SHIPPING WEIGHTS

NOTE: Specifications taken with 11L x 16 front tires, 17.5L x 24 rear tires, ROPS canopy and standard equipment unless otherwise specified.

TRACTOR

Drawbar tractor w/ROPS canopy 6230 lbs (2826 kg)
 Drawbar tractor w/ROPS cab 6550 lbs (2971 kg)
 Air conditioning add 30 lbs (13.6 kg)

TRACTOR W/LOADER (Less Bucket)

Without rear counterweight 7580 lbs (3438 kg)
 Rear counterweight (required
 with no rear attachments) add 1495 lbs (678 kg)

LOADER BUCKETS (Optional)

74" (1.88 m) short lip 600 lbs (272 kg)
 82" (2.08 m) long lip 760 lbs (345 kg)
 82" (2.08 m) 4-in-1" 1130 lbs (513 kg)

TRACTOR/LOADER W/BACKHOE (Less Buckets)

14'7" (4.45 m) backhoe 10,655 lbs (4833 kg)
 Extendahoe® 11,364 lbs (5155 kg)
 Front counterweight (required w/extendahoe)
 add 800 lbs (363 kg)

BACKHOE BUCKETS (Optional)

	Standard Trenching	Heavy-Duty Trenching
12" (305 mm)	198 lbs (90 kg)	N/A
18" (457 mm)	238 lbs (108 kg)	322 lbs (146 kg)
24" (610 mm)	270 lbs (122 kg)	380 lbs (172 kg)
30" (762 mm)	306 lbs (139 kg)	410 lbs (186 kg)
36" (914 mm)	346 lbs (157 kg)	458 lbs (208 kg)
24" (610 mm)	405 lbs (184 kg)	(special high capacity trenching bucket)

MOD HITCH

3 point hitch 700 lbs (321 kg)

Extendahoe, 4-in-1 and Construction King are trademarks of the J I Case Company.

NOTE: All specifications are stated in accordance with ICED definitions or SAE standards or recommended practices, where applicable.

IMPORTANT

J I Case Company reserves the right to change these specifications without notice and without incurring any obligation relating to such change.

Sold and serviced by: