

# Loader/Backhoe

Choice of 2-wheel or 4-wheel-drive  
Case 90 net horsepower (67 kW) diesel  
Lift to 7200 lbs (3266 kg), dig to 20'7" (6.27 m)

# 680L



**Case**<sup>®</sup>

680L

# 680L Basic Tractor

## Engine

Make and model . . . . . Case 6-590  
 Type of fuel . . . . . No. 2 diesel  
 No. of cylinders . . . . . 6  
 Bore and stroke . . . . . 4.02" x 4.72"  
 (102 mm x 120 mm)  
 Displacement . . . . . 359 in<sup>3</sup> (5883 cm<sup>3</sup>)  
 Compression ratio . . . . . 17.5 to 1  
 Fuel induction . . . . . Open chamber,  
 direct injection  
 Fuel supply . . . . . Injection pump  
 Air cleaner . . . . . Dry type—  
 replaceable elements  
 Oil filter . . . . . Replaceable, spin on full  
 flow cartridge  
 Lubrication . . . . . Positive pressure  
 Cooling system . . . . . Air, water w/lube  
 oil cooler

Horsepower  
 (1) Gross . . . . . 101 @ 2200 rpm  
 (75.3 kW @ 2200 r/min)  
 (2) SAE Net . . . . . 90 @ 2200 rpm  
 (67.1 kW @ 2200 r/min)

Max. torque ft-lb  
 (1) Gross . . . . . 273 @ 1200 rpm  
 (370.1 Nm @ 1200 r/min)  
 (2) SAE Net . . . . . 265 @ 1200 rpm  
 (359.3 Nm @ 1200 r/min)

(1) Gross engine horsepower or torque at flywheel per SAE Standard J1349.  
 (2) Net engine horsepower or torque at flywheel per SAE Standard J1349

## Power Curve

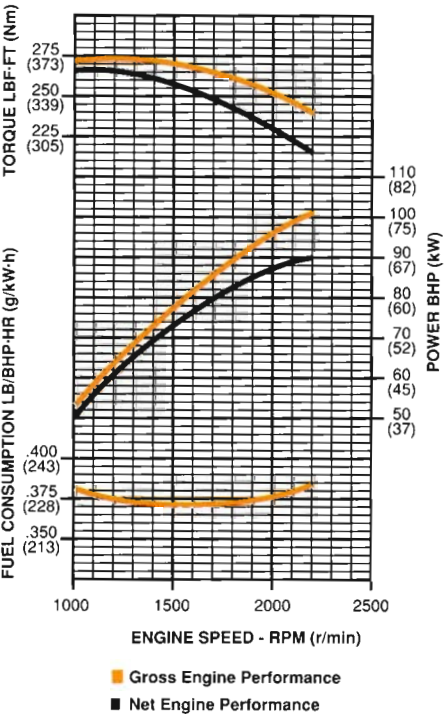

## Electrical

System voltage . . . . . 12-volts  
 negative ground  
 Battery (2) . . . . . 12-volt, low maintenance,  
 685 cold cranking amps at 0°F (-18°C)  
 Alternator . . . . . 65 amp

## Power Train

Transmission: 3 speed powershift with power shuttle and torque converter.  
 Torque converter: Single state hydrokinetic type (2.85 to 1 ratio).  
 Reversing unit: Full power hydraulic clutches.  
 Brakes: Individual or simultaneous foot-actuated, wet disc that are self-adjusting and self-equalizing [175 in<sup>2</sup> (1129 cm<sup>2</sup>) of braking surface per wheel]. Brakes can be operated without interrupting power flow to the rear wheels. A clutch cut out is located on the loader control handle. Automatic, spring-applied, hydraulic-released, parking brake is transmission mounted.  
 Final drives:  
 Front (4WD) . . . . . Outboard planetaries  
 Rear . . . . . Outboard planetaries with differential lock.

4-wheel drive: Operator engaged front-wheel mechanical drive by a cable located under the steering wheel.

## Axle Ratings (Manufacturers)

	*Front	Rear
Maximum static	70,096 lbs. (31 796 kg)	98,096 lbs. (44 496 kg)
Operating static	19,446 lbs. (8821 kg)	26,977 lbs. (12 237 kg)
Operating dynamic	38,829 lbs. (17 613 kg)	53,954 lbs. (24 474 kg)

\*applies for both 2WD and 4WD

## Axle Oscillation

Front: (2WD) . . . . . 12°/side—24° total  
 (4WD) . . . . . 12°/side—24° total  
 Rear . . . . . Fixed

## Steering

Power steering . . . . . Hydrostatic  
 Hydraulic pump . . . . . Engine mounted,  
 positive displacement, gear type pump  
 Pump capacity . . . . .  
 18.7 gpm @ 2350 rpm @ 2000 psi  
 (70.8 l/min @ 2350 r/min @ 13 790 kPa)  
 Main relief setting . . . . . 1750 psi  
 (12 066 kPa)

## 2WD

Turning ratio (stop to stop) . . . . . 4.3  
 Steering cylinder, double  
 acting (1) . . . . . 3.35" dia x 4.65" stroke  
 (85 mm dia x 118 mm stroke)

## 4WD

Turning ratio (stop to stop) . . . . . 4.3  
 Steering cylinder, double  
 acting (1) . . . . . 3.35" dia x 4.65" stroke  
 (85 mm dia x 118 mm stroke)

## Service Capacities

	U.S.	Litres
Cooling system . . . . .	6.75 gal	25.6
Fuel tank . . . . .	43 gal	162.8
Engine oil		
w/filter . . . . .	4 gal	15.1
w/o filter . . . . .	3.75 gal	14.2
Transmission . . . . .	4 gal	15.1
Hydraulic reservoir		
w/filter . . . . .	14.2 gal	53.8
w/o filter . . . . .	13.6 gal	51.7
Planetaries		
each (4WD)—Front . . . . .	2.5 qts	2.4
—Rear . . . . .	2.5 qts	2.4
Differential (4WD)		
—Front . . . . .	17 qts	16.4
—Rear . . . . .	18 qts	17.4
Wheel end (2WD) . . . . .	2.1 qts	2.0

## Travel Speeds — mph (KM/h)

Engine at full throttle  
 2-wheel drive with 19.5 x 24 rear tires

	1st	2nd	3rd
Forward or	3.15	6.8	17.5
Reverse	(5.07)	(10.94)	(28.16)

2 and 4-wheel drive with 18.4 x 28 rear tires

	1st	2nd	3rd
Forward or	3.6	7.6	19.6
Reverse	(5.79)	(12.23)	(31.54)

## Tires

Size	Ply Rating	Tread	Pressure PSI (kPa)
<b>FRONT</b>			
14.5/75 x 16.1	10	F3	40 (278)
11 x 16	12	F3 Multi-rib	60 (414)
15 x 19.5*	12	SGL	70 (483)
<b>REAR</b>			
19.5 x 24	12	Ind. S.G.	34 (234)
21L x 24	12	R4	30 (207)
18.4 x 28*	12	R4	32 (221)
21L x 28*	10	R4	28 (193)

\*2 and 4-wheel drive

## Turning Clearance Circle

(Tractor only) — without brakes  
 2WD axle . . . . . 37'7" (11.5 m)  
 4WD axle  
 2WD mode . . . . . 38' (11.6 m)  
 4WD mode . . . . . 40' (12.2 m)

# 680L Loader

## Hydraulic System

Hydraulic pump: Transmission mounted, positive displacement, gear type

Pump capacity:

25.7 gpm @ 2350 rpm @ 2000 psi  
(97.3 l/min @ 2350 r/min @ 13 790 kPa).

Control valve main relief pressure:

2650 psi (18 271 kPa).

Filtration: 10-micron, full flow replaceable cartridge on return line. Condition indicator light for filter.

Loader control valve: Mono-cast two or three spool. Single-lever control for lift and tilt. Separate lever for 4-in-1 bucket. Lift lever has positive hold "float" position and "return-to-dig" feature.

Hydraulic lines: Steel tubing with brazed or flared fittings and wire braid, high pressure hose with crimped, full flow fittings.

Loader cylinders:

Lift (2) . . . . . 4" x 30" stroke, 2.25" rod  
(102 mm dia x 762 mm stroke, 57 mm rod)

Tilt (2) . . . . . 3" dia x 23.6" stroke, 1.75" rod  
(76 mm dia x 598 mm stroke, 44 mm rod)

Clam (2) . . . . . 4" dia x 10" stroke, 2" rod  
(102 mm dia x 254 mm stroke, 51 mm rod)

## Loader Bucket Sizes (Capacities SAE)

In	m	Type	Heaped		Struck	
			yd <sup>3</sup>	m <sup>3</sup>	yd <sup>3</sup>	m <sup>3</sup>
96	2.44	General Purpose	1.50	1.15	1.20	.92
96	2.44	Light Material	1.75	1.34	1.45	1.11
96	2.44	4-in-1	1.25	0.97	1.00	.77
96	2.44	4-in-1	1.50	1.15	1.20	.92

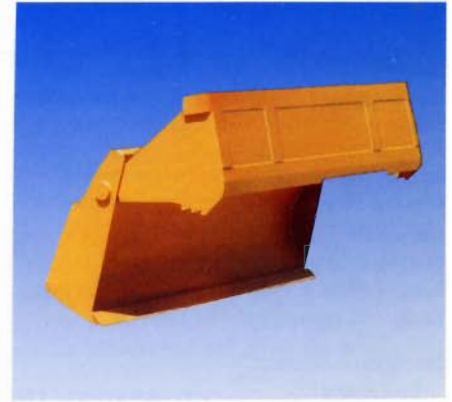

## Operational Data

	General Purpose Buckets		High Density 4-in-1 <sup>®</sup> Bucket	Low Density 4-in-1 <sup>®</sup> Bucket
	1.50 yd <sup>3</sup> (1.15 m <sup>3</sup> )	1.75 yd <sup>3</sup> (1.34 m <sup>3</sup> )	1.25 yd <sup>3</sup> (0.97 m <sup>3</sup> )	1.50 yd <sup>3</sup> (1.15 m <sup>3</sup> )
Lift capacity to full height . . . . .	7200 lbs (3266 kg)	7200 lbs (3266 kg)	5500 lbs (2495 kg)	5500 lbs (2495 kg)
Height to bucket hinge pin-raised . . . . .	11'8" (3.56 m)	11'8" (3.56 m)	11'3.5" (3.44 m)	11'3.5" (3.44 m)
Bucket rollback at groundline . . . . .	38°	38°	40°	40°
Breakout force—combined . . . . .	10,020 lbf (44 571 N)	10,000 lbf (44 482 N)	8320 lbf (37 009 N)	8320 lbf (37 009 N)
Dump angle at full height . . . . .	45°	45°	45°	45°
Grading angle . . . . .	113°	108°	98°	101°
Digging depth below ground line—bucket flat . . . . .	2.5" (64 mm)	2.5" (64 mm)	10" (254 mm)	10" (254 mm)
Digging depth—using clam . . . . .	N.A.	N.A.	N.A.	N.A.
Digging depth—clam open . . . . .	N.A.	N.A.	52" (1.32 m)	52" (1.32 m)
Dump clearance at full height—45° dump . . . . .	9'5" (2.87 m)	9'5" (2.87 m)	N.A.	N.A.
45°—clam . . . . .	N.A.	N.A.	11'2" (3.40 m)	11'5" (3.48 m)
45°—bucket . . . . .	N.A.	N.A.	9'1" (2.77 m)	9'4" (2.85 m)
Dump reach at full height—45° dump . . . . .	31" (787 mm)	31" (787 mm)	38" (965 mm)	37.5" (953 mm)
Dump reach @ 7' (2.13 m) height—45° dump . . . . .	50" (1.27 m)	50" (1.27 m)	54" (1.37 m)	48" (1.22 m)
Width of cutting edge . . . . .	96" (2.44 m)	96" (2.44 m)	96" (2.44 m)	96" (2.44 m)
Maximum clam opening . . . . .	N.A.	N.A.	40.5"	43.5" (1.11 m)
Moldboard height . . . . .	N.A.	N.A.	N.A.	42" (1.07 m)
Raising time to full height . . . . .	5.3 sec.	5.3 sec.	5.3 sec.	5.3 sec.
Bucket dumping time . . . . .	1.6 sec.	1.6 sec.	1.6 sec.	1.6 sec.
Lowering time—power down . . . . .	3.3 sec.	3.3 sec.	3.3 sec.	3.3 sec.
Lowering time—return-to-dig . . . . .	3.6 sec.	3.6 sec.	3.6 sec.	3.6 sec.

# 680L Backhoe

## Hydraulic System

Hydraulic pump: Transmission and engine mounted, positive displacement, gear type

Pump capacity:

25.7 gpm @ 2350 rpm @ 2000 psi  
(97.3 l/min @ 2350 r/min @ 13 790 kPa).

18.7 gpm @ 2350 rpm @ 2000 psi  
(70.8 l/min @ 2350 r/min @ 13 790 kPa)

Control valve main

relief pressure . . . 2850 psi (19 650 kPa).

Filtration: 10-micron, full flow replaceable cartridge on return line. Condition indicator light for filter.

Backhoe control valve: Sectional four-spool valve — boom, dipper, bucket, and swing. Foot or optional hand swing. Regeneration and hydraulic cushioned swing stops.

Mono-cast two spool stabilizer valve with pilot checks.

Hydraulic lines: Steel tubing with brazed or flared fittings and wire braid, high-pressure hose with crimped, full flow fittings.

Backhoe cylinders:

Stabilizers (2) . . . . .

4.5" dia x 22.35" stroke, 2" rod

(114 mm dia x 568 mm stroke, 51 mm rod)

Swing (2) . . . . .

4" dia x 14.8" stroke, 2"

(102 mm dia x 376 mm stroke, 52 mm rod)

Boom (2) . . . . .

4" dia x 41.19" stroke, 2.25" rod

(102 mm dia x 1.05 m stroke, 57 mm rod)

Dipper (1) . . . . .

4.5" dia x 39.81" stroke, 2.5" rod

(114 mm dia x 1.01 m stroke, 64 mm rod)

Bucket (1) . . . . .

4" dia x 27.25" stroke, 2.25" rod

(102 mm dia x 692 mm stroke, 57 mm rod)

Dipper extension (1) . . . . .

3" dia x 48" stroke, 1.5" rod

(76 mm dia x 1.22 m stroke, 38 mm rod)

## Dig Depth

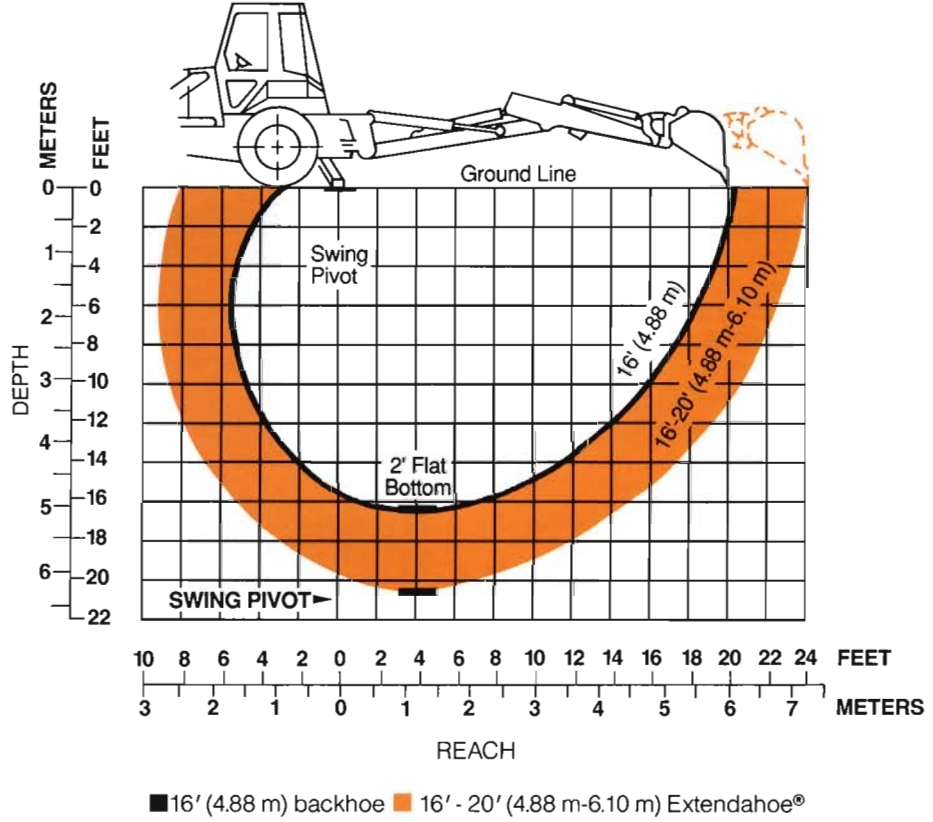

## Operational Data

### 16' (4.88 m) Backhoe

### 16'-20' (4.88 m-6.10 m) Extendahoe®

		16'-20' (4.88 m-6.10 m) Extendahoe®	
		Retracted	Extended
Digging depth—SAE, 2' (610 mm) flat bottom . . . . .	16'5" (5.00 m)	16'6" (5.03 m)	20'6" (6.25 m)
Digging depth—SAE, maximum . . . . .	16'6" (5.03 m)	16'7" (5.05 m)	20'7" (6.27 m)
Overall reach from rear axle centerline . . . . .	23'6" (7.16 m)	23'8.6" (7.23 m)	27'8.6" (8.45 m)
Digging radius from swing pivot . . . . .	19'9.6" (6.04 m)	20' (6.10 m)	24' (7.32 m)
Loading height . . . . .	11'2.6" (3.42 m)	11'7.5" (3.54 m)	13'11" (4.24 m)
Loading reach . . . . .	8'7.8" (2.64 m)	8'7.5" (2.63 m)	11'10.7" (3.63 m)
Swing arc . . . . .	188°	188°	188°
Bucket rotation# 1 position . . . . .	157°	151°	151°
#2 position . . . . .	127°	122°	122°
Stabilizer spread—operating position . . . . .	9'10" (3.0 m)	9'10" (3.0 m)	9'10" (3.0 m)
Stabilizer spread—transport position . . . . .	7'6.5" (2.43 m)	7'6.5" (2.43 m)	7'6.5" (2.43 m)
Digging force, bucket cylinder, SAE . . . . .	11,289 lbf (50 216 N)	11,812 lbf (52 542 N)	11,812 lbf (52 542 N)
Digging force, dipper cylinder, SAE . . . . .	8,642 lbf (38 442 N)	8,536 lbf (37 970 N)	6,027 lbf (26 809 N)
Leveling angle (maximum slope on which backhoe will make vertical cut)			

# 680L Backhoe

## Lift Capacity Charts—

- Lift capacity figures on this chart of 87% of the maximum lift force per SAE Definition J31 and J49 at 2550 psi (17 582 kPa) system relief pressure.
- Backhoe straight to rear lift capacity within 45° either side of prime mover.
- Backhoe within swing arc lift capacity anywhere within full swing arc.
- Figures stated are determined by static tests and do not include dynamic factors.
- Machine equipped with 24" (610 mm) trenching bucket.
- Boom is angled at 65°.

## 16' (4.88 m) BACKHOE LIFT CAPACITY

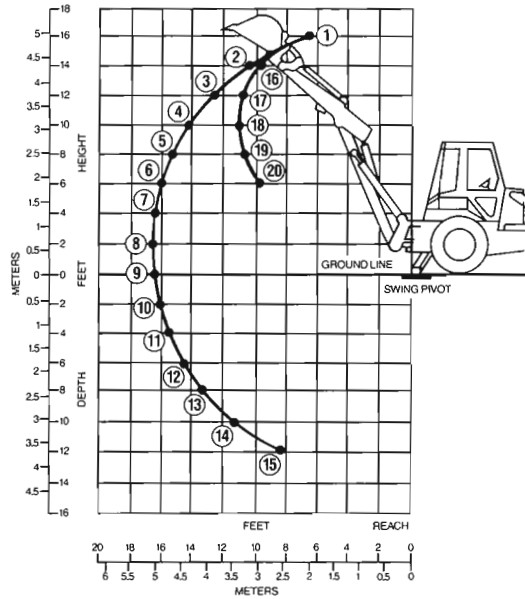

### Backhoe Straight to Rear

Pounds	(kg)	Pounds	(kg)
1.	1880 (853)	11.	3140 (1425)
2.	2680(1216)	12.	3025 (1372)
3.	3150(1429)	13.	3090 (1402)
4.	3260(1479)	14.	3220 (1461)
5.	3260(1479)	15.	3530 (1601)
6.	3340(1515)	16.	5105 (2316)
7.	3360(1524)	17.	5220 (2368)
8.	3425(1554)	18.	5125 (2325)
9.	3390(1538)	19.	5480 (2486)
10.	3330(1511)	20.	6350 (2880)

### Backhoe Within Swing Arc

Pounds	(kg)	Pounds	(kg)
1.	940 (426)	11.	3140 (1425)
2.	2680(1216)	12.	3025 (1372)
3.	3025(1372)	13.	3090 (1402)
4.	3260(1479)	14.	3220 (1461)
5.	3260(1479)	15.	3530 (1601)
6.	3340(1515)	*16.	4985 (2261)
7.	3360(1524)	*17.	4750 (2155)
8.	3425(1554)	*18.	4785 (2170)
9.	3390(1538)	*19.	4995 (2266)
10.	3330(1511)	*20.	5775 (2620)

## EXTENDAHOE LIFT CAPACITY (DIPPER EXTENDED)

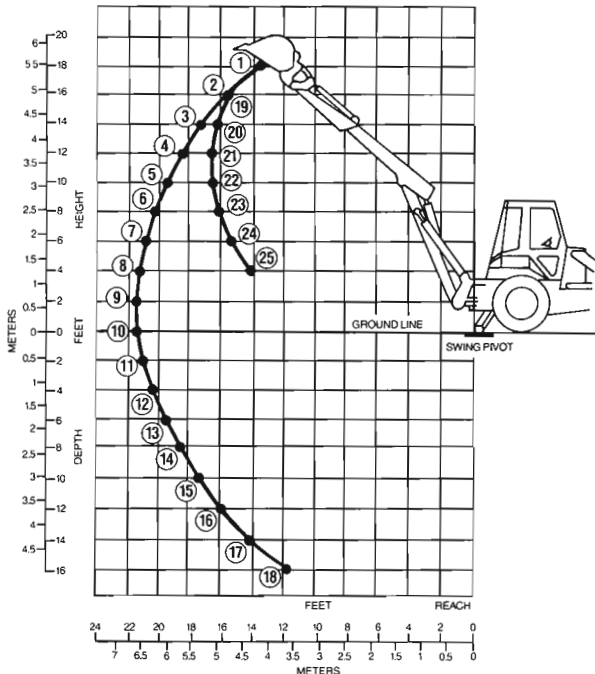

## EXTENDAHOE LIFT CAPACITY (DIPPER RETRACTED)

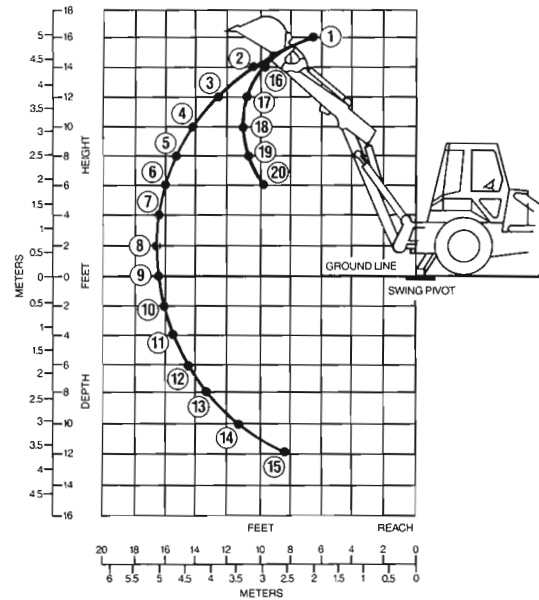

### Backhoe Straight to Rear

Pounds	(kg)	Pounds	(kg)
1.	1460 (662)	14.	1710 (776)
2.	1650 (748)	15.	1730 (785)
3.	1800 (816)	16.	1810 (821)
4.	1860 (844)	17.	1880 (853)
5.	1880 (853)	18.	1975 (896)
6.	1860 (844)	19.	2875 (1304)
7.	1880 (853)	20.	3045 (1381)
8.	1860 (844)	21.	3095 (1404)
9.	1860 (844)	22.	3025 (1372)
10.	1880 (853)	23.	3125 (1418)
11.	1810 (821)	24.	3135 (1422)
12.	1740 (789)	25.	3235 (1467)
13.	1720 (780)		

### Backhoe Within Swing Arc

Pounds	(kg)	Pounds	(kg)
1.	1330(603)	14.	1710 (776)
2.	*1650(748)	15.	1730 (785)
3.	1800(816)	16.	1810 (821)
4.	1860(844)	17.	1880 (853)
5.	1880(853)	18.	1975 (896)
6.	1860(844)	*19.	2825 (1281)
7.	1880(853)	*20.	2675 (1213)
8.	1860(844)	*21.	2545 (1154)
9.	1860(844)	*22.	2465 (1118)
10.	1880(853)	*23.	2330 (1057)
11.	1810(821)	*24.	2760 (1252)
12.	1740(789)	*25.	3110 (1411)
13.	1720(780)		

### Backhoe Straight to Rear

Pounds	(kg)	Pounds	(kg)
1.	1890 (857)	12.	2260 (1025)
2.	2655 (1222)	13.	2250 (1021)
3.	2740 (1243)	14.	2280 (1034)
4.	2705 (1227)	15.	2375 (1077)
5.	2680 (1220)	16.	5290 (2400)
6.	2625 (1191)	17.	4770 (2164)
7.	2580 (1170)	18.	4595 (2084)
8.	2565 (1163)	19.	4705 (2134)
9.	2490 (1129)	20.	5605 (2542)
10.	2400 (1089)		
11.	2400 (1089)		

### Backhoe Within Swing Arc

Pounds	(kg)	Pounds	(kg)
1.	1890 (857)	12.	2260 (1025)
2.	2615 (1186)	13.	2250 (1021)
3.	2675 (1213)	14.	2280 (1034)
4.	2705 (1227)	15.	2375 (1077)
5.	2680 (1220)	*16.	4535 (2057)
6.	2625 (1191)	*17.	4135 (1876)
7.	2580 (1170)	*18.	3995 (1812)
8.	2565 (1163)	*19.	4265 (1935)
9.	2490 (1129)	*20.	5075 (2302)
10.	2400 (1089)		
11.	2400 (1089)		

# Dimensional Data

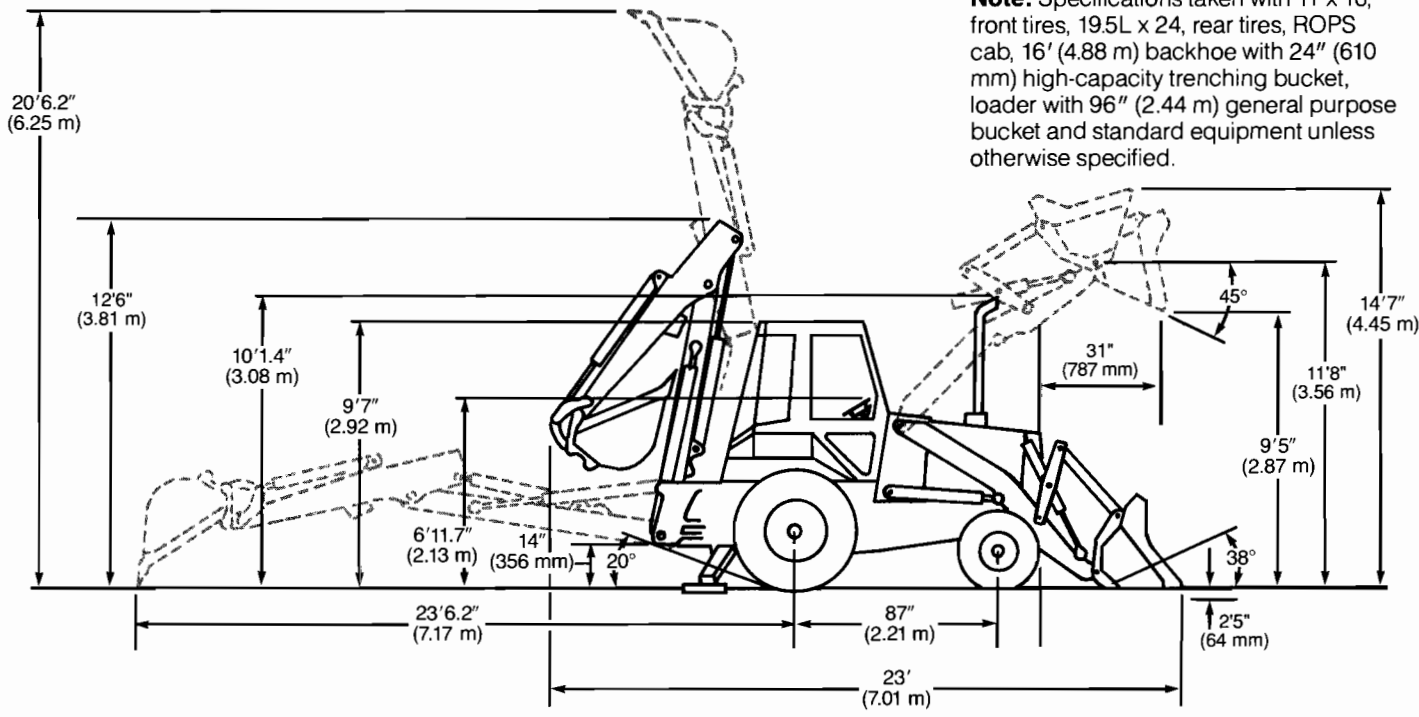

**Note:** Specifications taken with 11 x 16, front tires, 19.5L x 24, rear tires, ROPS cab, 16' (4.88 m) backhoe with 24" (610 mm) high-capacity trenching bucket, loader with 96" (2.44 m) general purpose bucket and standard equipment unless otherwise specified.

### Tractor

Overall width	.8' (2.44 m)
Height: to top of canopy	9'7" (2.92 m)
Height: to top of cab	9'7" (2.92 m)
Height: to top of exhaust stack	10'1.4" (3.08 m)
Height to top of steering wheel	6'11.7" (2.13 m)
Front wheel tread	6'6.5" (1.99 m)
Rear wheel tread	5'11.5" (1.82 m)
Wheel base	.87" (2.21 m)

### Tractor/Loader/Backhoe

	Backhoe 16' (4.88 m)	Extendahoe® Retracted	Extended
Overall length—transport			
1.5 yd <sup>3</sup> (1.15 m <sup>3</sup> ) G.P. bucket	23' (7.01 m)	23'7" (7.19 m)	N.A.
1.75 yd <sup>3</sup> (1.34 m <sup>3</sup> ) G.P. bucket	23' (7.01 m)	23'7" (7.19 m)	N.A.
1.25 yd <sup>3</sup> (0.97 m <sup>3</sup> ) 4-in-1 bucket	23'2" (7.06 m)	23'9" (7.24 m)	N.A.
1.5 yd <sup>3</sup> (1.15 m <sup>3</sup> ) 4-in-1 bucket	23'2" (7.06 m)	23'9" (7.24 m)	N.A.
Overall reach from rear axle centerline	23'6" (7.16 m)	23'8.6" (7.23 m)	27'8.6" (8.95 m)
swing pivot	19'9.6" (6.04 m)	20' (6.10 m)	24' (7.32 m)
Overall height, maximum	20'6.2" (6.25 m)	20'8.8" (6.32 m)	24'6.6" (7.48 m)
Transport height	12'6" (3.81 m)	12'10.5" (3.92 m)	N.A.
Overall width—transport	96" (2.44 m)	96" (2.44 m)	96" (2.44 m)
Ground clearance at backhoe main frame	14" (356 mm)	14" (356 mm)	14" (356 mm)
Angle of departure	20°	20°	20°

### Tractor/Loader

	General Purpose Buckets		High Density 4-in-1® Bucket	Low Density 4-in-1® Bucket
	1.5 yd <sup>3</sup> (1.15 m <sup>3</sup> )	1.75 yd <sup>3</sup> (1.34 m <sup>3</sup> )	1.25 yd <sup>3</sup> (0.97 m <sup>3</sup> )	1.5 yd <sup>3</sup> (1.15 m <sup>3</sup> )
Overall width	96" (2.44 m)	96" (2.44 m)	96" (2.44 m)	96" (2.44 m)
Overall operating height, maximum	14'7" (4.45 m)	14'11.5" (4.56 m)	14'7" (4.46 m)	14'7" (4.46 m)
Digging depth below ground—bucket flat	2.5" (64 mm)	2.5" (64 mm)	10" (254 mm)	10" (254 mm)
Height to bucket hinge pin	11'8" (3.56 m)	11'8" (3.56 m)	11'3.5" (3.44 m)	11'3.5" (3.44 m)
Dump angle at full height	45°	45°	45°	45°
Dump clearance at full height 45° dump	9'5" (2.87 m)	9'5" (2.87 m)	9'1" (2.77 m)	9'4" (2.85 m)
Dump reach at full height 45° dump	31" (787 mm)	31" (787 mm)	38" (965 mm)	37.5" (953 mm)
Bucket rollback at ground line	38°	38°	40°	40°

# Equipment Attachments

## Standard Equipment

### Tractor

Air cleaner, dry type with replaceable cartridge  
• Alternator and regulator • Anti-freeze solution to -20°F (-29°C) • Axle (front), heavy-duty with 78.5" (1.99 m) fixed tread • Brakes, wet disc • Brake, parking • Electrical system, 12-volt • Engine, 90 hp (67 kW) Case 6-590 diesel • Fenders, rear • Floor plates • Gauges and Instruments: air cleaner restriction light, alternator charge warning light, clutch pressure light, condition light for loader and backhoe hydraulic system filter, converter temperature gauge, engine oil gauge, engine water temperature gauge, fuel level gauge, hourmeter, parking brake light, tachometer • Halogen headlights, one rear working and one red tail • Instrument cluster, illuminated • Muffler, upright with deflector • Oil cooler, hydraulic • Oil filter, full flow • Transmission, 3-speed powershift • Radiator opening, lockable • ROPS canopy on isolated operator's compartment • Safety belt, seat mounted, • Seat, Easy Ride with single lever turnaround adjustment • Side panels, full length of engine • Steering, hydrostatic • Throttle, hand and foot • Tires (front) 14.5/75 x 16.1, 10PR • Tires (rear) 21L x 24, 12PR, R4 • Toolbox • Wrapper, front

### Loader

All tractor standard equipment • Anti-rollback • Control, single lever • Hydraulic system, complete • Indicator, bucket level • Loader (less bucket) • Return-to-dig • Self-leveling • Support strut, lift arm

### 16' (4.88 m) Backhoe

All tractor and loader standard equipment • Hydraulic system, complete, including three-lever, footswing control • Over-center backhoe (less bucket) • Stabilizers with two-position cleated pads

### 16' -20' (4.88 m-6.10 m) Extendahoe

All tractor, loader and backhoe equipment • Hydraulic telescoping Extendahoe, accessory hydraulics

## Optional Equipment

### Tractor

Air conditioning • Alarm, backup • Antifreeze to -40°F (-40°C) • Beacon, rotating • Full lockup package • Horn • Lights, combination tail, stop, directional and flasher with rear flood light • Muffler, spark arresting • Paint, special • ROPS cab with air filtration, defogger, heater pressurization and floor mat • Front and rear wipers, lights, working, directional, flashers • Seat, deluxe suspension • Start kit, cold weather • Tires various sizes — see tractor section • 4-wheel drive

### Loader

All tractor optional equipment • Accessory hydraulics • Bucket teeth • Two capacity sizes of 96" (2.44 m) general purpose buckets • 96" (2.44 m) 4-in-1 bucket

### Backhoe

All tractor and loader optional equipment • Dual lever backhoe controls • Street-cemetery stabilizer pads • 12" (305 mm) and 18" (457 mm) standard-duty trenching buckets • 24" (610 mm), 30" (762 mm) and 36" (914 mm) high capacity trenching buckets • 24" (610 mm) and 30" (762 mm) heavy-duty trenching buckets

## Approximate Shipping Weights

**Note:** Specifications taken with 11.00 x 16 front tires, 19.5L x 24 rear tires, ROPS canopy and standard equipment unless otherwise specified.

### Tractor/Loader/Backhoe (Less Buckets)

16' (4.88 m) backhoe with ROPS canopy  
2-wheel drive . . . . . 17,218 lbs (7810 kg)  
4-wheel drive . . . . . 17,922 lbs (8129 kg)  
16' (4.88 m) backhoe with ROPS cab  
2-wheel drive . . . . . 17,704 lbs (8030 kg)  
4-wheel drive . . . . . 18,408 lbs (8350 kg)  
16' -20' (4.88 m—6.10 m) Extendahoe w/ROPS canopy  
2-wheel drive . . . . . 18,208 lbs (8259 kg)  
4-wheel drive . . . . . 18,912 lbs (8578 kg)  
16' -20' (4.88 m—6.10 m) Extendahoe w/ROPS cab  
2-wheel drive . . . . . 18,694 lbs (8479 kg)  
4-wheel drive . . . . . 19,398 lbs (8799 kg)  
Counterweight . . . . . Add 600 lbs (272 kg)  
Note: Extendahoe unit requires 4-in-1 bucket or 600 lb (272 kg) counterweight.  
Air conditioning . . . . . Add 30 lbs (14 kg)

### Loader Buckets (Optional)

96" (2.44 m)  
general purpose . . . . . 809 lbs (367 kg)  
96" (2.44 m)  
light material . . . . . 1034 lbs (469 kg)  
96" (2.44 m) 4-in-1  
high density . . . . . 2250 lbs (1021 kg)  
96" (2.44 m) 4-in-1  
low density . . . . . 2410 lbs (1093 kg)

### Backhoe Buckets (Optional)

#### Standard Trenching

\* 12" (305 mm) . . . . . 205 lbs (93 kg)  
18" (457 mm) . . . . . 260 lbs (118 kg)

#### Hi-capacity Trenching

24" (610 mm) . . . . . 405 lbs (184 kg)  
30" (762 mm) . . . . . 467 lbs (212 kg)  
36" (914 mm) . . . . . 505 lbs (229 kg)

#### Heavy-duty Trenching

24" (610 mm) . . . . . 475 lbs (216 kg)  
30" (762 mm) . . . . . 525 lbs (238 kg)  
\*for 16' (4.88 m) backhoe only.



Extendahoe, 4-in-1, and Construction King are trademarks of the J I Case Company.

**NOTE:** All specifications are stated in accordance with SAE Standards or Recommended Practices, where applicable.

**IMPORTANT**

J I Case Company reserves the right to change these specifications without notice and without incurring any obligation relating to such change. Unit illustrated may be equipped with non-standard items.

**Sold and Serviced by:**