



ENGINE

Model	F5C E5454 C* A003
Emissions Certification	Non-regulated/Tier 3
Type	Diesel, Turbo – Direct Injection
Cylinders	4
Bore/Stroke	3.9 x 4.1 in (99 x 104 mm)
Displacement	195 in ³ (3.2 L)
Fuel injection	Direct
Fuel	#2 Diesel
Fuel filter	In-line strainer
Oil filtration	Spin-on/full-flow
Air intake	Turbocharged w/o waste gate
Cooling	Liquid
Engine speeds	RPM
High idle – no load	2675 +/- 75
Rated – full load	2500
Low idle	1075 +/- 75
Horsepower @ 2500 RPM – SAE J1349:	
Gross	90 hp (67 kW)
Net	84 hp (63 kW)
Peak torque @ 1400 RPM	251 lb-ft (340 N-m)
Radiator:	
Core type	All aluminum
Core size area	412 in ² (0.266 m ²)
Rows of tubes x columns	44 x 4
Cap pressure	16 +/- 2 psi (1.10 +/- 0.14 bar)
Fan:	
Diameter	20.4 in (518 mm)
Ratio	0.96:1
Water pump:	
Style	Centrifugal
Flow	29 gpm (110 L/min)
Engine lubrication pump:	
Rotor pump w/ deep sump pan, plate cooler and pressurized under-piston nozzles	
Pump operating angle ratings:	
Side to side	45°
Bucket up	35°
Bucket Down	45°

DRIVETRAIN

Drive pump controls	Electro-hydraulic
Pump to engine ratio	1:1
Displacement	2.81 in ³ (46 cm ³)
Flow @ rated engine RPM:	
@ 97% efficiency	29.4 gpm (111 L/min)
Charge pressure	
360+/- 18 psi (24.5 +/- 0.5 bar)	
System relief pressure	5,220 psi (261 bar)
Drive motors:	
Max. displacement	2.75 in ³ (45 cm ³)
Optional high speed	34.6 in ³ (131 cm ³)
Speed @ high idle engine RPM	
100% efficiency @ rated engine RPM	103
Speed @ optional high speed RPM	156
Torque @ max. displacement and relief pressure -calculated, 5,003 psi (345 bar):	4,654 lb-ft (6 310 N-m)
Travel speed:	
Low range	5.1 mph (8.2 kph)
High range – optional	7.6 mph (12.2 kph)
Final drive	Planetary reduction
Parking brake:	
Type	Spring-applied, hydraulic release disc
Engagement	Depress on/off brake button on handle or instrument panel, raise seat bar, get off seat or stop engine

ELECTRICAL

Alternator	120 amp
Starter	4.29 hp (3.2 kW)
Battery	12-volt low-maintenance 925 cold-cranking amps @ 0° F (-18° C°)

OPERATOR ENVIRONMENT

Enclosed Cab w/ Heater and AC; Fully sealed and pressurized – FSP; Glass door w/ wiper and washer; Sliding side windows – removable; Heater and air conditioner; AM/FM radio w/ 2 speakers; Keyless start ignition; Tilt ROPS/FOPS; Rear window w/ emergency escape; Deluxe cloth, air suspension seat, w/ 2 in (51 mm) retractable 3 point lap seat belt w/ heater and lumbar support; Hand and foot throttles; Alarm package – back-up and horn; Headliner; Dome Light; Top window; Cup holder; 12V Power plug socket; Foot rest; Seat pocket; Padded seat bar w/ integral armrests; Loader control lockout system; Electric parking brake control; Operator's compartment floor cleanout; Proportional auxiliary hydraulic control – on joystick; Advanced Instrument Cluster w/ digital hour meter, tachometer, Fuel level LCD bar graph w/ alarm, diagnostic features and security lockout.

Warning lights with alarms:
Engine coolant temperature; Engine oil pressure; Engine malfunction; Hydraulic charge pressure; Hydraulic filter restriction; Hydraulic oil temperature; Critical system stop, Engine system, Hydraulic system, Electrical and diagnostic system.

Warning alarms:
Battery voltage – plus display; Oil service

Indicator light:
Engine preheat; Parking brake;
Seat bar reminder.

OPERATING WEIGHT

Operating weight	9,600 lb (4 355 kg)
Shipping weight	9,265 lb (4 200 kg)
Add-on weights:	
Side cab glass	47 lb (21.3 kg)
Lexan® door	74 lb (33.6 kg)
Glass door w/ wiper	134 lb (60.8 kg)
Suspension seat	22 lb (10.0 kg)

HYDRAULICS

Standard equipment pump type	Gear
Displacement:	
Standard aux.	2.08 in ³ (34.1 cm ³)
High-flow aux.	1.1 in ³ (18.3 cm ³)
Pump flow @ rated engine RPM:	
@ 100% efficiency	22.5 gpm (85 L/min)
Optional high flow @ rated engine RPM:	
@ 100% efficiency	12.1 gpm (46 L/min)
Loader control valve:	
Type	3 spool/Open center/Series
Relief pressure	3,000 (+145/-0) psi (207 bar)
Port relief pressures:	
Loader raise	3,263 psi (225 bar)
Bucket dump	3,770 psi (260 bar)
Bucket curl	1,160 psi (80 bar)
Hydraulic lines:	
Tubing	37° JIC Flare
Loop hoses	SAE 100 R13

Hydraulic oil cooler:	
Number of fins	10 per inch (3.94 per cm)
Number of tubes	11
Area	130.7 in ² (843 cm ²)
Hydraulic filter	6 micron/Spin-on

Lift cylinders:	
Bore diameter	2.75 in (69.85 mm)
Rod diameter	1.75 in (44.5 mm)
Stroke	32.2 in (817.9 mm)
Closed length	45.6 in (1 158.0 mm)

Bucket cylinders:	
Bore diameter	3.0 in (76.2 mm)
Rod diameter	1.5 in (38.1 mm)
Stroke	16.14 in (410.0 mm)
Closed length	24.0 in (610.0 mm)

SERVICE CAPACITIES

Fuel Tank	25.5 gal (96.5 L)
Engine oil w/ filter	10.0 qt (9.4 L)
Hydraulic system:	
Reservoir	7 gal (26.5 L)
Total	11.75 gal (44.5 L)

PERFORMANCE SPECS

Rated operating load:	
35% of tipping load	2,240 lb (1 018 kg)
50% of tipping load	3,200 lb (1 451 kg)
Tipping load	6,400 lb (2 902 kg)
Breakout forces – calculated @ 3,150 psi:	
Bucket cylinder-tip	8,700 lb (38.7 kN)
Lift cylinders	7,760 lb (34.5 kN)
Cycle times:	
Raise	4.5 sec
Lower	2.7 sec
Dump	2.7 sec
Roll back	2.0 sec

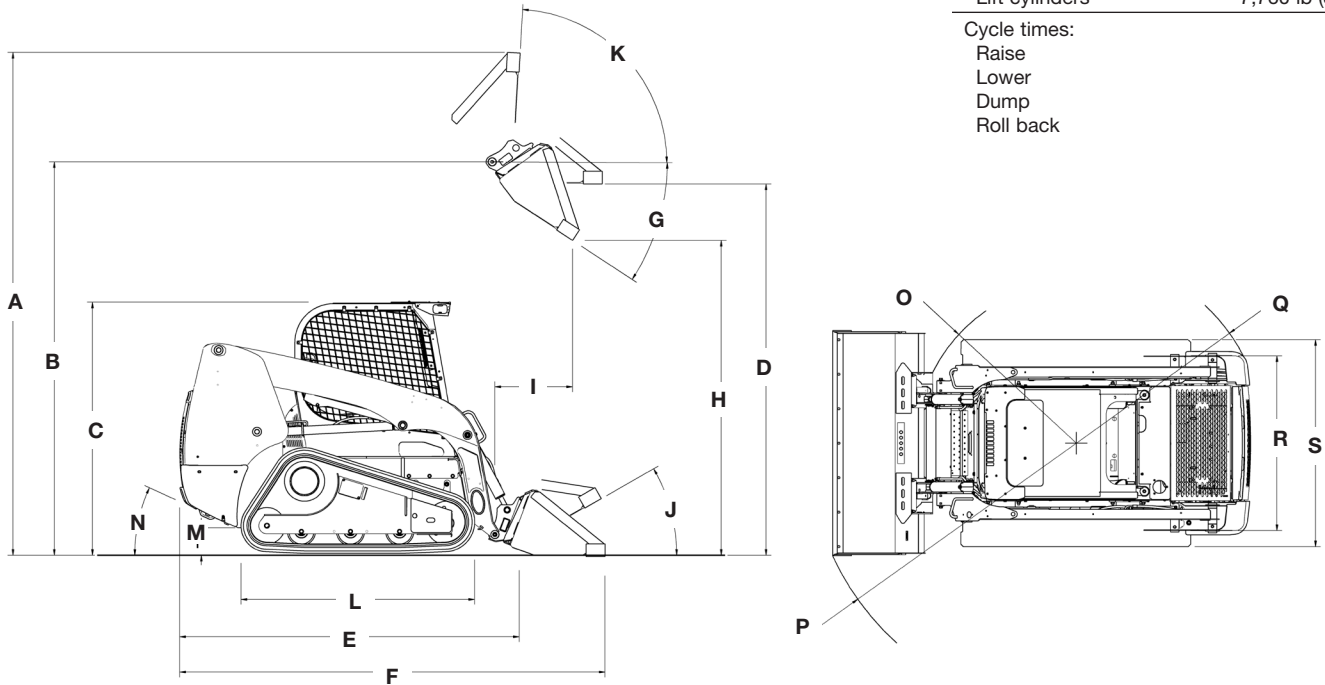

Line drawings are for illustrative purpose only and may not be exact representation of unit.

DIMENSIONS

A. Overall operating height:	
with foundry/excavating bucket short lip	157.8 in (4.01 m)
with low profile/standard lip bucket	161.8 in (4.11 m)
with low profile extended/long lip bucket	166.8 in (4.24 m)
Height to:	
B. Bucket hinge pin	126.5 in (3.22 m)
C. Top of ROPS	80.4 in (2.04 m)
D. Bottom of level bucket, fully raised	119.6 in (3.04 m)
Overall length:	
E. without attachment with coupler	117.4 in (2.98 m)
F. with foundry/excavating bucket on ground	142.2 in (3.61 m)
with low profile bucket	146.2 in (3.71 m)
with low profile extended bucket	151.3 in (3.84 m)
G. Dump angle	38.1°
H. Dump height:	
with foundry/excavating bucket short lip	102.4 in (2.60 m)
with low profile/standard lip bucket	99.9 in (2.54 m)
I. Dump reach – max. height	21.6 in (0.55 m)
Maximum attachment rollback:	
J. Bucket on ground	29.7°
K. Bucket at full height	99.7°
L. Track on ground	64.5 in (1.60 m)
M. Ground clearance – bottom of belly pan	9.5 in (0.24 m)
N. Angle of departure	32.0°
Clearance circle:	
O. without bucket	55.1 in (1.40 m)
P. with 78 in (2.0 m) foundry/excavating bucket in carry position	85.5 in (2.17 m)
with 78 in (2.0 m) low profile bucket on ground	88.7 in (2.25 m)
with 78 in (2.0 m) extended low profile on ground	93.0 in (2.36 m)
Q. Clearance circle rear	70.4 in (1.79 m)
R. Track width	58.3 in (1.48 m)
S. Over the track width	76.0 in (1.93 m)

TRACK SELECTION

Type	Area	Ground Pressure	Width to Outside of Track
15.7 in (400 mm)	2,038 in ² (13 120 cm ²)	4.2 psi (29 kPa)	74 in (1.88 m)
17.7 in (450 mm)	2,293 in ² (13 776 cm ²)	4.3 psi (29.7 kPa)	76 in (1.93 m)

OPTIONAL BUCKETS

Type	Width	Weight	Heaped Capacity
Dirt & Foundry	78 in (1.98 m)	440 lb (200 kg)	17.7 ft ³ (0.50 m ³)
Low Profile Extended	78 in (1.98 m)	540 lb (245 kg)	19.1 ft ³ (0.54 m ³)
	84 in (2.13 m)	607 lb (275 kg)	20.2 ft ³ (0.57 m ³)
Light Material	84 in (2.13 m)	540 lb (245 kg)	27.5 ft ³ (0.78 m ³)
Manure & Slurry	84 in (2.13 m)	545 lb (248 kg)	22.6 ft ³ (0.64 m ³)
Heavy-Duty	78 in (1.98 m)	530 lb (240 kg)	15.5 ft ³ (0.44 m ³)
	84 in (2.13 m)	758 lb (344 kg)	25.7 ft ³ (0.47 m ³)

STANDARD EQUIPMENT

OPERATOR ENVIRONMENT

See page 1

ENGINE

F5C E5454 C*A003
195 CID (3.2 L) Turbo
Non-regulated
Tier 3
Turbocharged without waste gate
fuel injection
Horsepower:
Gross: 90 hp (67 kW)
Net: 84 hp (63 kW)
Peak torque 251 lb-ft (340 N·m)
120 amp alternator
Dual element air cleaner
Organic Acid Technology (OAT)
Anti-freeze solution to -34° F
Fuel tank - 25.5 gal (U.S.)
Over and under radiator and oil cooler
3-stack after cooler/radiator/oil
cooler configuration
Glow plugs
Integral engine oil cooler
Fuel filter with water trap
1,000 CCA 12V battery
Master electrical disconnect

DRIVETRAIN

2-speed hydrostatic four wheel drive
SAHR disc parking brake

HYDRAULICS

Auxiliary hydraulics:
@ 3,050 psi (210 bar) – 23.8 gpm
(90.0 L/min)
6 micron oil filtration system
3-spool loader control valve
Auxiliary hydraulic disconnects, ISO
flat-face – connect-under-pressure
with case drain
Hydraulic circuit pedal lock
Auxiliary function lockout override
Loader lift lockout override
Heavy-duty hydraulic oil cooler
Loader arm float position
Loader function lockout system
Hydraulic one-way self-leveling
Ride control

LOADER

Heavy duty hydraulic attachment coupler
Radial lift geometry
Loader lift arm support strut
SAE operating load: 3,400 lbs
Tipping load: 6,800 lbs

TRACKS

HiQual S-Wave Tracks

OTHER STANDARD FEATURES

Halogen lights - 2 front, 2 side, 2 rear flood
Heavy duty front lights
Pre-wired for rotating beacon
Lockable service access hood
Single-point daily servicing
Rear tail lights
Remote oil drain
Remote oil and fuel filters
Block heater
Debris ingress sealing
Machine protection auto shutdown
Mounting points for add-on counterweights

OPTIONAL EQUIPMENT

OPERATOR ENVIRONMENT

ROPS/FOPS Level 1 canopy with side screens
Keyed start ignition
Ventilation system with integrated heater
Electro-hydraulic controls:
 For drive/steering, loader functions
 Switchable between H and ISO patterns
 Adjustable sensitivity of controls
Mechanical hand controls
Hand and foot controls:
 Hand controls the loader drive function
 and foot controls the bucket and boom
Non suspension seat
Suspension seat, vinyl
Open cab interior trim package
Demolition cab door with polycarbonate
FOPS level 2
Heavy duty rear door

HYDRAULICS

High-flow auxiliary hydraulics – combined:
 @ 3,050 psi (210 bar) – 33.2 gpm
 (126 L/min)
Enhanced High-flow auxiliary hydraulics – EHF:
 @ 4,000 psi (276 bar) – 35.0 gpm
 (132.5 L/min)
Second auxiliary hydraulics

LOADER

Auxiliary front electric control
Manual attachment coupler

OTHER

Language decals
Factory-installed tires – see page 3
Buckets – see page 3
Bolt-on bucket cutting edges
Bolt-on heavy-duty bucket spill guard
Special paint
Offsite service arrangement
Telematics

FACTORY SUPPLIED ATTACHMENTS

Interior mirror
Add-on counterweights
Road lights
Rotating beacon
Four-corner LED strobe
Bolt-on heavy-duty bucket teeth
48 in (1.22 m) pallet forks

SERVICE PARTS

3 inch (76.2 mm) retractable seat belt

CaseCE.com

©2016 CNH Industrial America LLC. All rights reserved. CASE is a trademark registered in the United States and many other countries, owned by or licensed to CNH Industrial N.V., its subsidiaries or affiliates. CNH Industrial Capital is a trademark in the United States and many other countries, owned by or licensed to CNH Industrial N.V., its subsidiaries or affiliates. Printed in U.S.A. Contains 10% post-consumer fiber.

IMPORTANT: CASE Construction Equipment Inc. reserves the right to change these specifications without notice and without incurring any obligation relating to such change. Availability of some models and equipment builds vary according to the country in which the equipment is used. The illustrations and text may include optional equipment and accessories and may not include all standard equipment. Your CASE dealer/distributor will be able to give you details of the products and their specifications available in your area.



CASE Construction Equipment is biodiesel-friendly. NOTE: All engines meet current EPA emissions regulations. All specifications are stated in accordance with SAE Standards or Recommended Practices, where applicable.



Always read the Operator's Manual before operating any equipment. Inspect equipment before using it, and be sure it is operating properly. Follow the product safety signs and use any safety features provided.

Form No. CCE201604TR320T3
Replaces Form No. CCE201511TR320T3

TR320

4 of 4