

ENGINE

Make	Deutz
Type	D2011 L3 Tier 4 Interim Certified
Rated horsepower	48 hp (36 kW)
Fuel consumption	0.9 gal/hr (3.5 L/hr)

ELECTRICAL

Voltage	12 volts
Batteries	1 x 12 volt
Battery reserve capacity	74 Ah/5 hour
Cold cranking amps	640 CCA

STEERING

Pump type	Gear
Cylinders	1
Steering angle (left & right)	33°
Oscillation angle	10°
Inner turning radius	99.6 in (2.53 m)
Relief pressure	2537 PSI (17.5 MPA)

WEIGHT

Operating weight	7,720 lbs (3500 kg)
Front drum weight	3,860 lbs (1750 kg)
Rear drum weight	3,860 lbs (1750 kg)
Front drum linear load	75 lb/in (13.5 kg/cm)
Rear drum linear load	75 lb/in (13.5 kg/cm)

TRAVEL

Drive	Hydrostatic
Variable displacement axial piston type drum drive pump	1
Hydraulic fixed displacement drum drive motors	2
Service brake	Hydrostatic
Parking/emergency brake	SAHR
Maximum relief pressure	5075 PSI (35 MPA)
Maximum working speed	4.7 mph (7.5 km/h)
Maximum travel speed	6.2 mph (10 km/h)
Gradeability (vibration off)	40° (20°)

VIBRATION

System design	Closed center
Pump type	Gear
Fixed displacement hydraulic motor	2
Maximum relief pressure	3480 PSI (24 MPA)
Vibration	Eccentric
Frequency —	
Low	3180 vpm (53 Hz)
High	3720 vpm (62 Hz)
Rated amplitude	0.0177 in (0.45 mm)
Centrifugal force —	
Low	6,476 lbs (29.4 kN)
High	8,877 lbs (40.3 kN)
Dynamic linear load —	
Low	127 lbs/in (0.02 kN/mm)
High	173 lbs/in (0.03 kN/mm)
Watering system	Pressurized
Front tank capacity	17.7 gal (67 L)
Rear tank capacity	42.3 gal (160 L)
Tank type	Polyethylene

CAPACITIES

Fuel tank	18.5 gal (70 L)
Engine oil	1.7 gal (6.5 L)
Hydraulic reservoir	10 gal (38 L)
Vibration system (each)	0.48 gal (1.8 L)

OPERATORS COMPARTMENT

Insulated from chassis by flexible shock absorbers, handrail, instrument panel anti-vandal guard, exceptional front/rear visibility, ROPS protection, single lever speed and direction control with vibration on/off control.

MAXIMUM COMPACTED LIFT THICKNESS

Sand/gravel	11.8 in (300 mm)
Mixed soils	7.9 in (200 mm)
Asphalt	4.7 in (120 mm)

STANDARD EQUIPMENT

- Fixed ROPS
- Anti-vandal guard
- Hydrostatic drive for both drums
- Dual vibration
- Front/dual drum vibration control
- Auto vibration stop in neutral
- Articulated chassis
- Hydraulic oil cooler
- Backup alarm
- 2 in (51 mm) retractable seat belt
- Lateral shifting suspension seat with foldable arms
- Pressurized water system
- Machined tapered edge drums
- Vulcollon scrapers, adjustable
- 2-stage water filtration
- Master disconnect switch
- Horn
- Hourmeter
- Emergency stop button
- 4-point lift and tie down provision
- Watering system drains
- Electric fuse protection
- Steering wheel spinner knob
- Spin-on fuel, engine oil and hydraulic filters
- Tool box
- Flip open hood
- Indicator lights
 - Battery
 - Engine oil pressure
 - Intake preheater
 - Engine temperature
 - Parking brake
 - Vibration ON/OFF
 - Sprinkler system ON/OFF

OPTIONAL EQUIPMENT

- Rotating beacon
- Halogen work lights
- Foldable ROPS
- 3 in (76 mm) retractable seat belt
- Sunshade for fixed ROPS
- Brake release

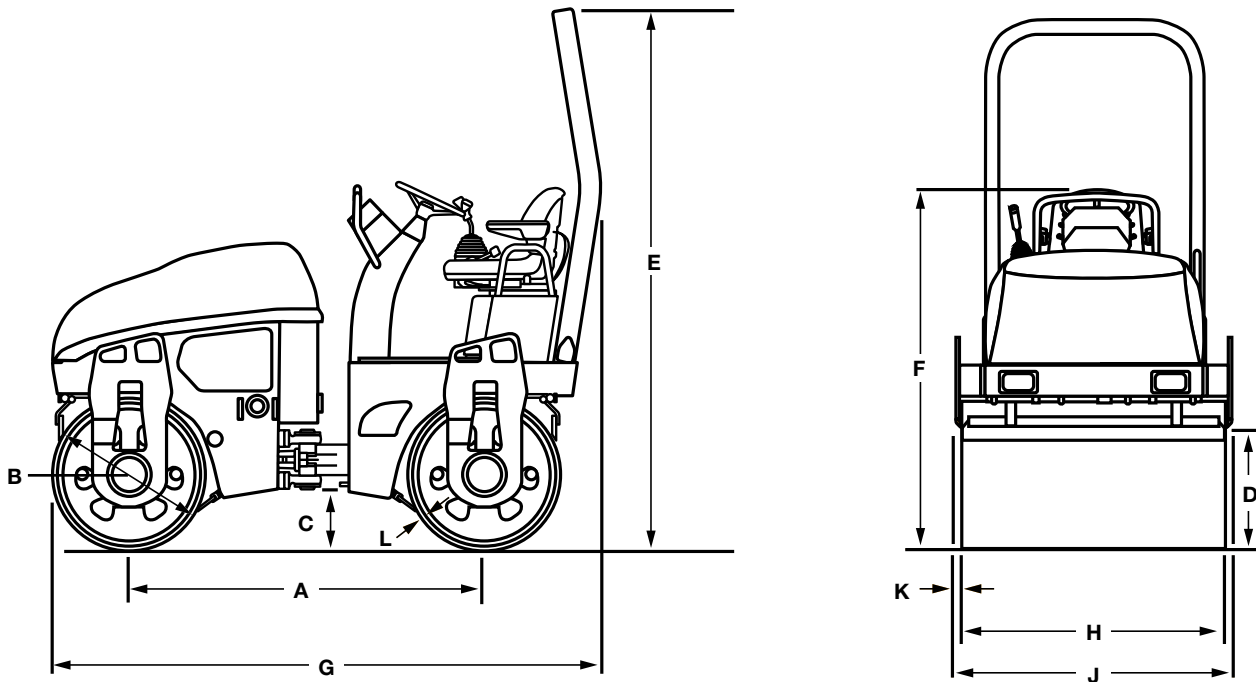

DIMENSIONS

A. Wheelbase	67.6 in (1716 mm)
B. Drum diameter	29.4 in (746 mm)
C. Ground clearance	12 in (310 mm)
D. Curb clearance	23 in (590 mm)
E. Overall height	105 in (2680 mm)
F. Folded ROPS height	72 in (1825 mm)
G. Overall length	104 in (2640 mm)
H. Drum width	51.2 in (1300 mm)
J. Overall width	54.9 in (1396 mm)
K. Frame extensions	1.8 in (45 mm)
L. Drum thickness	0.6 in (16 mm)



NOTE: All specifications are stated in accordance with SAE Standards or Recommended Practices, where applicable.

NOTE: All engines meet current EPA emissions requirements.

IMPORTANT: Case Construction Equipment Inc. reserves the right to change these specifications without notice and without incurring any obligation relating to such change. Case Construction Equipment Inc. does not warrant the safety or reliability of attachments from other manufacturers.

Case is a registered trademark of CNH America LLC. Any trademarks referred to herein, in association with goods and/or services of companies other than CNH America LLC, are the property of those respective companies.



www.casece.com