

### ENGINE

Model	Isuzu 4HK1X, Tier III certified
Type	4-stroke, turbocharged
Cylinders	4
Bore/Stroke	4.53 in x 4.92 in (115 x 125 mm)
Displacement	317 in <sup>3</sup> (5.2 L)
Fuel injection	Direct
Fule injection pump	Electronic
Fuel	Diesel
Cooling	Liquid
Horsepower per SAE J1349	
Net	157 hp (117 kW) @ 1800 rpm
Maximum torque @ 1500 rpm	
Net	463 lb-ft (628 N·m)

### BOOM/ARM

<b>Boom</b>	
Length	28 ft 7 in (8.70 m)
Boom w/arm cylinder & plumbing	5,015 lb (2275 kg)
Hoist cylinders (2)	373 lb (169 kg) ea
Total weight	5,761 lb (2613 kg)

#### 21 ft 0 in Arm (6.40 m)

Bare arm	2,992 lb (1357 kg)
Bucket cylinder linkage & plumbing	608 lb (276 kg)
Total arm weight	3,600 lb (1633 kg)

### UNDERCARRIAGE

Number of top rollers	
Top, each track	2
Bottom, each track	8
Number of shoes	
Triple grouser – each track	49
Link pitch	7.48 in (190 mm)
Gradability	70%

### HYDRAULICS

Pumps (2)	Variable displacement axial piston design
Capacity –	
Maximum	2 x 55.7 gpm (211 L/min)
System relief pressure –	
Standard	4,975 psi (34.3 MPa)
Power Boost	5,337 psi (36.8 MPa)
Control valves –	
4-spool section for right track travel, bucket, boom and arm acceleration	
5-spool section for left track travel, auxiliary, swing, boom acceleration and arm boom and arm anti-drift valves	
Pilot control hydraulic system –	
Pump (1)	Gear design
Maximum capacity	4.8 gpm (18.0 L/min)
Relief pressure	566 psi (3.9 MPa)
Swing –	
Motor (1)	Fixed displacement axial piston design
Speed	0-11.5 rpm
Brake	Spring-applied hydraulically released with dual cushion relief
Travel –	
Motor (2)	Two-speed axial piston design
Final drive	Planetary gear reduction
Drawbar pull	42,534 lb (189.2 kN)
Travel Speeds – Auto shift high to low	
	Forward/Reverse
Low	2.1 mph (3.4 km/h)
High	3.5 mph (5.6 km/h)
Travel control valve –	Dual stage relief and counter-balance design

### HYDRAULIC CYLINDERS

Boom cylinders (2) –	
Bore diameter	4.7 in (120 mm)
Rod diameter	3.3 in (85 mm)
Stroke	49.4 in (1255 mm)
Arm cylinder (1) –	
Bore diameter	5.7 in (145 mm)
Rod diameter	4.1 in (105 mm)
Stroke	64.1 in (1627 mm)
Bucket cylinder (1) –	
Bore diameter	3.7 in (95 mm)
Rod diameter	2.6 in (65 mm)
Stroke	34.7 in (881 mm)

### ELECTRICAL

Voltage	24 volts, negative ground
Alternator	50 amp
Batteries (2)	Low-maintenance 92 Ah (5 hr rate)

### SERVICE CAPACITIES

Hydraulic tank	
Refill capacity	39 gal (147 L)
Total system	63 gal (240 L)
Final drive (per side)	4.8 qt (4.5 L)
Swing drive	5.3 qt (5.0 L)
Engine	
w/filter change	24.4 qt (23.1 L)
Fuel	108.3 gal (410 L)
Radiator	27.1 qt (25.6 L)

### OPERATING WEIGHT

With 21 ft 0 in (6.40 m) arm, 31.5 in (800 mm) track shoes, 728 lb (330 kg) bucket, 165 lb (75 kg) operator, full fuel and standard equipment 50,660 lb (22 979 kg)

# LIFT CAPACITIES

21 ft 0 in (6.40 m) Arm Lift capacities calculated using a 728 lb (330 kg) bucket, 11,464 lb (5200 kg) counterweight operating in "Light" Mode.

Load (Lift Point) Height	10 ft (3.05 m)		15 ft (4.57 m)		20 ft (6.10 m)		25 ft (7.62 m)		30 ft (9.14 m)	
	END	SIDE	END	SIDE	END	SIDE	END	SIDE	END	SIDE
+40 ft (12.19 m)										
+35 ft (10.67 m)										
+30 ft (9.14 m)										
+25 ft (7.62 m)										
+20 ft (6.10 m)										
+15 ft (4.57 m)									4,865 lb* (2207 kg)*	4,865 lb* (2207 kg)*
+10 ft (3.05 m)							6,315 lb* (2864 kg)*	6,315 lb* (2864 kg)*	5,615 lb* (2547 kg)*	5,615 lb* (2547 kg)*
+5 ft (1.52 m)	9,065 lb* (4112 kg)*	9,065 lb* (4112 kg)*	13,765 lb* (6244 kg)*	13,765 lb* (6244 kg)*	9,715 lb* (4407 kg)*	9,715 lb* (4407 kg)*	7,765 lb* (3522 kg)*	7,313 lb (3317 kg)	6,415 lb* (2910 kg)*	5,413 lb (2455 kg)
Ground- line	5,865 lb* (2660 kg)*	5,865 lb* (2660 kg)*	14,715 lb* (6675 kg)*	13,363 lb (6061 kg)	11,565 lb* (5246 kg)*	9,013 lb (4088 kg)	8,965 lb* (4066 kg)*	6,563 lb (2977 kg)	7,265 lb* (3295 kg)*	4,963 lb (2251 kg)
-5 ft (-1.52 m)	6,315 lb* (2864 kg)*	6,315 lb* (2864 kg)*	11,415 lb* (5178 kg)*	11,415 lb* (5178 kg)*	13,015 lb* (5903 kg)*	8,163 lb (3703 kg)	9,915 lb* (4497 kg)*	5,963 lb (2705 kg)	7,713 lb (3498 kg)	4,563 lb (2070 kg)
-10 ft (-3.05 m)	7,265 lb* (3295 kg)*	7,265 lb* (3295 kg)*	11,365 lb* (5155 kg)*	11,365 lb* (5155 kg)*	13,513 lb (6129 kg)	7,663 lb (3476 kg)	9,713 lb (4406 kg)	5,613 lb (2546 kg)	7,413 lb (3362 kg)	4,263 lb (1934 kg)
-15 ft (-4.57 m)	8,465 lb* (3840 kg)*	8,465 lb* (3840 kg)*	12,465 lb* (5654 kg)*	11,513 lb (5222 kg)	13,313 lb (6039 kg)	7,513 lb (3408 kg)	9,513 lb (4315 kg)	5,413 lb (2455 kg)	7,263 lb (3294 kg)	4,113 lb (1866 kg)
-20 ft (-6.10 m)	10,215 lb* (4633 kg)*	10,215 lb* (4633 kg)*	14,315 lb* (6493 kg)*	11,813 lb (5358 kg)	13,363 lb (6061 kg)	7,563 lb (3430 kg)	9,463 lb (4292 kg)	5,413 lb (2455 kg)	7,213 lb (3272 kg)	4,063 lb (1843 kg)
-25 ft (-7.62 m)	12,565 lb* (5699 kg)*	12,565 lb* (5699 kg)*	17,165 lb* (7786 kg)*	12,113 lb (5494 kg)	13,365 lb* (6062 kg)*	7,763 lb (3521 kg)	9,613 lb (4360 kg)	5,513 lb (2501 kg)	7,313 lb (3317 kg)	4,163 lb (1888 kg)
-30 ft (-9.14 m)	15,465 lb* (7015 kg)*	15,465 lb* (7015 kg)*	18,165 lb* (8239 kg)*	12,663 lb (5744 kg)	12,265 lb* (5563 kg)*	8,163 lb (3703 kg)	9,665 lb (4384 kg)	5,813 lb (2637 kg)	7,515 lb* (3409 kg)*	4,413 lb (2002 kg)
-35 ft (-10.67 m)	18,265 lb* (8285 kg)*	18,265 lb* (8285 kg)*	13,315 lb* (6039 kg)*	13,113 lb* (5948 kg)	10,165 lb* (4611 kg)*	8,713 lb (3952 kg)	7,865 lb* (3567 kg)*	6,313 lb (2863 kg)		

NOTE: \*Lift capacities do not exceed 75% of the minimum tipping load or 87% of the hydraulic lift capacity.  
Capacities that are marked with an asterisk are hydraulic limited.

## LIFT CAPACITIES (CONT'D)

Load (Lift Point) Height	35 ft (10.67 m)		40 ft (12.19 m)		45 ft (13.72 m)		MAXIMUM REACH		
	END	SIDE	END	SIDE	END	SIDE	@	END	SIDE
+40 ft (12.19 m)							37 ft 5 in (11.40 m)	2,365 lb* (1073 kg)*	2,365 lb* (1073 kg)*
+35 ft (10.67 m)							41 ft 6 in (12.64 m)	2,165 lb* (982 kg)*	2,165 lb* (982 kg)*
+30 ft (9.14 m)			3,715 lb* (1685 kg)*	3,715 lb* (1685 kg)*			44 ft 7 in (13.58 m)	2,115 lb* (959 kg)*	2,115 lb* (959 kg)*
+25 ft (7.62 m)			3,965 lb* (1798 kg)*	3,813 lb (1729 kg)	2,365 lb* (1073 kg)*	2,365 lb* (1073 kg)*	47 ft 0 in (14.32 m)	2,065 lb* (937 kg)*	2,065 lb* (937 kg)*
+20 ft (6.10 m)	4,165 lb* (1889 kg)*	4,165 lb* (1889 kg)*	4,115 lb* (1866 kg)*	3,813 lb (1729 kg)	3,965 lb* (1798 kg)*	2,813 lb (1276 kg)	48 ft 8 in (14.83 m)	2,065 lb* (937 kg)*	2,065 lb* (937 kg)*
+15 ft (4.57 m)	4,565 lb* (2071 kg)*	4,565 lb* (2071 kg)*	4,365 lb* (1980 kg)*	3,613 lb (1639 kg)	4,165 lb* (1889 kg)*	2,713 lb (1230 kg)	49 ft 9 in (15.16 m)	2,115 lb* (959 kg)*	2,013 lb (913 kg)
+10 ft (3.05 m)	5,065 lb* (2297 kg)*	4,463 lb (2024 kg)	4,715 lb* (2139 kg)*	3,413 lb (1548 kg)	4,413 lb (2002 kg)	2,613 lb (1185 kg)	50 ft 4 in (15.34 m)	2,215 lb* (1005 kg)*	1,863 lb (845 kg)
+5 ft (1.52 m)	5,615 lb* (2547 kg)*	4,113 lb (1866 kg)	5,115 lb* (2320 kg)*	3,163 lb (1435 kg)	4,313 lb (1956 kg)	2,463 lb (1117 kg)	50 ft 3 in (15.31 m)	2,365 lb* (1073 kg)*	1,813 lb (822 kg)
Ground- line	6,165 lb* (2796 kg)*	3,813 lb (1729 kg)	5,113 lb (2319 kg)	2,963 lb (1344 kg)	4,163 lb (1888 kg)	2,313 lb (1049 kg)	49 ft 9 in (15.16 m)	2,565 lb* (1163 kg)*	1,763 lb (800 kg)
-5 ft (-1.52 m)	6,113 lb (2773 kg)	3,513 lb (1593 kg)	4,913 lb (2228 kg)	2,763 lb (1253 kg)	4,013 lb (1820 kg)	2,163 lb (981kg)	48 ft 8 in (14.83 m)	2,815 lb* (1277 kg)*	1,813 lb (822 kg)
-10 ft (-3.05 m)	5,863 lb (2659 kg)	3,313 lb (1503 kg)	4,763 lb (2160 kg)	2,613 lb (1185 kg)	3,963 lb (1797 kg)	2,113 lb (958 kg)	46 ft 11 in (14.30 m)	3,165 lb* (1436 kg)*	1,913 lb (868 kg)
-15 ft (-4.57 m)	5,763 lb (2614 kg)	3,213 lb (1457 kg)	4,713 lb (2138 kg)	2,563 lb (1162 kg)	3,913 lb (1775 kg)	2,063 lb (936 kg)	44 ft 6 in (13.56 m)	3,715 lb* (1685 kg)*	2,163 lb (981 kg)
-20 ft (-6.10 m)	5,763 lb (2614 kg)	3,213 lb (1457 kg)	4,713 lb (2138 kg)	2,563 lb (1162 kg)			41 ft 4 in (12.59 m)	4,515 lb* (2048 kg)*	2,513 lb (1140 kg)
-25 ft (-7.62 m)	5,863 lb (2659 kg)	3,313 lb (1503 kg)					37 ft 2 in (11.32 m)	4,665 lb* (2116 kg)*	3,163 lb (1435 kg)
-30 ft (-9.14 m)									
-35 ft (-10.67 m)									

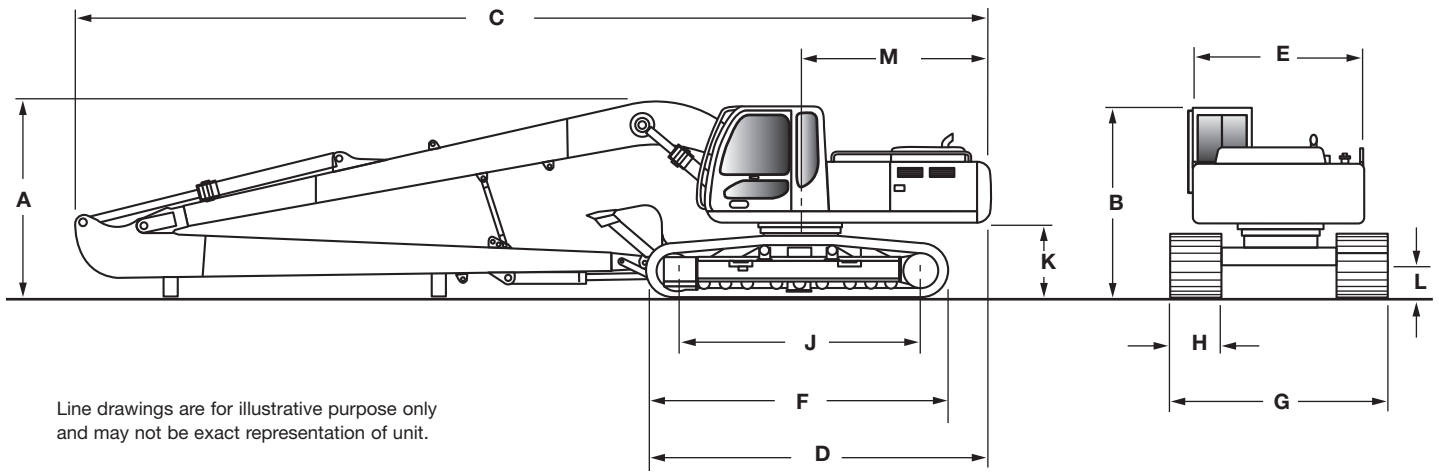

## DIMENSIONS

	<b>21 ft 0 in (6.40 m) Arm</b>
<b>A.</b> Overall height	9 ft 10 in (3.00 m)
<b>B.</b> Cab height	9 ft 8 in (2.94 m)
<b>C.</b> Overall length	40 ft 11 in (12.47 m)
<b>D.</b> w/o attachment	16 ft 3 in (4.96 m)
<b>E.</b> Width of upperstructure	9 ft 1 in (2.77 m)
<b>F.</b> Track overall length	14 ft 8 in (4.47 m)
<b>G.</b> Track overall width w/31.5 in (800 mm) shoes	10 ft 6 in (3.20 m)
<b>H.</b> Track shoe width	31.5 in (800 mm)
<b>J.</b> Center to center (idler to sprocket)	12 ft 0 in (3.66 m)
<b>K.</b> Upperstructure ground clearance	3 ft 5 in (1.04 m)
<b>L.</b> Minimum ground clearance	1 ft 6 in (460 mm)
<b>M.</b> Tail swing radius	9 ft 0 in (2.75 m)
Working weight*	50,660 lb (22 979 kg)
Ground pressure	5.2 psi (36 kPa)

\*With 31.5 in (800 mm) track shoe, 728 lb (330 kg) bucket, 165 lb (75 kg) operator, full fuel and standard equipment.

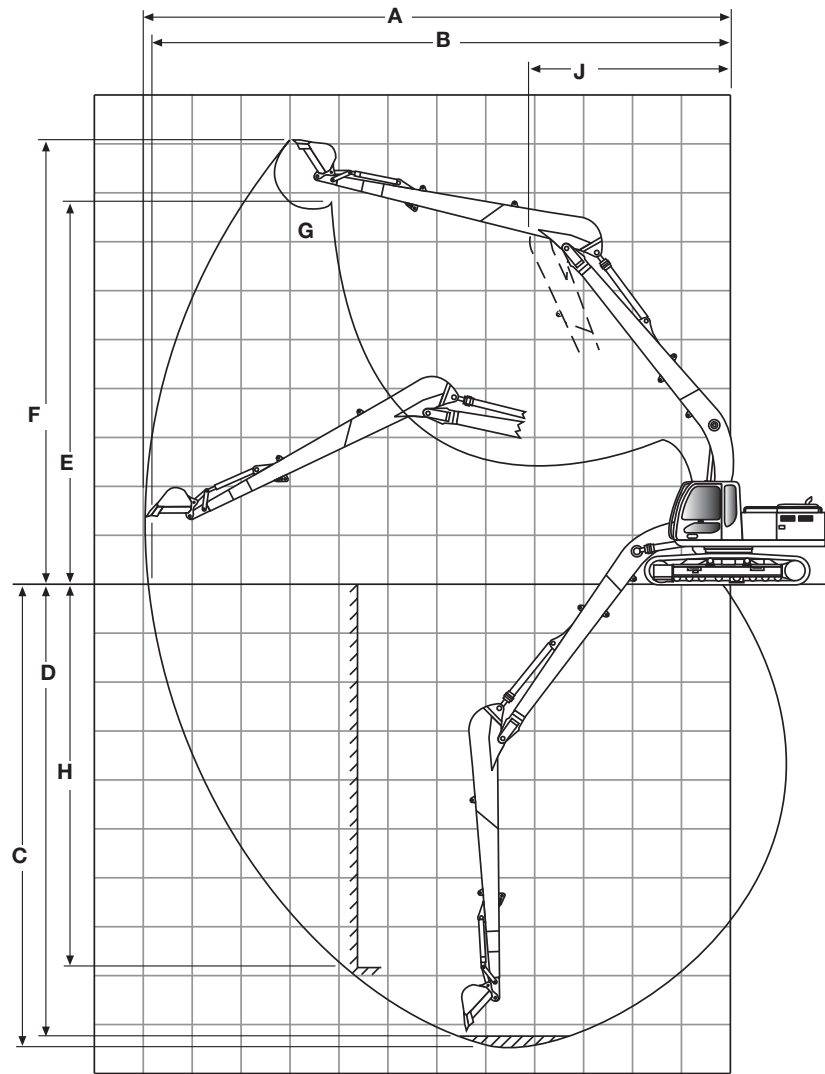

**PERFORMANCE SPECS**

		<b>21 ft 0 in (6.40 m) Arm</b>
<b>A.</b>	Maximum dig radius	51 ft 2 in (15.60 m)
<b>B.</b>	Dig radius at groundline	50 ft 10 in (15.49 m)
<b>C.</b>	Maximum dig depth	39 ft 5 in (12.0 m)
<b>D.</b>	Dig depth - 8 ft 0 in (2.44 m) level bottom	38 ft 9 in (11.82 m)
<b>E.</b>	Dump height	35 ft 2 in (10.73 m)
<b>F.</b>	Overall reach height	42 ft 7 in (12.97 m)
<b>G.</b>	Bucket rotation	178°
<b>H.</b>	Vertical straight wall dig depth	33 ft 9 in (10.28 m)
<b>J.</b>	Minimum swing radius	17 ft 0 in (5.19 m)
Arm digging force		
	Standard	10,341 lb (46.0 kN)
Bucket digging force		
	Standard	14,613 lb (65.0 kN)

## STANDARD EQUIPMENT

### OPERATOR'S COMPARTMENT

Sliding front window - storable  
LCD monitor display  
Skylight  
Cab with Isomount® system  
Adjustable deluxe seat with 3 in (76 mm) retractable seat belt  
Safety glass - all windows  
Climate Control System  
AM/FM Radio w/auto tuner  
Windshield wiper w/washer  
Anti-theft device  
Dome light  
12 volt power supply  
24 volt power supply

### ENGINE

Isuzu 4HK1X turbocharged diesel  
Tier III certified  
Warm up mode  
Selectable one touch or auto accelerator/decelerator  
Dial type throttle control  
Emergency stop  
Auto engine derate

## OPTIONAL EQUIPMENT

### UPPERSTRUCTURE

FOPS guard level 2  
Front screen  
Front grill  
Sun visor  
Rain deflector  
See through skylight

### ELECTRICAL

Batteries (2)  
Electronic Systems Monitor  
Boom worklight  
Turntable worklight

### HYDRAULICS

ISO pattern pilot controls  
Work mode selector: SP, H & Auto  
2 Variable flow piston pumps  
Auto pump destroke  
Arm and boom anti-drift valve  
Attachment cushion control for boom and arm  
100% return oil filtration

### UNDERCARRIAGE

Shoes: 31.5 in (800 mm) 3-bar, 49 per side  
Track length: 14 ft 8 in (4.47 m)  
Track gauge: 7 ft 10 in (2.39 m)  
Sealed and lubed track

### TRACK DRIVE

2-speed hydrostatic travel  
Disc-type parking brakes

### UPPERSTRUCTURE

Boom: 28 ft 7 in (8.70 m) one piece  
Swing brake

### OTHER

Counterweight: 11,464 lb (5200 kg)  
Single key lockup

### HYDRAULICS

Control pattern selector valve

### OTHER

Air suspension seat  
Load holding control devices  
Cylinder mounted

## BUCKETS

Application	Width	SAE Heaped Capacity
General purpose	24 in thru 30 in (0.61 m thru 0.76 m)	0.50 yd <sup>3</sup> thru .66 yd <sup>3</sup> (0.38 m <sup>3</sup> thru 0.50 m <sup>3</sup> )
Ditching	60 in (1.52 m)	1.98 yd <sup>3</sup> (0.83 m <sup>3</sup> )

NOTE: All specifications are stated in accordance with SAE Standards or Recommended Practices, where applicable.

NOTE: All engines meet current EPA emissions requirements.

IMPORTANT: Case Construction Equipment Inc. reserves the right to change these specifications without notice and without incurring any obligation relating to such change. Case Construction Equipment Inc. does not warrant the safety or reliability of attachments from other manufacturers.

Case is a registered trademark of CNH America LLC. Any trademarks referred to herein, in association with goods and/or services of companies other than CNH America LLC, are the property of those respective companies.



[www.casece.com](http://www.casece.com)

