

ENGINE

Model Case 6TAA-5904,
Tier II certified
Type 4-stroke, turbocharged
Cylinders 6
Bore/Stroke 4.02" x 4.72"
(102 x 120 mm)
Displacement 359 in³ (5880 cc)
Fuel injection Direct
Fuel injection pump Electronic
Fuel Diesel
Cooling Liquid
Horsepower per SAE J1349
Gross... 190 hp (142 kW) @ 2200 rpm
Net..... 182 hp (136 kW) @ 2200 rpm
Maximum torque @ 1400 rpm
Net 487 lb-ft (660 N·m)

BOOM/ARM

Boom

Length..... 20'2" (6.15 m)
Boom w/arm cylinder
& plumbing 4,513 lb (2047 kg)
Hoist cylinders (2) .. 518 lb (235 kg) ea
Total weight..... 5,549 lb (2517 kg)

12'0" Arm (3.66 m)

Length..... 12'0" (3.66 m)
Bare arm..... 2,099 lb (952 kg)
Bucket cylinder linkage
& plumbing 948 lb (430 kg)
Total weight..... 3,047 lb (1382 kg)

10'6" Arm (3.2 m)

Length..... 10'6" (3.2 m)
Bare arm..... 1,875 lb (850 kg)
Bucket cylinder linkage
& plumbing 948 lb (430 kg)
Total weight..... 2,823 lb (1280 kg)

8'9" Arm (2.66 m)

Length..... 8'9" (2.66 m)
Bare arm..... 1,684 lb (764 kg)
Bucket cylinder linkage
& plumbing 948 lb (430 kg)
Total weight..... 2,632 lb (1194 kg)

UNDERCARRIAGE

Number of rollers
Top, each track..... 2
Bottom, each track..... 8
Number of shoes
Triple grouser – each side 47
Link pitch 8.5" (215.9 mm)

HYDRAULICS

Pumps (2)..... Variable displacement
axial piston design
Capacity –
Maximum..... 2 x 58.4 gpm
(221 L/min)
System relief pressure –
Standard 4,975 psi (34.3 MPa)
Power Boost.... 5,410 psi (37.3 MPa)
Control valves –
4-spool section for left track travel,
boom, bucket and arm
5-spool section for right track
travel, boom, auxiliary, swing
and arm
Boom and arm anti-drift valves

Pilot control hydraulic system –

Pump (1)..... Gear design
Maximum capacity 5.8 gpm
(22 L/min)
Relief pressure.... 566 psi (3.9 MPa)

Swing –

Motor (1) Fixed displacement
axial piston design
Speed..... 0-10.4 rpm
Brake..... Spring-applied
mechanical disk
Tail swing radius 10'5" (3.18 m)

Travel –

Motor (1) Two-speed
axial piston design
Final drive Planetary gear
reduction
Drawbar pull 53,954 lb (240 kN)

Travel Speeds –

Auto shift high to low
Forward/Reverse
Low 1.9 mph (3.0 km/h)
High..... 3.2 mph (5.1 km/h)

Travel control valve –

Dual stage relief and counter-
balance design

HYDRAULIC CYLINDERS

Boom cylinders (2) –
Bore diameter..... 5.3" (135 mm)
Rod diameter 3.7" (95 mm)
Stroke 53.9" (1369 mm)
Arm cylinder (1) –
Bore diameter..... 5.9" (150 mm)
Rod diameter 4.1" (105 mm)
Stroke 56.6" (1438 mm)
Bucket cylinder (1) –
Bore diameter..... 5.1" (130 mm)
Rod diameter 3.5" (90 mm)
Stroke 42.2" (1073 mm)

ELECTRICAL

Voltage 24 volts,
negative ground
Alternator..... 45 amp
Batteries (2) Low-maintenance
112 Ah (5 hr rate)

SERVICE CAPACITIES

Hydraulic tank
Refill capacity..... 32 gal (120 L)
Total system 63 gal (240 L)
Final drive (per side).... 5.0 qt (4.7 L)
Swing drive..... 6.3 qt (6.0 L)
Engine
w/filter change..... 25.4 qt (24 L)
Fuel..... 90 gal (340 L)
Radiator 30.6 qt (28.9 L)

OPERATING WEIGHT

With 10'6" (3.2 m) arm, 31.5"
(800 mm) track shoes, 1,777 lb
(806 kg) bucket, 165 lb (75 kg)
operator, full fuel and standard
equipment 64,725 lb (29 359 kg)

LIFT CAPACITIES

12' (3.66 m) Arm Lift capacities calculated using a 1,742 lb (790 kg) bucket, 11,905_ lb (5400_ kg) counterweight operating in "Fine" Mode

Load (Lift Point) Height	10' (3.05 m)		15' (4.57 m)		20' (6.1 m)		25' (7.62 m)		30' (9.14 m)		MAXIMUM REACH		
	END	SIDE	END	SIDE	END	SIDE	END	SIDE	END	SIDE	@	END	SIDE
+25' (7.62 m)							7,482lb* (3394 kg)	7,482 lb* (3394 kg)			25'4" (7.72 m)	7,067 lb* (3206 kg)	7,067 lb* (3206 kg)
+20' (6.1 m)							10,738 lb* (4871 kg)	10,738 lb* (4871 kg)			28'4" (8.63 m)	6,876 lb* (3119 kg)	6,876 lb* (3119 kg)
+15' (4.57 m)							13,229 lb* (6001 kg)	11,183 lb (5073 kg)	7,550 lb* (3425 kg)	7,550 lb* (3425 kg)	30'4" (9.25m)	6,992 lb* (3172 kg)	6,992 lb* (3172 kg)
+10' (3.05 m)	35,185 lb* (15 960 kg)	35,185 lb* (15 960 kg)	22,713 lb* (10 302 kg)	22,713 lb* (10 302 kg)	17,727 lb* (8041 kg)	15,287 lb (6934 kg)	15,114 lb* (6856 kg)	10,657 lb (4834 kg)	10,177 lb* (4616 kg)	7,795 lb (3536 kg)	31'4" (9.55 m)	7,381 lb* (3348 kg)	7,227 lb (3278 kg)
+5' (1.52 m)	18,718 lb* (8490 kg)	18,718 lb* (8490 kg)	28,207 lb* (12 794 kg)	22,108 lb (10028 kg)	20,546 lb (9320 kg)	14,283 lb (6479 kg)	15,929 lb (7225 kg)	10,112 lb (4587 kg)	11,884 lb (5390 kg)	7,507 lb (3405 kg)	31'6" (9.60 m)	8,093 lb* (3671 kg)	6,923 lb (3140 kg)
Ground-line	18,311 lb* (8306 kg)	18,311 lb* (8 306 kg)	31,528 lb* (14 301 kg)	20,782 lb (9427 kg)	21,938 lb (9951 kg)	13,508 lb (6127 kg)	15,433 lb (7000 kg)	9,661 lb (4382 kg)	11,627 lb (5274 kg)	7,268 lb (3297 kg)	30'10" (9.40 m)	9,273 lb* (4206 kg)	6,963lb (3158 kg)
-5' (-1.52 m)	23,891 lb* (10 837 kg)	23,891 lb* (10 837 kg)	32,297 lb* (14 650 kg)	20,197 lb (9161 kg)	21,431 lb (9721 kg)	13,062 lb (5925 kg)	15,128 lb (6862 kg)	9,383 lb (4256 kg)			29'4" (8.94 m)	11,280 lb* (5117 kg)	7,401 lb (3357 kg)
-10' (-3.05 m)	32,210 lb* (14 610 kg)	32,210 lb* (14 610 kg)	30,792 lb* (13 967 kg)	20,124 lb (9128 kg)	21,293 lb (9658 kg)	12,941 lb (5870 kg)	15,070 lb (6836 kg)	9,330 lb (4232 kg)			26'10" (8.18 m)	13,607 lb* (6172 kg)	8,455 lb (3835 kg)
-15' (-4.57 m)	37,696 lb* (17 099 kg)	37,696 lb* (17 099 kg)	26,758 lb* (12 137 kg)	20,462 lb (9281 kg)	19,782 lb* (8973 kg)	13,157 lb (5968 kg)					22'11" (6.99 m)	16,396 lb* (7437 kg)	10,819 lb (4907 kg)
-20' (-6.1 m)			18,491 lb* (8387 kg)	18,491 lb* (8387 kg)							16'10" (5.13 m)	16,253 lb* (7372 kg)	16,253 lb* (7372 kg)

10'6" (3.20 m) Arm Lift capacities calculated using a 1,777 lb (806 kg) bucket, 11,905 lb (5400 kg) counterweight operating in "Light" Mode

Load (Lift Point) Height	10' (3.05 m)		15' (4.57 m)		20' (6.1 m)		25' (7.62 m)		MAXIMUM REACH		
	END	SIDE	END	SIDE	END	SIDE	END	SIDE	@	END	SIDE
+25' (7.62 m)									23'2" (7.06 m)	8,375 lb* (3799 kg)	8,375 lb* (3799 kg)
+20' (6.1 m)							10,827 lb* (4911 kg)	10,827 lb (4911 kg)	26'6" (8.07 m)	8,198 lb* (3719 kg)	8,198 lb* (3719 kg)
+15' (4.57 m)					16,213 lb* (7354 kg)	16,075lb (7291 kg)	14,517 lb* (6585 kg)	11,089 lb (5030 kg)	28'7" (8.71 m)	8,415 lb* (3817 kg)	8,415 lb (3817 kg)
+10' (3.05 m)	39,641 lb* (17 981 kg)	39,641 lb* (17 981 kg)	24,688 lb* (11 198 kg)	23,685 lb (10 743 kg)	18,873 lb* (8561 kg)	15,112 lb (6855 kg)	15,918 lb* (7220 kg)	10,599 lb (4808 kg)	29'7" (9.02 m)	8,990 lb* (4078 kg)	7,949 lb (3606 kg)
+5' (1.52 m)	14,474 lb* (6565 kg)	14,474 lb* (6565 kg)	29,706 lb* (13 474 kg)	21,794 lb (9886 kg)	21,467 lb* (9737 kg)	14,181 lb (6432 kg)	15,904 lb (7214 kg)	10,100 lb (4581 kg)	29'10" (9.09 m)	10,009 lb* (4540 kg)	7,610 lb (3452 kg)
Ground-line	18,200 lb* (8255 kg)	18,200 lb* (8255 kg)	32,247 lb* (14 627 kg)	20,710 lb (9394 kg)	21,916 lb (9941 kg)	13,505 lb (6126 kg)	15,471 lb (7018 kg)	9,708 lb (4403 kg)	29'2" (8.89 m)	11,721 lb* (5317 kg)	7,681lb (3484 kg)
-5' (-1.52 m)	25,820 lb* (11 712 kg)	25,820 lb* (11 712 kg)	32,245 lb* (14 626 kg)	20,315 lb (9215 kg)	21,522 lb (9762 kg)	13,158 lb (5968 kg)	15,240 lb (6913 kg)	9,497 lb (4308 kg)	27'6" (8.38 m)	13,172 lb (5975 kg)	8,240 lb (3738 kg)
-10' (-3.05 m)	35,887 lb* (16 278 kg)	35,887 lb* (16 278 kg)	30,001 lb* (13 608 kg)	20,376 lb (9242 kg)	21,492 lb (9749 kg)	13,132 lb (5957 kg)			24'11" (7.11 m)	15,391 lb (6981 kg)	9,600 lb (4354 kg)
-15' (-4.57 m)	34,319 lb* (15 567 kg)	34,319 lb* (15 567 kg)	25,021 lb* (11 349 kg)	20,842 lb (9454 kg)	18,374 lb* (8334 kg)	13,475 lb (6112 kg)			20'7" (6.27 m)	17,582 lb (7975 kg)	12,886 lb (5845 kg)

8'9" (2.67 m) Arm Lift capacities calculated using a 1,777 lb (806 kg) bucket, 11,905 lb (5400 kg) counterweight operating in "Light" Mode

Load (Lift Point) Height	10' (3.05 m)		15' (4.57 m)		20' (6.1 m)		25' (7.62 m)		MAXIMUM REACH		
	END	SIDE	END	SIDE	END	SIDE	END	SIDE	@	END	SIDE
+25 (7.62 m)									21'4" (6.50 m)	10,621 lb* (4818 kg)	10,625 lb (4819 kg)
+20' (6.1 m)					15,667 lb* (7106 kg)	15,667 lb* (7106 kg)			24'11" (7.59 m)	10,396 lb* (4716 kg)	10,396 lb (4716 kg)
+15' (4.57 m)					17,506 lb* (7941 kg)	15,786 lb (7160 kg)	15,551 lb* (7054 kg)	10,924 lb (4955 kg)	27'1" (8.25 m")	10,706 lb* (4856 kg)	9,515 lb (4316 kg)
+10' (3.05 m)			26,731 lb* (12 125 kg)	23,067 lb (10 463 kg)	20,009 lb* (9076 kg)	14,859 lb (6740 kg)	16,312 lb (7399 kg)	10,477 lb (4752kg)	28'2" (8.58 m)	11,503 lb* (5218 kg)	8,593 lb (3898 kg)
+5' (1.52 m)			31,074 lb* (14 095 kg)	21,382 lb (9699 kg)	22,305 lb* (10 117 kg)	14,008 lb (6354 kg)	15,821 lb (7176 kg)	10,031 lb (4550 kg)	28'5" (8.66 m)	12,920 lb* (5860 kg)	8,228 lb (3732 kg)
Ground-line	16,188 lb* (7343 kg)	16,188 lb* (7343 kg)	32,618 lb* (14 795 kg)	20,573 lb (9332 kg)	21,833 lb (9903 kg)	13,439 lb (6096 kg)	15,462 lb (7013 kg)	9,704 lb (4402 kg)	27'8" (8.43 m)	13,260 lb (6015 kg)	8,349 lb (3787 kg)
-5' (-1.52 m)	27,341 lb* (12 402 kg)	27,341 lb* (12 402 kg)	31,715 lb* (14 386 kg)	20,381 lb (9245 kg)	21,565 lb (9782 kg)	13,204 lb (5989 kg)	15,323 lb (6950 kg)	9,578 lb (4345 kg)	26'0" (7.92 m)	14,470 lb (6563 kg)	9,067 lb (4113 kg)
-10' (-3.05 m)	39,030 lb* (17 704 kg)	39,030 lb* (17 704 kg)	28,609 lb* (12 977 kg)	20,591 lb (9340 kg)	21,447 lb* (9728 kg)	13,295 lb (6031 kg)			23'1" (7.03 m)	17,369 lb (7878 kg)	10,833 lb (4914 kg)
-15' (-4.57 m)	29,622 lb* (13 436 kg)	29,622 lb* (13 436 kg)	22,369 lb* (10 146 kg)	21,229 lb (9629 kg)					18'6" (5.64 m)	17,896 lb* (8117 kg)	15,501 lb (7031 kg)

*Lift capacities do not exceed 75% of the minimum tipping load or 87% of the hydraulic lift capacity. Capacities that are marked with an asterisk are hydraulic limited.

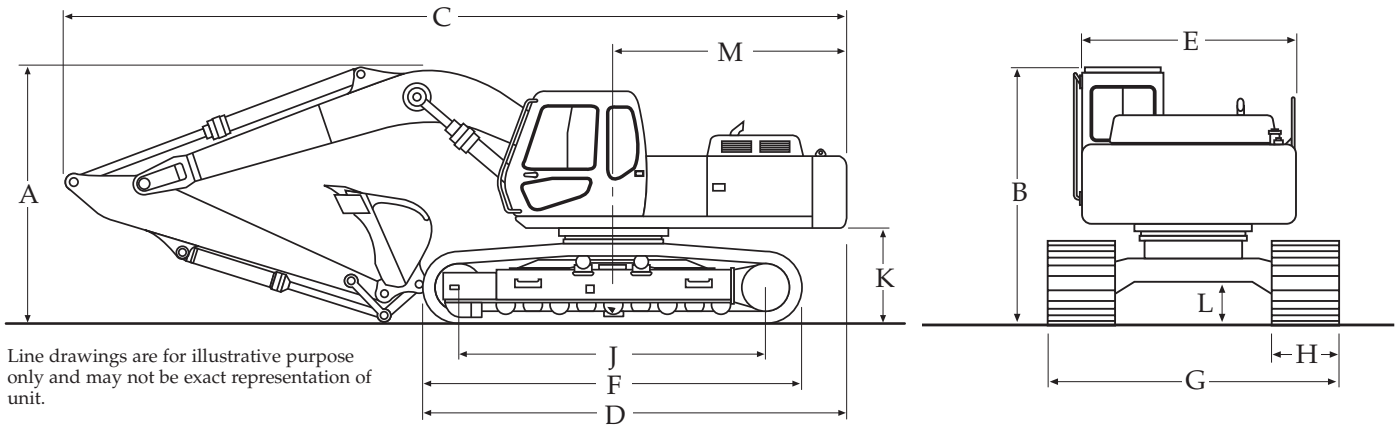

DIMENSIONS

	12'0" (3.66 m) Arm	10'6" (3.2 m) Arm	8'9" (2.7 m) Arm
A. Overall height	11'5" (3.48m)	10'9" (3.28 m)	10'9" (3.28 m)
B. Cab height	10'0" (3.05 m)	10'0" (3.05 m)	10'0" (3.05 m)
C. Overall length	34'3" (10.43 m)	34'2" (10.41 m)	34'2" (10.41 m)
D. w/o attachment	18'5" (5.62 m)	18'5" (5.62 m)	18'5" (5.62 m)
E. Width of upperstructure	9'2" (2.79 m)	9'2" (2.79 m)	9'2" (2.79 m)
F. Track overall length	16'0" (4.88 m)	16'0" (4.88 m)	16'0" (4.88 m)
G. Track overall width w/31.5" (800 mm) shoes	11'2" (3.40 m)	11'2" (3.40 m)	11'2" (3.40 m)
H. Track shoe width	31.5" (800 mm)	31.5" (800 mm)	31.5" (800 mm)
J. Center to center (idler to sprocket)	12'11" (3.93 m)	12'11" (3.93 m)	12'11" (3.93 m)
K. Upperstructure ground clearance	3'11" (1.20 m)	3'11" (1.20 m)	3'11" (1.20 m)
L. Minimum ground clearance	1'7" (0.49 m)	1'7" (0.49 m)	1'7" (0.49 m)
M. Tail swing radius	10'5" (3.18 m)	10'5" (3.18 m)	10'5" (3.18 m)
Working weight*	64,980 lb (29 474 kg)	64,725 lb (29 359 kg)	64,496 lb (29 255 kg)
Ground pressure	6.2 psi (43.0 kPa)	6.1 psi (42.0 kPa)	6.1 psi (42.0 kPa)

*With 31.5" (800 mm) track shoe, 1,777 lb (806 kg) bucket, 165 lb (75 kg) operator, full fuel and standard equipment.

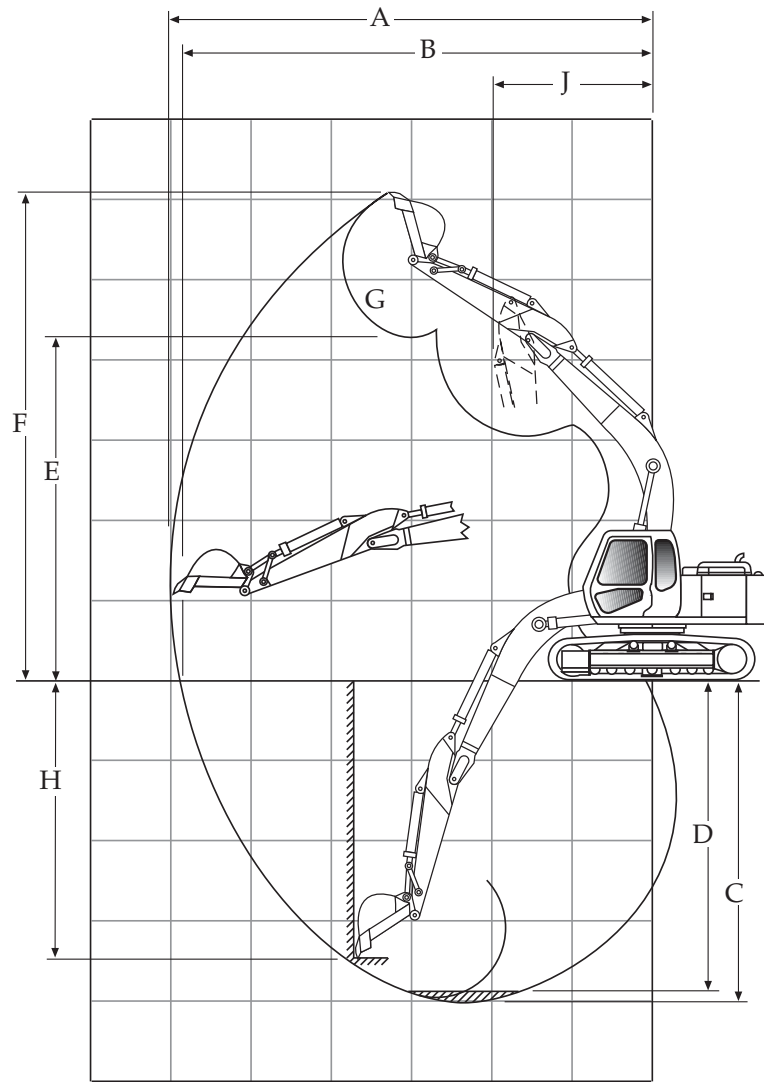

PERFORMANCE SPECS

	12'0" (3.66 m) Arm	10'6" (3.2 m) Arm	8'9" (2.7 m) Arm
A. Maximum dig radius	36'8" (11.18 m)	35'2" (10.73 m)	33'10" (10.32 m)
B. Dig radius at groundline	36'1" (11.00 m)	34'7" (10.54 m)	33'2" (10.10 m)
C. Maximum dig depth	24'11" (7.59 m)	23'5" (7.15 m)	21'9" (6.64 m)
D. Dig depth - 8'0" (2.44 m) level bottom	24'5" (7.45 m)	22'10" (6.97 m)	21'1" (6.42 m)
E. Dump height	24'2" (7.36 m)	23'3" (7.09 m)	22'11" (6.99 m)
F. Overall reach height	34'1" (10.39 m)	33'2" (10.11 m)	32'11" (10.03 m)
G. Bucket rotation	180°	180°	180°
H. Vertical straight wall dig depth	21'10" (6.65 m)	19'10" (6.04 m)	18'7" (5.66 m)
J. Minimum swing radius	12'11" (3.93 m)	12'10" (3.90 m)	13'1" (4.00 m)
Arm digging force			
Standard	23,605 lb (105.0 kN)	25,853 lb (115 kN)	29,225 lb (130 kN)
Power Boost	25,628 lb (114.0 kN)	28,101 lb (125 kN)	31,923 lb (142 kN)
Bucket digging force			
Standard	35,969 lb (160 kN)	35,969 lb (160 kN)	35,969 lb (160 kN)
Power Boost	38,892 lb (173 kN)	38,892 lb (173 kN)	38,892 lb (173 kN)

STANDARD EQUIPMENT

OPERATOR'S COMPARTMENT

Cab with Isomount® system
Adjustable deluxe seat with
3" (76 mm) retractable seat belt
Vandal cover
Front window safety glass
Climate Control System
AM/FM Radio w/auto tuner
Roof hatch, skylight
Sliding Lexan™ windows
Windshield wiper w/washer

ENGINE

Case 6TAA-5904 turbocharged diesel
Tier II certified
Warm up mode
Selectable one touch or auto
accelerator/decelerator

ELECTRICAL

Batteries (2)
Electronic Systems Monitor

HYDRAULICS

ISO pattern pilot controls
4 Position mode selector:
H, S, L & Auto
Power Boost
2 Variable flow piston pumps
Auxiliary attachment mode
Neutral pump destroke
Auxiliary hydraulic valve
Boom and arm anti-drift valves
Selectable cushion control
for boom and arm
Controlled free swing
Ultra Clean filtration system

UNDERCARRIAGE

Shoes: 31.5" (800 mm) 3-bar,
47 per side
Track length: 16'0" (4.88 m)
Track gauge: 8'6" (2.59 m)

TRACK DRIVE

2-speed hydrostatic travel
Straight tracking travel priority
Disc-type parking brakes

UPPERSTRUCTURE

Boom: 20'2" (6.15 m) one piece
Free swing control
Hammer adaptable, no
reinforcing required
Swing brake

OTHER

Counterweight: 11,927 lb (5410 kg)
Single key vandal lockup

OPTIONAL EQUIPMENT

UPPERSTRUCTURE

Arm: 12'0", 10'6" or 8'9"
(3.66 m, 3.2 m or 2.7 m)

HYDRAULICS

Auxiliary hydraulics
Single acting, one pump (includes
heavy-duty bucket linkage)
Double acting, single or dual
pump (includes heavy-duty
bucket linkage)
Double acting general purpose
for use with thumb kit
Control pattern selector valve

OTHER

Load holding control devices
Cylinder mounted
Case/JRB Slide-Loc® Hydraulic
Coupler

BUCKETS

Application

Width

SAE Heaped Capacity

General purpose	30" to 54" (0.76 to 1.37 m)	0.79 yd ³ to 2.15 yd ³ (0.60 m ³ to 1.64 m ³)
Heavy-duty plate lip	24" to 54" (0.61 to 1.37 m)	0.79 yd ³ to 2.15 yd ³ (0.60 m ³ to 1.64 m ³)
Heavy-duty cast lip	30" to 39" (0.76 to 0.99 m)	0.96 yd ³ to 1.34 yd ³ (0.73 m ³ to 1.02 m ³)
Extreme-duty rate lip	24" to 48" (0.61 to 1.22 m)	0.69 yd ³ to 1.67 yd ³ (0.53 m ³ to 1.28 m ³)
Ditching	60" to 66" (1.52 to 1.67 m)	1.30 yd ³ to 1.45 yd ³ (0.99 m ³ to 1.11 m ³)

This page intentionally left blank.

NOTE: All specifications are stated in accordance with SAE Standards or Recommended Practices, where applicable.

NOTE: All engines meet current EPA emissions requirements.

IMPORTANT: CNH America LLC reserves the right to change these specifications without notice and without incurring any obligation relating to such change. CNH America LLC does not warrant the safety or reliability of attachments from other manufacturers.

Case is a registered trademark of CNH America LLC. Any trademarks referred to herein, in association with goods and/or services of companies other than CNH America LLC, are the property of those respective companies.



www.casece.com



CASE IS A BRAND OF CNH, A GLOBAL LEADER FOR CONSTRUCTION EQUIPMENT, AGRICULTURAL EQUIPMENT AND FINANCIAL SERVICES.