

CX330

**LR EXCAVATOR
TIER II CERTIFIED**

ENGINE

Model	Case 6TAA-8304, Tier II certified
Type	4-stroke, turbocharged
Cylinders	6
Bore/Stroke	4.49 in x 5.31 in (114 x 135 mm)
Displacement	505 in ³ (8270 cc)
Fuel injection	Direct
Fuel injection pump	Electronic
Fuel	Diesel
Cooling	Liquid
Horsepower per SAE J1349	
Gross	275 hp (205 kW) @ 2000 rpm
Net	259 (193 kW) @ 2000 rpm
Maximum torque @ 1400 rpm	
Net	793 lb-ft (1075 N-m)

BOOM/ARM

Boom	
Length	39 ft 4 in (12.00 m)
Boom w/arm cylinder & plumbing	9,833 lb (4460 kg)
Hoist cylinders (2)	761 lb (345 kg) ea
Total weight	11,353 lb (5150 kg)

30 ft 6 in Arm (9.30 m)

Length	30 ft 6 in (9.30 m)
Bare arm	4,519 lb (2050 kg)
Bucket cylinder linkage & plumbing	468 lb (212 kg)
Total weight	4,988 lb (2262 kg)

UNDERCARRIAGE

Number of rollers	
Top, each track	2
Bottom, each track	8
Number of shoes	
Triple grouser – each side	48
Link pitch	8.5 in (215.9 mm)

HYDRAULICS

Pumps (2)	Variable displacement axial piston design
Capacity –	
Maximum	2 x 75 gpm (284 L/min)
System relief pressure –	
Standard	4,975 psi (34.3 MPa)
Power Boost	5,410 psi (37.3 MPa)
Control valves –	
4-spool section for left track travel, boom, bucket and arm	
5-spool section for right track travel, boom, auxiliary, swing and arm	
Boom and arm anti-drift valves	
Pilot control hydraulic system –	
Pump (1)	Gear design
Maximum capacity	8.1 gpm (30.5 L/min)
Relief pressure	566 psi (3.9 MPa)
Swing –	
Motor (1)	Fixed displacement axial piston design
Speed	0-9.6 rpm
Brake	Spring-applied hydraulically released with dual cushion relief
Tail swing radius	11 ft 10 in (3.60 m)
Travel –	
Motor (1)	Two-speed axial piston design
Final drive	Planetary gear reduction
Drawbar pull	60,923 lb (271 kN)
Travel Speeds –	
Auto shift high to low	
	Forward/Reverse
Low	2.0 mph (3.2 km/h)
High	3.4 mph (5.5 km/h)
Travel control valve –	Dual stage relief and counter-balance design

HYDRAULIC CYLINDERS

Boom cylinders (2) –	
Bore diameter	5.7 in (145 mm)
Rod diameter	3.9 in (100 mm)
Stroke	58.9 in (1495 mm)
Arm cylinder (1) –	
Bore diameter	6.7 in (170 mm)
Rod diameter	4.7 in (120 mm)
Stroke	68.8 in (1748 mm)
Bucket cylinder (1) –	
Bore diameter	3.7 in (95 mm)
Rod diameter	2.6 in (65 mm)
Stroke	34.7 in (881 mm)

ELECTRICAL

Voltage	24 volts, negative ground
Alternator	50 amp
Batteries (2)	Low-maintenance 140 Ah (5 hr rate)

SERVICE CAPACITIES

Hydraulic tank	
Refill capacity	46 gal (175 L)
Total system	92 gal (350 L)
Final drive (per side)	11.6 qt (11 L)
Swing drive	6.3 qt (6.0 L)
Engine	
w/filter change	22.2 qt (21 L)
Fuel	153 gal (580 L)
Radiator	46.5 qt (44 L)

OPERATING WEIGHT

With 10 ft 8 in (3.25 m) arm, 31.5 in (800 mm) track shoes, 899 lb (408 kg) bucket, 165 lb (75 kg) operator, full fuel and standard equipment	90,294 lb (40 957 kg)
---	-----------------------

LIFT CAPACITIES

30 ft 6 in (9.30 m) Arm Lift capacities calculated using a 899 lb (408 kg) bucket operating in "Light" Mode.

Load (Lift Point) Height	15 ft (4.57 m)		20 ft (6.10 m)		25 ft (7.62 m)		30 ft (9.14 m)		35 ft (10.67 m)		40 ft (12.19 m)	
	END	SIDE	END	SIDE	END	SIDE	END	SIDE	END	SIDE	END	SIDE
+40 ft (12.19 m)												
+35 ft (10.67 m)												
+30 ft (9.14 m)												
+25 ft (7.62 m)												
+20 ft (6.10 m)												
+15 ft (4.57 m)												
+10 ft (3.05 m)	7,678 lb* (3483 kg)	7,678 lb* (3483 kg)									6,878 lb* (3120 kg)	6,878 lb* (3120 kg)
+5 ft (1.52 m)	2,878 lb* (1305 kg)	2,878 lb* (1305 kg)	9,728 lb* (4412 kg)	9,728 lb* (4412 kg)	15,078 lb* (6839 kg)	15,078 lb* (6839 kg)	11,328 lb* (5138 kg)	11,328 lb* (5138 kg)	9,028 lb* (4095 kg)	9,028 lb* (4095 kg)	7,528 lb* (3415 kg)	7,528 lb* (3415 kg)
Ground- line	3,028 lb* (1373 kg)	3,028 lb* (1373 kg)	6,728 lb* (3052 kg)	6,728 lb* (3052 kg)	14,278 lb* (6476 kg)	14,278 lb* (6476 kg)	12,478 lb* (5660 kg)	12,478 lb* (5660 kg)	9828 lb* (4458 kg)	9828 lb* (4458 kg)	8,128 lb* (3687 kg)	8,128 lb* (3687 kg)
-5 ft (-1.52 m)	3,828 lb* (1736 kg)	3,828 lb* (1736 kg)	6,378 lb* (2893 kg)	6,378 lb* (2893 kg)	11,328 lb* (5138 kg)	11,328 lb* (5138 kg)	13,328 lb* (6045 kg)	11,988 lb* (5438 kg)	10,528 lb* (4775 kg)	9,438 lb* (4281 kg)	8,628 lb* (3913 kg)	7,588 lb* (3442 kg)
-10 ft (-3.05 m)	4,728 lb* (2144 kg)	4,728 lb* (2144 kg)	6,828 lb* (3097 kg)	6,828 lb* (3097 kg)	10,678 lb* (4843 kg)	10,678 lb* (4843 kg)	13,878 lb* (6295 kg)	11,088 lb* (5029 kg)	10,978 lb* (4979 kg)	8,688 lb* (3941 kg)	8,978 lb* (4072 kg)	6,988 lb* (3170 kg)
-15 ft (-4.57 m)	5,728 lb* (2598 kg)	5,728 lb* (2598 kg)	7,628 lb* (3460 kg)	7,628 lb* (3460 kg)	10,928 lb* (4957 kg)	10,928 lb* (4957 kg)	14,128 lb* (6408 kg)	10,588 lb* (4803 kg)	11,278 lb* (5116 kg)	8,188 lb* (3714 kg)	9,278 lb* (4208 kg)	6,588 lb* (2988 kg)
-20 ft (-6.10 m)	6,778 lb* (3074 kg)	6,778 lb* (3074 kg)	8,578 lb* (3891 kg)	8,578 lb* (3891 kg)	11,678 lb* (5297 kg)	11,678 lb* (5297 kg)	14,128 lb* (6408 kg)	10,338 lb* (4689 kg)	11,328 lb* (5138 kg)	7,938 lb* (3601 kg)	9,328 lb* (4231 kg)	6,338 lb* (2875 kg)
-25 ft (-7.62 m)	7,928 lb* (3596 kg)	7,928 lb* (3596 kg)	9,728 lb* (4412 kg)	9,728 lb* (4412 kg)	12,728 lb* (5773 kg)	12,728 lb* (5773 kg)	13,828 lb* (6272 kg)	10,288 lb* (4666 kg)	11,178 lb* (5070 kg)	7,838 lb* (3555 kg)	9,278 lb* (4208 kg)	6,188 lb* (2807 kg)
-30 ft (-9.14 m)	9,078 lb* (4118 kg)	9,078 lb* (4118 kg)	10,978 lb* (4979 kg)	10,978 lb* (4979 kg)	14,078 lb* (6386 kg)	14,078 lb* (6386 kg)	13,228 lb* (6000 kg)	10,438 lb* (4734 kg)	10,778 lb* (4889 kg)	7,888 lb* (3578 kg)	8,978 lb* (4072 kg)	6,238 lb* (2829 kg)
-35 ft (-10.67 m)	10,278 lb* (4662 kg)	10,278 lb* (4662 kg)	12,378 lb* (5614 kg)	12,378 lb* (5614 kg)	15,278 lb* (6930 kg)	15,188 lb* (6889 kg)	12,278 lb* (5569 kg)	10,738 lb* (4871 kg)	10,078 lb* (4571 kg)	8,088 lb* (3669 kg)	8,428 lb* (3823 kg)	6,388 lb* (2897 kg)
-40 ft (-12.19 m)	11,528 lb* (5229 kg)	11,528 lb* (5229 kg)	13,878 lb* (6295 kg)	13,878 lb* (6295 kg)	13,428 lb* (6091 kg)	13,428 lb* (6091 kg)	10,928 lb* (4957 kg)	10,928 lb* (4957 kg)	9,028 lb* (4095 kg)	8,438 lb* (3827 kg)	7,528 lb* (3415 kg)	6,688 lb* (3034 kg)
-45 ft (-13.72 m)	12,778 lb* (5796 kg)	12,778 lb* (5796 kg)	13,578 lb* (6159 kg)	13,578 lb* (6159 kg)	10,978 lb* (4979 kg)	10,978 lb* (4979 kg)	9,028 lb* (4095 kg)	9,028 lb* (4095 kg)	7,478 lb* (3392 kg)	7,478 lb* (3392 kg)	6,128 lb* (2780 kg)	6,128 lb* (2780 kg)
-50 (-15.24 m)					7,578 lb* (3437 kg)	7,578 lb* (3437 kg)	6,328 lb* (2870 kg)	6,328 lb* (2870 kg)	5,078 lb* (2303 kg)	5,078 lb* (2303 kg)		

NOTE: *Lift capacities do not exceed 75% of the minimum tipping load or 87% of the hydraulic lift capacity.
Capacities that are marked with an asterisk are hydraulic limited.

LIFT CAPACITIES (CONT'D)

30 ft 6 in (9.30 m) Arm Lift capacities calculated using a 899 lb (408 kg) bucket operating in "Light" Mode.

Load (Lift Point) Height	45 ft (13.72 m)		50 ft (15.24 m)		55 ft (16.76 m)		60 in (18.29 m)		MAXIMUM REACH		
	END	SIDE	END	SIDE	END	SIDE	END	SIDE	@	END	SIDE
+40 ft (12.19 m)					1,878 lb* (852 kg)	1,878 lb* (852 kg)			55 ft 4 in (16.86 m)	1,728 lb* (784 kg)	1,728 lb* (784 kg)
+35 ft (10.67 m)					3,078 lb* (1396 kg)	3,078 lb* (1396 kg)			58 ft 0 in (17.67 m)	1,678 lb* (761 kg)	1,678 lb* (761 kg)
+30 ft (9.14 m)					3,728 lb* (1691 kg)	3,728 lb* (1691 kg)	1,828 lb* (829 kg)	1,828 lb* (829 kg)	60 ft 11 in (18.56 m)	1,678 lb* (761 kg)	1,678 lb* (761 kg)
+25 ft (7.62 m)					3,828 lb* (1736 kg)	3,828 lb* (1736 kg)	2,778 lb* (1260 kg)	2,778 lb* (1260 kg)	61 ft 11 in (18.87 m)	1,728 lb* (784 kg)	1,728 lb* (784 kg)
+20 ft (6.10 m)					3,978 lb* (1804 kg)	3,978 lb* (1804 kg)	3,578 lb* (1623 kg)	3,578 lb* (1623 kg)	63 ft 3 in (19.27 m)	1,778 lb* (806 kg)	1,778 lb* (806 kg)
+15 ft (4.57 m)			4,928 lb* (2235 kg)	4,928 lb* (2235 kg)	4,178 lb* (1895 kg)	4,178 lb* (1895 kg)	3,878 lb* (1759 kg)	3,588 lb* (1627 kg)	64 ft 1 in (19.53 m)	1,828 lb* (829 kg)	1,828 lb* (829 kg)
+10 ft (3.05 m)	5,978 lb* (2711 kg)	5,978 lb* (2711 kg)	5,278 lb* (2394 kg)	5,278 lb* (2394 kg)	4,328 lb* (1963 kg)	4,238 lb* (1922 kg)	4,028 lb* (1827 kg)	3,388 lb* (1537 kg)	64 ft 6 in (19.65 m)	1,978 lb* (897 kg)	1,978 lb* (897 kg)
+5 ft (1.52 m)	6,428 lb* (2916 kg)	6,428 lb* (2916 kg)	5,628 lb* (2553 kg)	5,628 lb* (2553 kg)	4,528 lb* (2054 kg)	3,938 lb* (1786 kg)	4,128 lb* (1872 kg)	3,138 lb* (1423 kg)	64 ft 7 in (19.68 m)	2,128 lb* (965 kg)	2,128 lb* (965 kg)
Ground- line	6,878 lb* (3120 kg)	6,738 lb* (3056kg)	5,978 lb* (2711 kg)	5,488 lb* (2489 kg)	4,728 lb* (2144 kg)	3,638 lb* (1650 kg)	4,278 lb* (1940 kg)	2,938 lb* (1333 lb)	64 ft 3 in (19.58 m)	2,328 lb* (1056 kg)	2,328 lb* (1056 kg)
-5 ft (-1.52 m)	7,278 lb* (3301 kg)	6,188 lb* (2807 kg)	6,278 lb* (2848 kg)	5,038 lb* (2285 kg)	4,878 lb* (2213 kg)	3,388 lb* (1537 kg)	4,378 lb* (1986 kg)	2,788 lb* (1265 kg)	64 ft 6 in (19.65 m)	2,578 lb* (1169 kg)	2,388 lb* (1083 kg)
-10 ft (- 3.05 m)	7,578 lb* (3437 kg)	5,688 lb* (2580 kg)	6,478 lb* (2938 kg)	4,688 lb* (2126 kg)	5,028 lb* (2281 kg)	3,188 lb* (1446 kg)	4,478 lb* (2031 kg)	2,638 lb* (1196 kg)	62 ft 4 in (18.99 m)	2,928 lb* (1328 kg)	2,388 lb* (1083 kg)
-15 ft (- 4.57 m)	7,778 lb* (3528 kg)	5,388 lb* (2444 kg)	6,678 lb* (3029 kg)	4,438 lb* (2013 kg)	5,078 lb* (2303 kg)	3,038 lb* (1378 kg)	4,228 lb* (1918 kg)	2,538 lb* (1151 kg)	60 ft 10 in (18.54 m)	3,378 lb* (1532 kg)	2,488 lb* (1128 kg)
-20 ft (- 6.10 m)	7,878 lb* (3573 kg)	5,138 lb* (2330 kg)	6,728 lb* (3052 kg)	4,238 lb* (1922 kg)	5,028 lb* (2281 kg)	2,938 lb* (1333 kg)			58 ft 9 in (17.90 m)	3,928 lb* (1782 kg)	2,588 lb* (1174 kg)
-25 ft (- 7.62 m)	7,828 lb* (3551 kg)	5,038 lb* (2285 kg)	6,678 lb* (3029 kg)	4,138 lb* (1877 kg)	4,878 lb* (2213 kg)	2,938 lb* (1333 kg)			56 ft 2 in (17.11 m)	4,728 lb* (2144 kg)	2,838 lb* (1287 kg)
-30 ft (- 9.14 m)	7,578 lb* (3437 kg)	5,038 lb* (2285 kg)	6,428 lb* (2916 kg)	4,188 lb* (1900 kg)	5,428 lb* (2462 kg)	3,538 lb* (1605 kg)			53 ft 0 in (16.15 m)	4,878 lb* (2213 kg)	3,188 lb* (1446 kg)
-35 ft (- 10.67 m)	7,078 lb* (3210 kg)	5,188 lb* (2353 kg)	5,928 lb* (2689 kg)	4,288 lb* (1945 kg)					49 ft 2 in (14.98 m)	5,078 lb* (2303 kg)	3,788 lb* (1718 kg)
-40 ft (- 12.19 m)	6,228 lb* (2825 kg)	5,438 lb* (2467 kg)							44 ft 4 in (13.51 m)	5,228 lb* (2371 kg)	4,688 lb* (2126 kg)
-45 ft (- 13.72 m)									38 ft 4 in (11.68 m)	5,278 lb* (2394 kg)	5,278 lb* (2394 kg)
-50 ft (- 15.24 m)									30 ft 4 in (9.24 m)	5,028 lb* (2281 kg)	5,028 lb* (2281 kg)

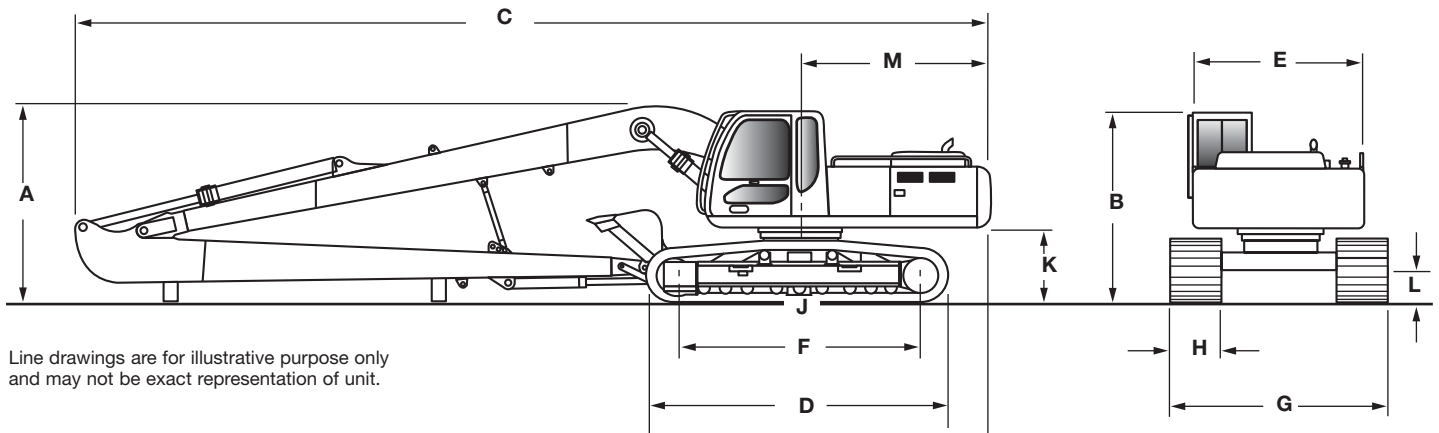

DIMENSIONS

	30 ft 6 in (9.30 m) Arm
A. Overall height	11 ft 6 in (3.50 m)
B. Cab height	10 ft 1 in (3.07 m)
C. Overall length	55 ft 0 in (16.77 m)
D. w/o attachment	19 ft 11 in (6.06 m)
E. Width of upperstructure	10 ft 0 in (3.04 m)
E. Width of upperstructure w/catwalks	11 ft 9 in (3.58 m)
F. Track overall length	16 ft 4 in (4.98 m)
G. Track overall width w/31.5 in (800 mm) shoes	11 ft 2 in (3.40 m)
H. Track shoe width	31.5 in (800 mm)
J. Center to center (idler to sprocket)	13 ft 3 in (4.04 m)
K. Upperstructure ground clearance	4 ft 0 in (1.21 m)
L. Minimum ground clearance	1 ft 7 in (0.48 m)
M. Tail swing radius	11 ft 10 in (3.60 m)
Working weight*	90,294 lb (40 957 kg)
Ground pressure	8.6 psi (60 kPa)

*With 31.5 in (800 mm) track shoe, 899 lb (408 kg) bucket, 165 lb (75 kg) operator, full fuel and standard equipment.

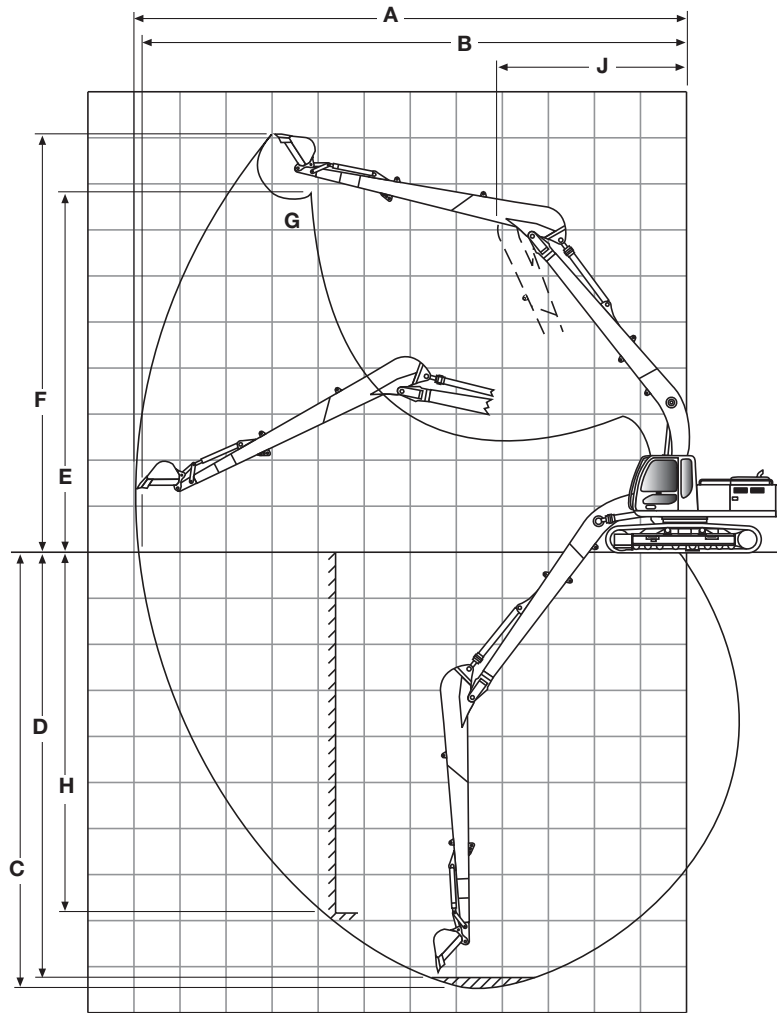

PERFORMANCE SPECS

	30 ft 6 in (9.30 m) Arm
A. Maximum dig radius	69 ft 1 in (21.05 m)
B. Dig radius at groundline	68 ft 9 in (20.95 m)
C. Maximum dig depth	55 ft 0 in (16.77 m)
D. Dig depth – 8 ft 0 in (2.44 m) level bottom	54 ft 7 in (16.64 m)
E. Dump height	42 ft 10 in (13.06 m)
F. Overall reach height	49 ft 10 in (15.20 m)
G. Bucket rotation	178°
H. Vertical straight wall dig depth	46 ft 3 in (14.09 m)
J. Minimum swing radius	24 ft 4 in (7.41 m)
Arm digging force	
Standard	14,410 lb (64.1 kN)
Bucket digging force	
Standard	9,869 lb (43.9 kN)

STANDARD EQUIPMENT

OPERATOR'S COMPARTMENT

Cab with Isomount® system
Adjustable deluxe seat with
3 in (76 mm) retractable seat belt
Front window safety glass
Climate Control System
AM/FM Radio w/auto tuner
Roof hatch, skylight
Sliding Lexan® windows
Windshield wiper w/washer
Anti-theft device

ENGINE

Case 6TAA-8304 turbocharged diesel
Tier II certified
Warm up mode
Selectable one touch or auto
accelerator/decelerator
Auto engine de-rate

ELECTRICAL

Batteries (2)
Electronic Systems Monitor
Horn, dual

HYDRAULICS

ISO pattern pilot controls
4 Position mode selector: H, S, L & Auto
Auto Power Boost
2 Variable flow piston pumps
Auxiliary attachment mode
Neutral pump destroke
Auxiliary hydraulic valve
Boom and arm anti-drift valves
Selectable cushion control for boom and arm
Controlled free swing
Ultra Clean filtration system

UNDERCARRIAGE

Shoes: 31.5 in (800 mm) 3-bar, 48 per side
Track length: 16 ft 4 in (4.98 m)
Track gauge: 8 ft 6 in (2.59 m)
Sealed and lubed track

TRACK DRIVE

2-speed hydrostatic travel
Straight tracking travel priority
Disc-type parking brakes

UPPERSTRUCTURE

Boom: 21 ft 2 in (6.45 m) one piece
Free swing control
Hammer adaptable
Swing brake

OTHER

Counterweight: 26,610 lb (12 070 kg)
Single key lockup

BUCKETS

Application	Width	SAE Heaped Capacity
General purpose	24 in to 30 in (0.60 to 0.91 m)	0.50 yd ³ to 0.60 yd ³ (0.38 m ³ to 0.46 m ³)
Ditching	60 in to 66 in (1.52 to 1.68 m)	0.86 yd ³ to 0.96 yd ³ (0.66 m ³ to 0.73 m ³)

NOTE: All specifications are stated in accordance with SAE Standards or Recommended Practices, where applicable.

NOTE: All engines meet current EPA emissions requirements.

IMPORTANT: CNH America LLC reserves the right to change these specifications without notice and without incurring any obligation relating to such change. CNH America LLC does not warrant the safety or reliability of attachments from other manufacturers.

Case is a registered trademark of CNH America LLC. Any trademarks referred to herein, in association with goods and/or services of companies other than CNH America LLC, are the property of those respective companies.



www.casece.com

 CASE IS A BRAND OF CNH,
A GLOBAL LEADER IN CONSTRUCTION EQUIPMENT, AGRICULTURAL EQUIPMENT AND FINANCIAL SERVICES.

Form No. CCE4210505
Replaces Form No. CCE4150318 0503

Printed in U.S.A.

© 2005 CNH America LLC
All Rights Reserved