



- Hydrostatic drive
- 16 horsepower
- 8 ft. hinge pin height
- 700 lbs. load rating
- 2029 lbs. operating weight

Model 1816 Uni-Loader

Loader Operational Data

Rated lift capacity —	
Mfr. rating	700 lbs. (318 kg)
Tipping load (S.A.E. rated)	1035 lbs. (469 kg)
Raising time with rated load in the bucket	8 sec.
Dumping time with rated load	2.4 sec.
Lowering time, bucket empty	3.7 sec.
Rollback time from full dump to full rollback	4 sec.
Travel speed, forward and reverse	0 to 4.8 mph (7.7 km/h)

Weights

Shipping weight of 1754 lbs. (796 kg) includes full fuel, no operator, no bucket, with 5.90 x 15 tires, ROPS and standard equipment.

Operating weight of 2029 lbs. (920 kg) includes full fuel, 175 lb. (79 kg) operator, 35" (889 mm) bucket, 5.90 x 15 tires, ROPS and standard equipment.

Unit shown is equipped with non-standard items. Manufactured by J I Case Company, Racine, Wisconsin, U.S.A.

J I Case



Specifications 1816 Uni-Loader

Engine

Make and model	Tecumseh, HH 160-170036
* Horsepower — U.S. (metric)	16.0 @ 3600 rpm 16.2 @ 3600 tr/mn
Bore and stroke	3 1/2" x 2 1/8" (89 mm x 73 mm)
Displacement	27.66 cu. in. (453 cm ³)
Number of cylinders	One
Cooling	Air cooled
Type of fuel	Regular gasoline
Fuel tank capacity	8.5 U.S. gallons (33 liters)
Engine crankcase oil	1.6 U.S. quarts (1.5 liters)
Air cleaner	Dry type, replaceable element
Electrical system	
Battery	12V 32 amp. hr.
Alternator, flywheel type	20 amp.
Starter	12V
Ignition	Solid state ignition unit without points.

*Per SAE J608 definition.

Power Train

Hydrostatic with drive chains to four wheels. Two variable displacement pumps. Two fixed displacement, high torque, low speed motors.

Hydraulic System

System relief pressure setting	1150 ± 50 psi @ 3600 rpm (81 ± 3.5 kg/cm ² @ 3600 tr/mn)
Lift cylinders (two)	2" dia. x 27" stroke, 1" rod (51 mm dia. x 686 mm stroke, 25 mm rod)
Tilt cylinders (two)	2" dia. x 13.1" stroke, 1" rod (51 mm dia. x 333 mm stroke, 25 mm rod)
Filter	25 micron, spin on type with by-pass valve and restriction indicator gauge.
Pump capacity	8 gpm @ 3600 rpm @ 1100 psi (30 liters/min. @ 3600 tr/mn @ 81 ± 3.5 kg/cm ²)
Capacities — total system Reservoir refill	7 US gallons (26 liters) 3.5 US gallons (13.2 liters)

Tires

Standard: 5.90 x 15, I-3 tread, 4PR, reversible
Optional: 5.70 x 15, chevron tread, 4PR, reversible
27 - 8.50 x 15, terra extra traction, 4PR, non-reversible.

Attachments

Buckets

Types	Width Inch (mm)	Struck Capacities cu. ft. (m ³)	SAE Heaped Capacities cu. ft. (m ³)	Weight lbs. (kg.)
Dirt utility	35" (889)	3.82 (0.11)	4.93 (0.14)	115 (52)
Dirt utility	44" (1118)	4.84 (0.14)	6.34 (0.18)	130 (59)
Light material	48" (1219)	8.72 (0.25)	11.35 (0.32)	172 (78)

Manure Fork

Number of tines	Seven
Width between each tine	5 1/2" (140 mm)
Overall width of tines	34 1/2" (876 mm)
Overall width of attachment	35 1/2" (902 mm)
Length of tine	19 1/4" (502 mm)
Weight	157 lbs. (71 kg)

Pallet Fork

Maximum width of forks	29" (737 mm)
Minimum width of forks	7 1/2" (191 mm)
Length of fork	30" (762 mm)
Overall width of attachment	34" (864 mm)
Weight	126 lbs. (57 kg)

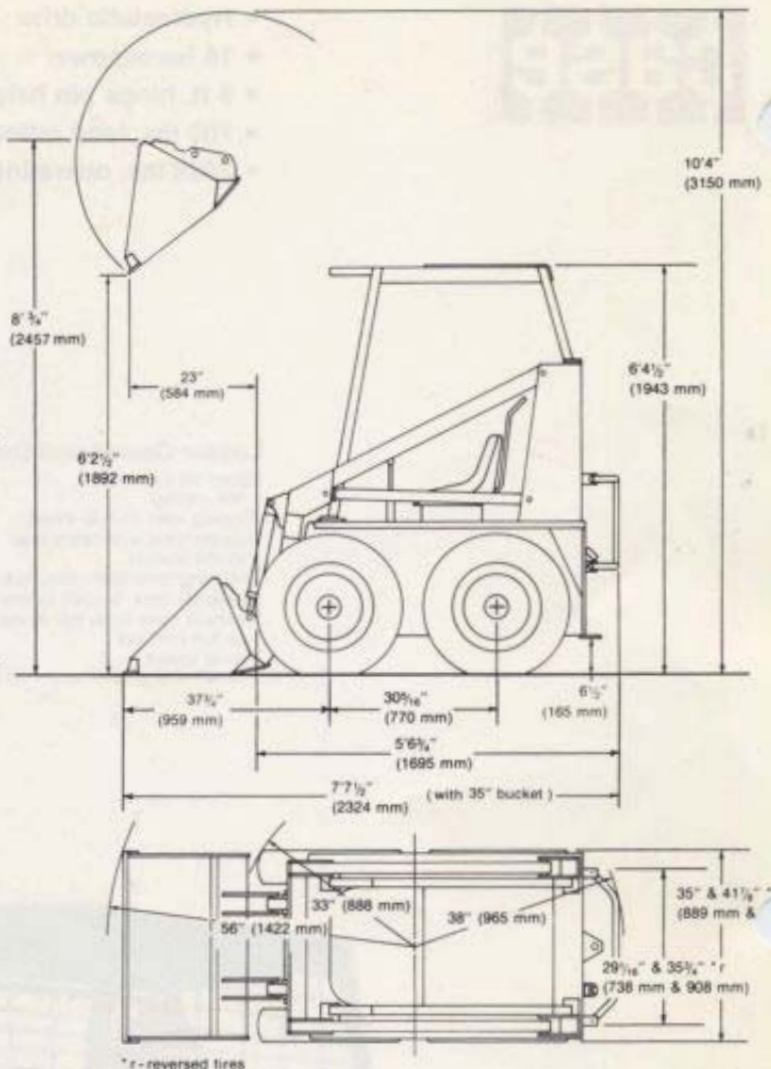

* r - reversed tires

Standard Equipment (on basic unit)

700 lb. (316 kg) loader lift capacity rating, with two double acting lift cylinders, less attachments, with controls and hydraulics. 16 hp Tecumseh air-cooled gasoline engine with fuel pump and solid state ignition system. Key switch starting. Enclosed flywheel alternator. 12V battery. Dry type air cleaner. Muffler, 8 gpm (30 liters/min.) hydraulic pump. Hydraulic oil filter with condition indicator and replaceable element. Ammeter. Transmission oil temperature gauge. Hand throttle. Hand choke. Hydrostatic transmission with permanently lubricated #60L chain drive to all wheels. Independent steering controls. Adjustable seat. Operator's compartment heat shield. Seat belt. Case ROPS. Non-directional lug tires.

Optional Equipment (on basic machine)

Chevron or "high flotation" type tires. Mechanical parking brake. Rear counterweights. Fabric ROPS enclosure. Auxiliary hydraulics.

Optional Equipment (attachments)

35" (889 mm), 44" (1118 mm), and 48" (1219 mm) buckets. Pallet fork. Manure fork. Manure fork grapple. Tool tach feature for front mounted equipment.

NOTE: Specifications, prices, standard equipment and optional equipment subject to change without notice.

Sold and serviced by: