

85XT Skid Steer



ENGINE

Model Case 4-390 diesel
Type..... 4-stroke, naturally aspirated
Cylinders..... 4
Bore/Stroke 4.02" x 4.72"
(102 x 120 mm)
Displacement..... 239 in³ (3.9 L)
Fuel injection..... Direct
Fuel #2 Diesel
Fuel filter..... In-line strainer
Air intake Cross-flow
Cooling Liquid
Engine speeds (rpm)
High idle - no load 2650±50
Rated - full load..... 2500
Low idle..... 950
Horsepower per SAE J1349
Gross..... 80 (59.7 kW) @ 2500 rpm
Net 69 (51.5 kW) @ 2500 rpm
Peak torque
@ 1200 rpm 193 lb-ft (262 N·m)

ENGINE COOLING

Radiator
Core type Square wave
serpentine
Core size area.... 165.9 in² (.107 m²)
Rows of tubes 5
Cap pressure 14.9 psi (103 kPa)
Fan
Diameter 20.4" (518 mm)
Ratio 1.1:1
Water pump
Style Integral
Flow..... 50.7 gpm (192 L/min)
Engine lubrication
Pump..... Deep sump plate cooler
with pressurized
under-piston nozzles
Pump operating angle ratings
Side-to-side..... Rated 45°
Fore and aft Rated 35°
Oil filtration Replaceable,
full-flow cartridge

POWERTRAIN

Drive pump Tandem, axial piston
hydrostatic transmission
driven directly off
engine flywheel
Pump to engine ratio 1:1
Displacement ... 0 to 3.11 in³ (51 cc)
Pump flow @ rated rpm... 33.7 gpm
(128 L/min)
Flow Bi-directional
Charge pressure.... 350 psi (24 bar)
System relief..... 4714 psi (325 bar)
Controls Servo
Drive motors Fixed displacement
high torque, low-speed gerotor
motor with shuttle valve
Maximum displacement.... 38.8 in³
(635 cc)
Speed @ rated engine rpm
@ max displacement..... 201 rpm
Torque @ max displacement
and relief pressure..... 2,422 lb-ft
(3284 N·m)
Travel speed 0 - 7.6 mph
(12.2 km/h)
Final drive..... Single-reduction
chain drive
Drive chain
Size ASA #100HS
Tensile strength 30,000 lb
(133,452 N)
Axles..... One-piece, forged
induction-hardened
high carbon steel
Torque @ rated rpm 5,302 lb-ft
(7189 N·m)
Diameter 2.5" (63.5 mm)
Length 14.76" (375 mm)
Parking brakes Spring-applied,
hydraulic release
Capacity 3,012 lb-ft (4083 N·m)
(per side at the axle)
Engagement Depress on/off
brake button at left-hand control
lever, raise seat bar, get off seat,
stop engine

HYDRAULIC SYSTEM

Standard equipment pump
Gear pump with integrated
constant pressure valve
Displacement .. 2.44 in³/rev (40 cc)
Pump flow @ rated engine rpm
Total 25.1 gpm (95 L/min)
To charge..... 4.8 gpm (18 L/min)
Flow 20.3 gpm (77 L/min)
Loader control valve 2-spool
open-center series with
power beyond port
Relief pressure .. 3002 psi (207 bar)
Port relief pressures
#1A Lower 3800 psi (262 bar)
#1B Raise..... 3800 psi (262 bar)
#2A Rollback 3800 psi (262 bar)
#2B Dump..... 3100 psi (214 bar)
Auxiliary valve... 1-spool open-center
Hydraulic lines
Tubing 2nd plated steel
Loop hoses SAE 100 R12
Swing-out hydraulic oil cooler
Core type Four row in-line
Hydraulic filters 2-micron charge,
6-micron return
spin-on replaceable elements
on the return and charge
lines with warning indicator
Filter capacity
Return line filter 0.95 oz (27 g)
Charge line filter 0.35 oz (10 g)

INSTRUMENTATION

Digital hourmeter
 Fuel level LED bar graph
 Warning lights
 Fuel level
 Voltage
 Engine coolant temperature
 Transmission charge pressure
 Engine oil pressure
 Air cleaner restriction
 Hydraulic filter restriction
 Engine oil pressure
 Parking brake
 Systems normal
 Seat belt reminder
 Warning alarms
 Engine coolant temperature
 Transmission charge pressure
 Engine oil pressure
 Hydraulic oil temperature
 Seat belt reminder

ELECTRICAL SYSTEM

Alternator..... 65 amp
 Starter 2.5 kW
 Battery 12-volt low-maintenance
 610 cold-cranking amps
 @ 0° F (-18 C)

OPERATOR ENVIRONMENT

No-tool tilt ROPS/FOPS canopy
 w/side screens
 Vinyl seat
 Seat presence switch
 2" (51 mm) retractable seat belt
 Restraint bar w/integral arm rests
 Two servo-assist, adjustable,
 hands-only control levers
 Hand and foot throttles
 Loader control lockout system
 In-cab loader arm lock
 Rear window w/escape provision
 Front and rear halogen floodlights
 Floor cleanout panel

CYLINDERS

Lift cylinder
 Bore diameter..... 2.5" (63.5 mm)
 Rod diameter 1.75" (44.4 mm)
 Stroke 41.3" (1.05 m)
 Closed length..... 53.03" (1.35 m)
 Bucket cylinder
 Bore diameter..... 2.75" (69.8 mm)
 Rod diameter 1.375" (34.9 mm)
 Stroke 20.67" (525 mm)
 Closed length..... 31.5" (800 mm)

OPERATING WEIGHTS

Unit equipped with 12.00 x 16.5
 Galaxy Beefy Baby tires, 73" (1.85 m)
 dirt bucket, mechanical attachment
 coupler, full fuel ... 8,057 lb (3655 kg)

Add-on weights
 Side cab glass +70 lb (32 kg)
 Lexan® door +70 lb (32 kg)
 Glass door w/wiper.... +77 lb (35 kg)
 Auxiliary high-flow +256 lb
 (116 kg)
 Heater +10 lb (4.5 kg)
 Suspension seat..... +10 lb (4.5 kg)
 Hydraulic attachment
 coupler +38 lb (17 kg)
 Counterweight +925 lb (420 kg)

SERVICE CAPACITIES

Fuel tank..... 17.3 gal (65.5 L)
 Engine oil w/filter 11 qt (10.4 L)
 Engine oil w/o filter..... 10 qt (9.5 L)
 Engine cooling system... 17.5 qt (16.6 L)
 Hydraulic system
 Reservoir 5.7 gal (21.7 L)
 Total 16.5 gal (62.5 L)
 Chain tanks (per side)..... 8 qt (7.6 L)

TIRE SELECTION

	Size	Ply Rating	Tread Depth	Tire Width	Width Over Tires	Tire Weight*	Max Travel Speed
Solideal Hauler SKS.....	12.00 x 16.5	10	0.75" (19 mm)	13.1" (333 mm)	72" (1.83 m)	51 lb (23.1 kg)	7.7 mph (12.4 km/h)
Galaxy Beefy Baby II.....	12.00 x 16.5	10	0.75" (19 mm)	12.3" (312 mm)	72" (1.83 m)	81 lb (36.7 kg)	7.7 mph (12.4 km/h)
Galaxy Hippo	33/15.50 x 16.5	12	0.81" (21 mm)	12.8" (325 mm)	80" (2.03 m)	96 lb (43.5 kg)	7.7 mph (12.4 km/h)
Galaxy King Kong.....	12.00 x 16.5	10	1.25" (32 mm)	10.2" (259 mm)	72" (1.83 m)	96 lb (43.5 kg)	7.8 mph (12.5 km/h)
Galaxy Hulk.....	12.00 x 16.5	12	0.81" (21 mm)	12.3" (312 mm)	72" (1.83 m)	100 lb (45.3 kg)	7.7 mph (12.4 km/h)
Galaxy Bulky Hulk.....	33/15.50 x 16.5	14	0.81" (21 mm)	16.7" (424 mm)	80" (2.03 m)	124 lb (56.2 kg)	7.7 mph (12.4 km/h)
Case Steel Tracks	12.00 x 16.5	NA	1.4"∞ (36 mm)	14.7"∞ (373 mm)	78" (1.98 m)	959 lb (435.0 kg)	8.1 mph (13.1 km/h)

NOTE: *Tire weight does not include wheel weight. ∞Equals grouser depth. ∅Equals track width.

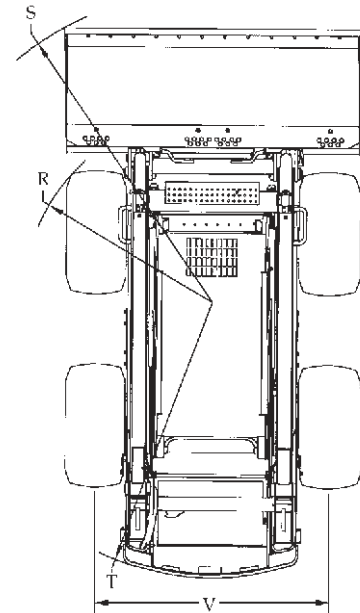
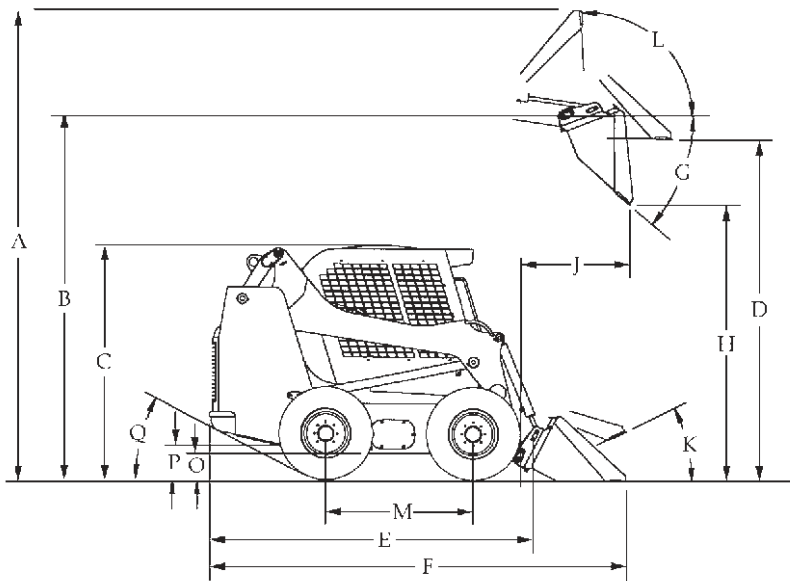

DIMENSIONS

- A. Overall operating height
 - Dirt bucket..... 159.6" (4.05 m)
 - Light material bucket..... 162.3" (4.12 m)
- Height to*
- B. Bucket hinge pin..... 122.4" (3.11 m)
- C. Top of rollover protective structure..... 80" (2.03 m)
- D. Bottom of level bucket, loader arm fully raised 114.6" (2.91 m)
- Overall length
- E. w/o attachment w/coupler 103.1" (2.62 m)
- F. w/dirt bucket on ground 135.5" (3.44 m)
- F. w/light material bucket on ground 143.2" (3.64 m)
- G. Dump angle at maximum height
 - Dirt bucket..... 40°
 - Light material bucket..... 35°
- H. Dump height – loader arm fully raised
 - Dirt bucket..... 92.3" (2.34 m)
 - Light material bucket..... 90.5" (2.30 m)
- J. Reach – loader arm fully raised
 - Dirt bucket..... 39.5" (1.0 m)
 - Light material bucket..... 47.9" (1.22 m)
- Maximum attachment rollback
- K. Bucket on ground..... 27°
- L. Bucket at full height..... 68°
- M. Wheelbase 44.9" (1.14 m)
- Ground clearance
- O. Bottom of chain case..... 9.1" (231 mm)
- P. Bottom of belly pan 11" (279 mm)
- P. Bottom of optional counterweight 9.1" (231 mm)
- Q. Angle of departure 28°
- Clearance circle front
- R. less bucket 53.9" (1.37 m)
- S. w/73" (1.85 m) dirt bucket on ground 83.8" (2.13 m)
- S. w/82" (2.08 m) dirt bucket on ground 85.8" (2.18 m)
- S. w/82" (2.08 m) light material bucket on ground 92.7" (2.35 m)
- T. Clearance circle rear 61.1" (1.55 m)
- V. Tread width, centerline to centerline 59.7" (1.52 m)

NOTE: *Equipped with 12.00 x 16.5 tires.

PERFORMANCE SPECS

- Operating load 2,400 lb (1089 kg)
- w/counterweight 2,860 lb (1297 kg)
- Tipping load..... 4,800 lb (2177 kg)
- w/counterweight 5,720 lb (2595 kg)
- Breakout force
 - Lift cylinder 4,936 lbf (21 956 N)
 - Bucket cylinder 6,175 lbf (27 468 N)
- Dig depth
 - w/bucket flat 0.24" (6 mm)
- Cycle time
 - Raise 4.1 seconds
 - Lower 3.0 seconds
 - Dump 2.5 seconds
 - Rollback 2.0 seconds

NOTE: SAE rated lift capacities. Cycle time measured with rated load in bucket.

OPTIONAL BUCKETS

Type	Width inch (m)	Weight lb (kg)	Capacity ft ³ (m ³)
Dirt.....	73.....	553.....	16.8
	(1.9)	(251)	(.48)
HD Dirt	82.....	593.....	19
	(2.1)	(269)	(.54)
Utility.....	73.....	621.....	16.8
	(1.9)	(282)	(.48)
HD Utility....	82.....	676.....	19
	(2.1)	(307)	(.54)
Light Material	73.....	628.....	22.4
	(1.9)	(285)	(.63)
.....	82.....	674.....	25.3
	(2.1)	(306)	(.72)
.....	73.....	696.....	22.4
	(1.9)	(316)	(.63)
.....	82.....	758.....	25.3
	(2.1)	(344)	(.72)

STANDARD EQUIPMENT

OPERATOR'S COMPARTMENT

ROPS/FOPS canopy w/side screens
No-tools tilt ROPS/FOPS
Instrument panels
Vinyl seat
2" (51 mm) retractable seat belt
Hand & foot throttles
Ergonomic hand controls
Restraint bar w/integral arm rests
Loader control lockout system
Fingertip brake control
Rear window w/escape provision
Floor cleanout panel

LOADER

Heavy lift-and-reach linkage
Mechanical attachment coupler

ENGINE

Case 4-390 diesel
Automatic fan belt tensioner
Integral engine oil cooling
Fuel filter w/water trap
Dual element air cleaner
65 amp alternator
610 CCA 12-volt battery
Heavy-duty radiator

POWERTRAIN

Hydrostatic four wheel drive
Servo controls
ASA #100HS drive chain
Disc parking brakes

HYDRAULICS

Auxiliary hydraulics 3000 psi
(207 bar) - 20.3 gpm (77 L/min),
hydraulic circuit pedal lock,
loader arm mounted ISO flat face
couplers
Loader function lockout system
Loader lift lockout override
2-spool loader control valve
1-spool auxiliary valve
Heavy-duty swing-out oil cooler
Loader arm float position

OTHER

Integral bumper counterweight
Heavy-duty louvered rear grille
Lockable service access hood
Single-point daily servicing
Halogen lights, 2-front, 1-rear
Rear tail lights and reflectors

OPTIONAL EQUIPMENT

OPERATOR'S COMPARTMENT

Vinyl suspension seat w/2"
(51 mm) retractable seat belt
Vinyl suspension seat w/3"
(76 mm) retractable seat belt
Auxiliary front electric controls
Chassis options harness
Lexan® front door
Glass front door w/wiper & washer
Sliding side windows
Heater (floor)
Heater (deluxe)
Accessory power outlet

LOADER

Ride Control
Hydraulic attachment coupler
Hydraulic two-way self-leveling

ENGINE

Coolant block heater
Thermostart

HYDRAULICS

Auxiliary high-flow
3000 psi (207 bar) - 38.3 gpm
(145 L/min)

OTHER

Backup alarm
Rotating beacon
925 lb (420 kg) counterweight
Lift hooks
Drawbar

OTHER (continued)

Horn
Special paint
Manual brake release
Buckets - see page 3
42"(1.07 m)/48"(1.22 m) pallet forks
Model 560 trencher
Model D125 backhoe
Bolt-on bucket cutting edges
Catalytic muffler
Aspirator
Battery disconnect switch
Automatic engine shutdown system
Steel tracks
ECI proportional fan drive
Tire options
Galaxy Poly Soft-Super Fill
Tyrllyner
Factory-installed tires - see page 2

NOTE: All specifications are stated in accordance with SAE Standards or Recommended Practices, where applicable.

Form No. CE 118-10-01
Replaces Form No. - CE 118-4-00



IMPORTANT: Case Corporation reserves the right to change these specifications without notice and without incurring any obligation relating to such change. Units shown may be equipped with non-standard equipment. Attachments from other manufacturers are shown for illustration only. Case Corporation does not warrant the safety or reliability of attachments from other manufacturers.

Visit Case Corporation on the Web at:
<http://www.casecorp.com>
Printed in U.S.A.

Lexan is a trademark of the General Electric Co.

Galaxy, Beefy Baby II, Hippo, Hulk, King Kong, Bulky Hulk, and Poly Soft-Super Fill are trademarks of the Galaxy Tire Co.

Hauler SKS is a trademark of Solideal Industrial Tires, Inc.

Tyrllyner is a registered trademark of Tyrllyner Company.

© 2001 CASE CORPORATION
All Rights Reserved. Case is a registered trademark of Case Corporation.

CASE CORPORATION
700 STATE STREET
RACINE, WI 53404 U.S.A.

CASE CANADA CORPORATION
450 SHERMAN AVENUE NORTH
HAMILTON, ON L8N 4C4 CANADA