



## ENGINE

Model	F5C E5454 C*A003
Emissions Certification	Tier 3
Type	Diesel 4-stroke, Turbo, D.I.
Cylinders	4
Bore/Stroke	3.9 x 4.1 in (99 x 104 mm)
Displacement	195 in <sup>3</sup> (3.2 L)
Fuel injection	Direct
Fuel	#2 Diesel
Fuel filter	In-line strainer
Oil filtration	Spin on – full-flow
Air intake	Turbocharged w/o waste gate
Cooling	Liquid
Engine speeds	RPM
High idle – no load	2675 +/- 75
Rated – full load	2500
Low idle	1075 +/- 75
Horsepower @ 2500 RPM – SAE J1349:	
Gross	90 hp (67 kW)
Net	84 hp (63 kW)
Peak torque @ 1400 RPM	251 lb-ft (340 N-m)
Radiator:	
Core type	All aluminum
Core size area	2.86 ft <sup>2</sup> (0.266 m <sup>2</sup> )
Rows of tubes x columns	44 x 4
Cap pressure	16 +/- 2 psi (1.10 +/- 0.14 bar)
Fan:	
Diameter	20.4 in (518 mm)
Ratio	0.96:1
Water pump:	
Style	Centrifugal
Flow	29 gpm (110 L/min)
Engine lubrication pump	Rotor pump w/ deep sump pan, plate cooler and pressurized under-piston nozzles
Pump operating angle ratings:	
Side to side	45°
Bucket up	35°
Bucket down	45°

## LIFT GEOMETRY

Radial Lift

## DRIVETRAIN

Drive pump controls	Mechanical
Pump to engine ratio	1:1
Displacement	2.81 in <sup>3</sup> (46 cm <sup>3</sup> )
Flow at rated engine RPM:	
@ 100% efficiency	29.4 gpm (111 L/min)
Charge pressure:	
	360 +/- 10 psi (24.5 +/- 0.5 bar)
System relief pressure	5,220 psi (360 bar)

Drive pump controls	Electro-hydraulic
Pump to engine ratio	1:1
Displacement	2.75 in <sup>3</sup> (46 cm <sup>3</sup> )
Flow @ rated engine RPM:	
@ 100% efficiency	28.8 gpm (109 L/min)
Charge pressure	362 psi (15 bar)
System relief pressure	5,220 psi (360 bar)

Drive motors:	
Max. displacement	28.7 in <sup>3</sup> (470 cm <sup>3</sup> )
Optional high speed	17.2 in <sup>3</sup> (282 cm <sup>3</sup> )
Speed @ high idle engine RPM	
100% efficiency at rated engine RPM	241
Speed @ optional high speed RPM	355
Torque @ max. displacement and relief pressure – calculated @ 5,003 psi (345 bar):	2,694 lb-ft (1 987 N-m)

Travel speed:	
Low range	7.0 mph (11.3 kph)
High range – optional	10.5 mph (16.9 kph)

Final drive	Single-reduction chain drive
-------------	------------------------------

Drive chain:	
Size	ASA #100
Tensile strength	30,000 lb (133.4 kN)

Axles:	
Torque @ max. displacement and relief pressure	6,623 lb-ft (8 980 N-m)
Diameter	2.44 in (61.9 mm)
Length	15.6 in (398.7 mm)

Parking brake:	
Type	Spring-applied, hydraulic release disc
Engagement	Depress on/off brake button on handle or instrument panel, raise seat bar, get off seat or stop engine

## ELECTRICAL

Alternator	120 amp
Starter	5.36 hp (4.0 kW)
Battery	12-volt low-maintenance 925 cold-cranking amps @ 0° F (-18° C°)

## OPERATOR ENVIRONMENT

Enclosed Cab w/ Heater and AC; Fully sealed and pressurized – FSP; Glass door w/ wiper and washer; Sliding side windows – removable; Heater and air conditioner; AM/FM radio w/ 2 speakers; Keyless start ignition; Tilt ROPS/FOPS;

Rear window w/ emergency escape; Deluxe cloth, air suspension seat, w/ 2 in (51 mm) retractable 3 point lap seat belt w/ heater and lumbar support; Hand and foot throttles; Alarm package – back-up and horn; Headliner; Dome Light; Top window; Cup holder; 12V Power plug socket; Foot rest; Seat pocket; Padded seat bar w/ integral armrests; Loader control lockout system; Electric parking brake control; Operator's compartment floor cleanout; Proportional auxiliary hydraulic control – on joystick; Advanced Instrument Cluster w/ digital hour meter, tachometer, Fuel level LCD bar graph w/ alarm, diagnostic features and security lockout.

Warning lights with alarms:  
Engine coolant temperature; Engine oil pressure; Engine malfunction; Hydraulic charge pressure; Hydraulic filter restriction; Hydraulic oil temperature: Critical system stop, Engine system, Hydraulic system, Electrical and diagnostic system.

Warning alarms:  
Battery voltage – plus display; Oil service.

Indicator light:  
Engine preheat; Parking brake;  
Seat bar reminder.

## OPERATING WEIGHT

Unit equipped w/ open cab; 165 lb operator; 72 in Low Profile bucket; full of fuel;	
12 x 16.5 tires:	7,700 lb (3 490 kg)
Shipping weight	7,365 lb (3 340 kg)

Add-on weights:	
Side cab glass	47 lb (21.3 kg)
Lexan® cab door	74 lb (33.6 kg)
Glass cab door w/ wiper	134 lb (60.8 kg)
Suspension seat	22 lb (10.0 kg)

## HYDRAULICS

Standard equipment pump type	Gear
Displacement:	
Standard aux.	2.08 in <sup>3</sup> (34.1 cm <sup>3</sup> )
High-flow aux.	1.1 in <sup>3</sup> (18.3 cm <sup>3</sup> )

Standard flow @ rated engine RPM: @ 100% efficiency	22.5 gpm (85 L/min)
--	---------------------

Optional high-flow @ rated engine RPM: @ 100% efficiency	34.6 gpm (131 L/min)
---	----------------------

Loader control valve:	
Type	3 spool/open center/series
Relief pressure	3,000 psi (207 bar)

Port relief pressures:	
Loader raise	3,263 psi (225 bar)
Bucket dump	3,770 psi (260 bar)
Bucket curl	1,160 psi (80 bar)

Hydraulic lines:	
Tubing	37° JIC Flare
Loop hoses	SAE 100 R13

## HYDRAULICS CONT.

Hydraulic oil cooler:	
Number of fins	10 per inch (3.94 per cm)
Number of tubes	11
Area	130.7 in <sup>2</sup> (843 cm <sup>2</sup> )

Hydraulic filter	6 micron/Spin-on
------------------	------------------

Lift cylinders:	
Bore diameter	2.50 in (63.5 mm)
Rod diameter	1.75 in (44.5 mm)
Stroke	32.2 in (817.9 mm)
Closed length	45.6 in (1 158.0 mm)

Bucket cylinders:	
Bore diameter	3.0 in (76.2 mm)
Rod diameter	1.5 in (38.1 mm)
Stroke	16.1 in (410.0 mm)
Closed length	24.0 in (610.0 mm)

## SERVICE CAPACITIES

Fuel tank	25.5 gal (96.5 L)
Engine oil w/ filter	2.5 gal (9.5 L)

Hydraulic system:	
Reservoir	6.9 gal (26.0 L)
Total	11.8 gal (44.5 L)
Chain tanks – per side	7.4 gal (27.9 L)

## PERFORMANCE SPECS

Rated operating load:	
50% of tipping load	2,500 lb (1 135 kg)
Tipping load	5,000 lb (2 270 kg)

Breakout forces @ 3,150 psi (217 bar):	
Bucket cylinder	7,480 lb (33.3 kN)
Lift cylinder – tip limit	5,680 lb (25.3 kN)

Cycle times:	
Raise	3.7 sec
Lower	1.9 sec
Dump	2.7 sec
Roll back	2.0 sec

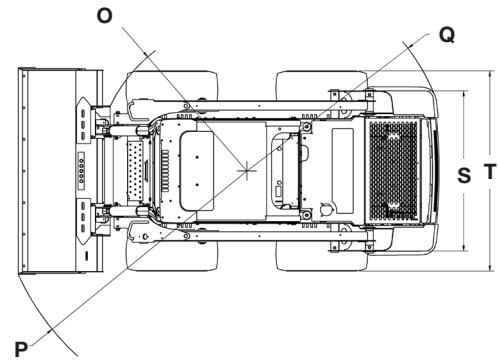
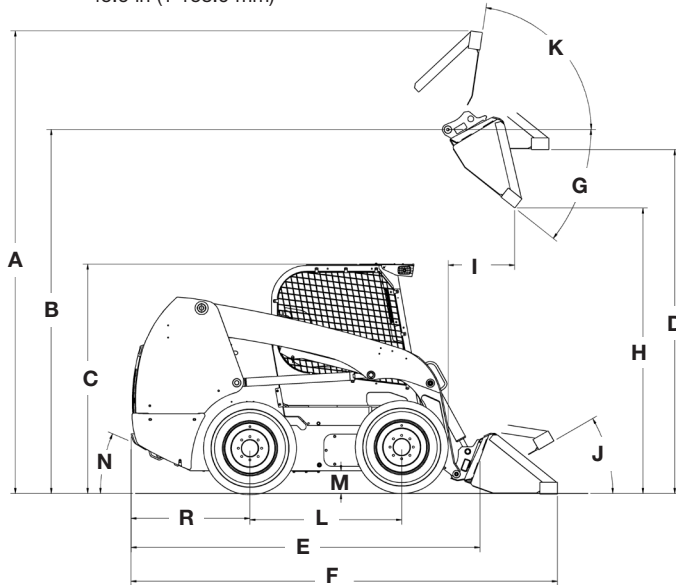

Line drawings are for illustrative purpose only and may not be exact representation of unit.

## DIMENSIONS

<b>A.</b> Overall operating height:		
with foundry/excavating bucket short lip		156.3 in (3.97 m)
with low profile/standard lip bucket		160.3 in (4.07 m)
with low profile extended/long lip bucket		165.3 in (4.20 m)
Height to:		
<b>B.</b> Bucket hinge pin		125.1 in (3.18 m)
<b>C.</b> Top of ROPS		78.8 in (2.00 m)
<b>D.</b> Bottom of level bucket, fully raised		123.3 in (3.12 m)
Overall length:		
<b>E.</b> without attachment with coupler		117.4 in (2.98 m)
<b>F.</b> with foundry/excavating bucket on ground		142.2 in (3.61 m)
with low profile bucket		146.2 in (3.71 m)
with low profile extended bucket		151.3 in (3.84 m)
<b>G.</b> Dump angle		38.1°
<b>H.</b> Dump height:		
with foundry/excavating bucket short lip	100.9 in (2 562 mm) @ 38.1°	
with low profile/standard lip bucket	98.3 in (2.50 m)	
<b>I.</b> Dump reach at maximum height		95.2 in (2.42 m)
Maximum attachment rollback:		
<b>J.</b> Bucket on ground		30.7°
<b>K.</b> Bucket at full height		99.7°
<b>L.</b> Wheelbase		52 in (1.32 m)
<b>M.</b> Ground clearance – bottom of belly pan		8.0 in (0.20 m)
<b>N.</b> Angle of departure		23.5°
Clearance circle:		
<b>O.</b> without bucket		55.1 in (1.40 m)
<b>P.</b> with 72 in (1.8 m) foundry bucket in carry position		83.5 in (2.12 m)
with 72 in (1.8 m) low profile bucket on ground		87.2 in (2.22 m)
with 72 in (1.8 m) extended low profile on ground		91.9 in (2.33 m)
<b>Q.</b> Clearance circle rear		70.4 in (1.79 m)
<b>R.</b> Rear axle to bumper		40.7 in (1.03 m)
Rolling radius		16.1 in (0.41 m)
<b>S.</b> Tread width with spec tires		56.9 in (1.45 m)
<b>T.</b> Over the tire width with spec tires		69.6 in (1.71 m)

**TIRE SELECTION**

Type	Size	Tread Gauge	Width Over Tires	Tire Weight
Heavy-Duty	12 x 16.5	57 in (1.47 m)	70 in (1.79 m)	—
Premium	12 x 16.5	57 in (1.47 m)	70 in (1.79 m)	—
Premium-Lined	12 x 16.5	57 in (1.47 m)	70 in (1.79 m)	—
Severe-Duty	12 x 16.5	57 in (1.47 m)	70 in (1.79 m)	—
Mining	12 x 16.5	57 in (1.47 m)	70 in (1.79 m)	—
Non-Pneumatic	12 x 16.5	57 in (1.47 m)	70 in (1.79 m)	—
Flotation	33 x 15.5	60 in (1.54 m)	76 in (1.93 m)	—
Premium	14 x 17.5	62 in (1.58 m)	76 in (1.93 m)	—

**OPTIONAL BUCKETS**

Type	Width	Weight	Heaped Capacity
Dirt & Foundry	72 in (1.83 m)	420 lb (190 kg)	16.2 ft <sup>3</sup> (0.46 m <sup>3</sup> )
	78 in (1.98 m)	440 lb (200 kg)	18.4 ft <sup>3</sup> (0.52 m <sup>3</sup> )
Low Profile	72 in (1.83 m)	420 lb (190 kg)	14.8 ft <sup>3</sup> (0.42 m <sup>3</sup> )
Low Profile Extended	72 in (1.83 m)	420 lb (190 kg)	17.7 ft <sup>3</sup> (0.50 m <sup>3</sup> )
	78 in (1.98 m)	440 lb (200 kg)	18.6 ft <sup>3</sup> (0.53 m <sup>3</sup> )
	84 in (2.13 m)	575 lb (262 kg)	20.2 ft <sup>3</sup> (0.57 m <sup>3</sup> )
Light Material	72 in (1.83 m)	420 lb (190 kg)	23.3 ft <sup>3</sup> (0.66 m <sup>3</sup> )
	84 in (2.13 m)	575 lb (262 kg)	27.9 ft <sup>3</sup> (0.79 m <sup>3</sup> )
Manure & Slurry	72 in (1.83 m)	420 lb (190 kg)	19.1 ft <sup>3</sup> (0.54 m <sup>3</sup> )
	84 in (2.13 m)	575 lb (262 kg)	22.5 ft <sup>3</sup> (0.64 m <sup>3</sup> )
Heavy-Duty	72 in (1.83 m)	420 lb (190 kg)	14.1 ft <sup>3</sup> (0.40 m <sup>3</sup> )
	78 in (1.98 m)	440 lb (200 kg)	15.9 ft <sup>3</sup> (0.45 m <sup>3</sup> )
	84 in (2.13 m)	575 lb (262 kg)	19.4 ft <sup>3</sup> (0.55 m <sup>3</sup> )

## STANDARD EQUIPMENT

### OPERATOR ENVIRONMENT

See page 1

### ENGINE

F5C E5454 C\*A003  
195 CID (3.2 L) Turbo  
Non-regulated  
Tier 3  
Turbocharged without waste gate fuel injection  
Horsepower:  
Gross: 90 hp (67 kW)  
Net: 84 hp (63 kW)  
Peak torque: 251 lb-ft (340 N·m)  
120 amp alternator  
Dual element air cooler  
Organic Acid Technology (OAT)  
Anti-freeze solution to -34° F  
Fuel tank - 25.5 gal (U.S.)  
Over and under radiator and oil cooler  
3-stack after cooler/radiator/oil cooler configuration  
Glow plugs

Integral engine oil cooler  
Fuel filter with water trap  
1,000 CCA 12V battery  
Master electrical disconnect

### DRIVETRAIN

2-speed hydrostatic four wheel drive  
ASA #100HS drive chain  
SAHR disc parking brake

### HYDRAULICS

Auxiliary hydraulics:  
@ 3,050 psi (210 bar) – 23.8 gpm (90 L/min)  
6 micron oil filtration system  
3-spool loader control valve  
Auxiliary hydraulic disconnects, ISO flat-face – connect-under-pressure with case drain  
Hydraulic circuit pedal lock  
Auxiliary function lockout override  
Loader lift lockout override  
Heavy-duty hydraulic oil cooler  
Loader arm float position  
Loader function lockout system  
Hydraulic one-way self-leveling  
Ride control

### LOADER

Heavy duty hydraulic attachment coupler  
Radial lift geometry  
Loader lift arm support strut  
SAE operating load: 2,500 lbs  
Tipping load: 5,000 lbs

### TIRES

12 X 16.5 Heavy duty

### OTHER STANDARD FEATURES

Halogen lights - 2 front, 2 side, 2 rear flood  
Heavy duty front lights  
Pre-wired for rotating beacon  
Lockable service access hood  
Single-point daily service  
Rear tail lights  
Remote oil drain  
Remote oil and fuel filters  
Block heater  
Debris ingress sealing  
Mounting points for add-on counterweights

## OPTIONAL EQUIPMENT

### OPERATOR ENVIRONMENT

ROPS/FOPS Level 1 canopy with side screens  
Keyed start ignition  
3-point seat belt  
Ventilation system with integrated heater  
Electro-hydraulic controls:  
For drive/steering, loader functions  
Switchable between H and ISO patterns  
Adjustable sensitivity of controls  
Mechanical hand controls  
Hand and foot controls:  
Hand controls the loader drive function and foot controls the bucket and boom  
Non suspension seat  
Suspension seat, vinyl  
Open cab interior trim package  
Demolition cab door with polycarbonate  
FOPS level 2  
Heavy duty rear door

### HYDRAULICS

High-flow auxiliary hydraulics – combined:  
@ 3,050 psi (210 bar) – 33.2 gpm (126 L/min)  
Second auxiliary hydraulics

### LOADER

Auxiliary front electric control  
Manual attachment coupler

### OTHER

Language decals  
Factory-installed tires – see page 3  
Buckets – see page 3  
Bolt-on bucket cutting edges  
Bolt-on heavy-duty bucket spill guard  
Special paint  
Offsite service arrangement  
Telematics

### FACTORY SUPPLIED ATTACHMENTS

Interior mirror  
Add-on counterweights  
Road lights  
Rotating beacon  
Four-corner LED strobe  
Bolt-on heavy-duty bucket teeth  
48 in (1.22 m) pallet forks

### SERVICE PARTS

3 inch (76.2 mm) retractable seat belt

CaseCE.com

©2016 CNH Industrial America LLC. All rights reserved. CASE is a trademark registered in the United States and many other countries, owned by or licensed to CNH Industrial N.V., its subsidiaries or affiliates. CNH Industrial Capital is a trademark in the United States and many other countries, owned by or licensed to CNH Industrial N.V., its subsidiaries or affiliates. Printed in U.S.A. Contains 10% post-consumer fiber.

IMPORTANT: CASE Construction Equipment Inc. reserves the right to change these specifications without notice and without incurring any obligation relating to such change. Availability of some models and equipment builds vary according to the country in which the equipment is used. The illustrations and text may include optional equipment and accessories and may not include all standard equipment. Your CASE dealer/distributor will be able to give you details of the products and their specifications available in your area.



CASE Construction Equipment is biodiesel-friendly. NOTE: All engines meet current EPA emissions regulations. All specifications are stated in accordance with SAE Standards or Recommended Practices, where applicable.



Always read the Operator's Manual before operating any equipment. Inspect equipment before using it, and be sure it is operating properly. Follow the product safety signs and use any safety features provided.

Form No. CCE201608SR250T3

Replaces Form No. CCE201604SR250T3

SR250

4 of 4