



## ENGINE

Model	N844LT-D-ROW
Emissions Certification	Tier 3/Tier 4 Interim
Type	Diesel 4-stroke, Turbo. I.D.I.
Cylinders	4
Bore/Stroke	3.31 x 3.94 in (84 x 100 mm)
Displacement	135.2 in <sup>3</sup> (2.2 L)
Fuel injection	Indirect
Fuel	#2 Diesel
Fuel filter	In-line strainer
Oil filtration	Replaceable, full-flow spin-on cartridge
Air intake	Turbocharged w/ Internal EGR
Cooling	Liquid
Engine speeds	RPM
High idle – no load	3140 +/- 40
Rated – full load	2800
Low idle	1200 +/- 50
Horsepower @ 2800 RPM – SAE J1349:	
Gross	60 hp (44.7 kW)
Net	57 hp (42.4 kW)
Peak torque @ 1800 RPM	126 lb-ft (171 N-m)
Radiator:	
Core type	All aluminum
Core size area	2.77 ft <sup>2</sup> (0.257 m <sup>2</sup> )
Rows of tubes x columns	43 x 3
Cap pressure	16 +/- 2 psi (1.10 +/- 0.14 bar)
Fan:	
Diameter	17.3 in (440 mm)
Ratio	1.1:1
Water pump:	
Style	Centrifugal
Flow	18.8 gpm (71.2 L/min)
Engine lubrication pump	Pressure feed w/ Trichoid pump, deep sump & plate cooler
Pump operating angle ratings:	
Side to side	35°
Bucket up	35°
Bucket Down	35°

## LIFT GEOMETRY

Vertical Lift

## DRIVETRAIN

Drive pump controls	Direct mechanical
Pump to engine ratio	1:1
Displacement	2.14 in <sup>3</sup> (35 cm <sup>3</sup> )
Flow @ rated engine RPM:	
@ 97% efficiency	25.9 gpm (98 L/min)
Charge pressure	360 psi (25 bar)
System relief pressure	5,000 psi (345 bar)

Drive pump controls	Electro-hydraulic
Pump to engine ratio	1:1
Displacement	2.14 in <sup>3</sup> (35 cm <sup>3</sup> )
Flow @ rated engine RPM:	
@ 97% efficiency	25.4 gpm (96 L/min)
Charge pressure	362 psi (25 bar)
System relief pressure	5,220 psi (360 bar)

Drive motors:	
Max. displacement	19.83 in <sup>3</sup> (325 cm <sup>3</sup> )
Optional high speed	12.2 in <sup>3</sup> (200 cm <sup>3</sup> )
Speed @ high idle engine RPM	
97% efficiency @ rated engine RPM	313
Speed @ optional high speed RPM	443
Torque @ max. displacement and relief pressure	1,315 lb-ft (1 783 N-m)

Travel speed:	
Low range	7.9 mph (12.7 kph)
High range – optional	11.2 mph (18.0 kph)

Final drive	Single-reduction chain drive
-------------	------------------------------

Drive chain:	
Size	ASA #80
Tensile strength	21,000 lb (93.4 kN)

Axles:	
Torque @ max. displacement and relief pressure	4,381 lb-ft (5 940 N-m)
Diameter	2.0 in (50.8 mm)
Length	15.1 in (384.0 mm)

Parking brake:	
Type	Spring-applied, hydraulic release disc
Engagement	Depress on/off brake button on handle or instrument panel, raise seat bar, get off seat or stop engine

## ELECTRICAL

Alternator	120 amp
Starter	2.95 hp (2.2 kW)
Battery	12-volt low-maintenance 925 cold-cranking amps @ 0° F (-18° C°)

## OPERATOR ENVIRONMENT

ROPS/FOPS Level 1 canopy w/ side screens; Keyed start ignition; Tilt ROPS/FOPS; Rear window w/ emergency escape; Suspension seat, vinyl w/ 2 in (51 mm) retractable 3 point lap seat belt; Hand and foot throttles; Alarm package – back-up and horn; Headliner; Dome Light; Top window; Cup holder; 12V Power plug socket;

Foot rest; Seat pocket; Padded seat bar w/ integral armrests; Loader control lockout system; Electric parking brake control; Operator's compartment floor cleanout; Proportional auxiliary hydraulic control – on joystick; Advanced Instrument Cluster w/ digital hour meter, tachometer, Fuel level LCD bar graph w/ alarm, diagnostic features and security lockout.

Warning lights with alarms:  
Engine coolant temperature; Engine oil pressure; Engine malfunction; Hydraulic charge pressure; Hydraulic filter restriction; Hydraulic oil temperature: Critical system stop, Engine system, Hydraulic system, Electrical and diagnostic system.

Warning alarms:  
Battery voltage – plus display; Oil service.

Indicator light:  
Engine preheat; Parking brake;  
Seat bar reminder.

## OPERATING WEIGHT

Unit equipped w/ open cab; 165 lb operator; 66 in Dirt & Foundry bucket; full of fuel;  
10 x 16.5 tires: 6,570 lb (2 980 kg)  
Shipping weight 6,270 lb (2 840 kg)

Add-on weights:  
Side cab glass 47 lb (21.3 kg)  
Lexan® cab door 74 lb (33.6 kg)  
Glass cab door w/ wiper 134 lb (60.8 kg)  
Suspension seat 22 lb (10.0 kg)

## HYDRAULICS

Standard equipment pump type	Gear
Displacement:	
Standard aux.	1.52 in <sup>3</sup> (24.9 cm <sup>3</sup> )
High-flow aux.	0.76 in <sup>3</sup> (12.5 cm <sup>3</sup> )

Standard flow @ rated engine RPM:  
@ 100% efficiency 19.1 gpm (72.0 L/min)

Optional high-flow @ rated engine RPM:  
@ 100% efficiency 28.7 gpm (109 L/min)

Loader control valve:	
Type	3 spool/open center/series
Relief pressure	3,000 psi (207 bar)

Port relief pressures:	
Loader raise	3,263 psi (225 bar)
Bucket dump	3,770 psi (260 bar)
Bucket curl	1,160 psi (80 bar)

Hydraulic lines:	
Tubing	37° JIC Flare
Loop hoses	SAE 100 R13

Hydraulic oil cooler:	
Number of fins	10 per inch (3.94 per cm)
Number of tube rows x columns	9 x 1
Area	137.5 in <sup>2</sup> (889 cm <sup>2</sup> )

Hydraulic filter	6 micron/Spin-on
------------------	------------------

## HYDRAULICS CONT.

<b>Lift cylinders:</b>	
Bore diameter	2.50 in (63.5 mm)
Rod diameter	1.75 in (44.45 mm)
Stroke	26.81 in (681 mm)
Closed length	38.66 in (982 mm)
<b>Bucket cylinders:</b>	
Bore diameter	2.50 in (63.5 mm)
Rod diameter	1.38 in (34.9 mm)
Stroke	16.14 in (410 mm)
Closed length	24.02 in (610 mm)

## SERVICE CAPACITIES

Fuel tank	20.0 gal (75.7 L)
Engine oil w/ filter	1.9 gal (7.1 L)
<b>Hydraulic system:</b>	
Reservoir	4.3 gal (16.3 L)
Total	10.0 gal (38.1 L)
Chain tanks – per side	2.0 gal (7.4 L)

## PERFORMANCE SPECS

<b>Rated operating load:</b>	
50% of tipping load	1,850 lb (840 kg)
Tipping load	3,700 lb (1 678 kg)
<b>Breakout forces:</b>	
Bucket cylinders	5,550 lb (24.7 kN)
Lift cylinders – tip limit	3,450 lb (15.3 kN)
Dig depth with bucket flat	0
<b>Cycle times:</b>	
Raise	3.7 sec
Lower	2.4 sec
Dump	2.2 sec
Roll back	1.6 sec

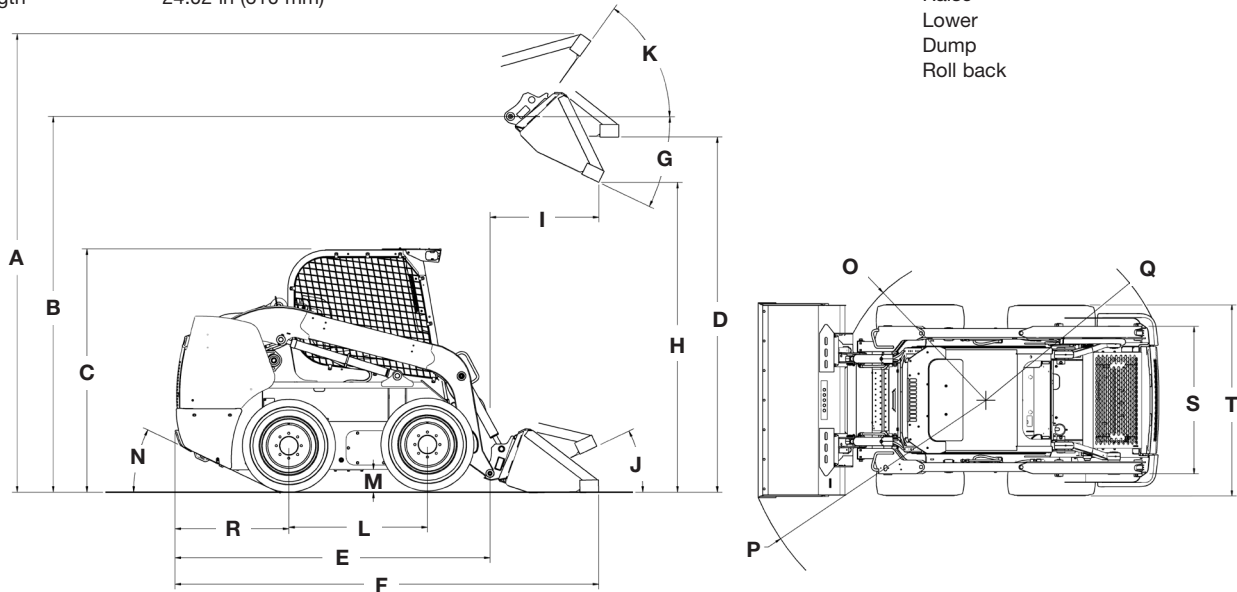

Line drawings are for illustrative purpose only and may not be exact representation of unit.

## DIMENSIONS

<b>A.</b> Overall operating height:	
with foundry/excavating bucket short lip	150.4 in (3.82 m)
with low profile/standard lip bucket	154.6 in (3.93 m)
with low profile extended/long lip bucket	159.6 in (4.05 m)
<b>Height to:</b>	
<b>B.</b> Bucket hinge pin	120.0 in (3.05 m)
<b>C.</b> Top of ROPS	77.7 in (1.97 m)
<b>D.</b> Bottom of level bucket, fully raised	113.3 in (2.88 m)
<b>Overall length:</b>	
<b>E.</b> without attachment with coupler	105.7 in (2.71 m)
<b>F.</b> with foundry/excavating bucket on ground	131.7 in (3.35 m)
with low profile bucket	135.8 in (3.45 m)
with low profile extended bucket	140.9 in (3.58 m)
<b>G.</b> Dump angle	51.9°
<b>H.</b> Dump height:	
with foundry/excavating bucket short lip	93.7 in (2.38 m)
with low profile/standard lip bucket	90.7 in (2.31 m)
with low profile extended bucket	87.2 in (2.21 m)
<b>I.</b> Dump reach at maximum height	30.8 in (0.78 m)
<b>Maximum attachment rollback:</b>	
<b>J.</b> Bucket on ground	35°
<b>K.</b> Bucket at full height	87.6°
<b>L.</b> Wheelbase	44.4 in (1.13 m)
<b>M.</b> Ground clearance – bottom of belly pan	7.0 in (0.18 m)
<b>N.</b> Angle of departure	
	23.0°
<b>Clearance circle:</b>	
<b>O.</b> without bucket	50.7 in (1.29 m)
<b>P.</b> with 66 in (1.68 m) foundry bucket in carry position	79.6 in (2.02 m)
with 66 in (1.68 m) low profile bucket on ground	83.9 in (2.13 m)
with 66 in (1.68 m) extended low profile on ground	88.6 in (2.25 m)
<b>Q.</b> Clearance circle rear	62.9 in (1.60 m)
<b>R.</b> Rear axle to bumper	36.4 in (0.92 m)
<b>S.</b> Tread width with spec tires	53.9 in (1.37 m)
<b>T.</b> Over the tire width with spec tires	66.1 in (1.68 m)

**TIRE SELECTION**

Type	Size	Tread Gauge	Width Over Tires	Tire Weight
Heavy-Duty	10 x 16.5	53.9 in (1.37 m)	64.6 in (1.68 m)	—
Premium	10 x 16.5	53.9 in (1.37 m)	64.6 in (1.68 m)	—
Premium-Lined	10 x 16.5	53.9 in (1.37 m)	64.6 in (1.68 m)	—
Severe-Duty	10 x 16.5	53.9 in (1.37 m)	64.6 in (1.68 m)	—
Non-Pneumatic	10 x 16.5	53.9 in (1.37 m)	64.6 in (1.68 m)	—
Heavy-Duty	12 x 16.5	57 in (1.47 m)	70 in (1.79 m)	—
Premium	12 x 16.5	57 in (1.47 m)	70 in (1.79 m)	—
Premium-Lined	12 x 16.5	57 in (1.47 m)	70 in (1.79 m)	—

**OPTIONAL BUCKETS**

Type	Width	Weight	Heaped Capacity
Dirt & Foundry	66 in (1.68 m)	440 lb (200 kg)	14.8 ft <sup>3</sup> (0.42 m <sup>3</sup> )
	72 in (1.83 m)	420 lb (190 kg)	16.2 ft <sup>3</sup> (0.46 m <sup>3</sup> )
	78 in (1.98 m)	440 lb (200 kg)	17.7 ft <sup>3</sup> (0.50 m <sup>3</sup> )
Low Profile	66 in (1.68 m)	470 lb (214 kg)	15.9 ft <sup>3</sup> (0.45 m <sup>3</sup> )
	72 in (1.83 m)	510 lb (232 kg)	17.7 ft <sup>3</sup> (0.50 m <sup>3</sup> )
Low Profile Extended	72 in (1.83 m)	510 lb (232 kg)	17.7 ft <sup>3</sup> (0.50 m <sup>3</sup> )
	78 in (1.98 m)	540 lb (245 kg)	19.1 ft <sup>3</sup> (0.54 m <sup>3</sup> )
	84 in (2.13 m)	575 lb (262 kg)	20.5 ft <sup>3</sup> (0.58 m <sup>3</sup> )
Light Material	72 in (1.83 m)	475 lb (216 kg)	23.3 ft <sup>3</sup> (0.66 m <sup>3</sup> )
	84 in (2.13 m)	540 lb (245 kg)	27.5 ft <sup>3</sup> (0.78 m <sup>3</sup> )
Manure & Slurry	72 in (1.83 m)	480 lb (218 kg)	19.1 ft <sup>3</sup> (0.54 m <sup>3</sup> )
	84 in (2.13 m)	545 lb (248 kg)	22.6 ft <sup>3</sup> (0.64 m <sup>3</sup> )
Heavy-Duty	66 in (1.68 m)	450 lb (205 kg)	13.1 ft <sup>3</sup> (0.37 m <sup>3</sup> )
	72 in (1.83 m)	585 lb (265 kg)	14.1 ft <sup>3</sup> (0.40 m <sup>3</sup> )
	78 in (1.98 m)	605 lb (275 kg)	15.5 ft <sup>3</sup> (0.44 m <sup>3</sup> )
Heavy-Duty with spillguard	66 in (1.68 m)	520 lb (235 kg)	16.6 ft <sup>3</sup> (0.47 m <sup>3</sup> )
	72 in (1.83 m)	585 lb (265 kg)	18.4 ft <sup>3</sup> (0.52 m <sup>3</sup> )
	78 in (1.98 m)	605 lb (275 kg)	19.8 ft <sup>3</sup> (0.56 m <sup>3</sup> )

## STANDARD EQUIPMENT

### OPERATOR ENVIRONMENT

See page 1

### ENGINE

N844LT-D-ROW  
135.2 CID (2.2 L) Turbo  
Non-regulated  
Tier 3/Tier 4 Interim  
Turbocharged with internal EGR fuel injection  
Horsepower:  
Gross: 60 (44.7 kW)  
Net: 57 (42.4 kW)  
Peak torque: 126 lb-ft (171 N·m)  
120 amp alternator  
Dual element air cleaner  
Organic Acid Technology (OAT)  
Anti-freeze solution to -34° F  
Fuel tank - 20 gal (U.S.)  
Over and under radiator and oil cooler  
3-stack after cooler/radiator/oil cooler configuration  
Glow plugs

Integral engine oil cooler  
Fuel filter with water trap  
925 CCA 12V battery  
Master electrical disconnect

### DRIVETRAIN

2-speed hydrostatic four wheel drive  
ASA #80HS drive chain  
SAHR disc parking brake

### HYDRAULICS

Auxiliary hydraulics:  
@ 3,050 psi (210 bar) – 23.8 gpm (90 L/min)  
6 micron oil filtration system  
3-spool loader control valve  
Auxiliary hydraulic disconnects, ISO flat-face – connect-under-pressure with case drain  
Hydraulic circuit pedal lock  
Auxiliary function lockout override  
Loader lift lockout override  
Heavy-duty hydraulic oil cooler  
Loader arm float position  
Loader function lockout system  
Hydraulic one-way self-leveling  
Ride control

### LOADER

Manual attachment coupler  
Vertical lift geometry  
Loader lift arm support strut  
SAE operating load: 1,850 lbs  
Tipping load: 3,700 lbs  
In-cab loader lock

### TIRES

10 X 16.5 Heavy duty

### OTHER STANDARD FEATURES

Halogen lights - 2 front, 2 side, 2 rear flood  
Heavy duty front lights  
Pre-wired for rotating beacon  
Lockable service access hood  
Single-point daily service  
Rear tail lights  
Remote oil drain  
Remote oil and fuel filters  
Block heater  
Debris ingress sealing  
Mounting points for add-on counterweights

## OPTIONAL EQUIPMENT

### OPERATOR ENVIRONMENT

Enclosed cab:  
Fully sealed and pressurized – FSP  
Glass door with wiper and washer  
Sliding side windows – removable  
Ventilation system with integrated heater  
Heater and air conditioner  
AM/FM radio with 2 speakers  
Keyless start ignition  
Electro-hydraulic controls:  
For drive/steering, loader functions  
Switchable between H and ISO patterns  
Adjustable sensitivity of controls  
Mechanical hand controls  
Hand and foot controls:  
Hand controls the loader drive function and foot controls the bucket and boom  
Non suspension seat  
Deluxe cloth, air suspension seat, with heater and lumbar support  
Open cab interior trim package  
Demolition cab door with polycarbonate  
FOPS level 2  
Heavy duty rear door

### HYDRAULICS

High-flow auxiliary hydraulics – combined:  
@ 3,050 psi (210 bar) – 33.2 gpm (126 L/min)  
Second auxiliary hydraulics

### LOADER

Auxiliary front electric control  
Hydraulic attachment coupler

### DRIVETRAIN

1-speed hydrostatic four wheel drive

### OTHER

Language decals  
Factory-installed tires – see page 3  
Buckets – see page 3  
Bolt-on bucket cutting edges  
Bolt-on heavy-duty bucket spill guard  
Special paint  
Offsite service arrangement  
Telematics

### FACTORY SUPPLIED ATTACHMENTS

Interior mirror  
Add-on counterweights  
Road lights  
Rotating beacon  
Four-corner LED strobe  
Bolt-on heavy-duty bucket teeth  
48 in (1.22 m) pallet forks

### SERVICE PARTS

3 inch (76.2 mm) retractable seat belt

## CaseCE.com

©2016 CNH Industrial America LLC. All rights reserved. CASE is a trademark registered in the United States and many other countries, owned by or licensed to CNH Industrial N.V., its subsidiaries or affiliates. CNH Industrial Capital is a trademark in the United States and many other countries, owned by or licensed to CNH Industrial N.V., its subsidiaries or affiliates. Printed in U.S.A. Contains 10% post-consumer fiber.

IMPORTANT: CASE Construction Equipment Inc. reserves the right to change these specifications without notice and without incurring any obligation relating to such change. Availability of some models and equipment builds vary according to the country in which the equipment is used. The illustrations and text may include optional equipment and accessories and may not include all standard equipment. Your CASE dealer/distributor will be able to give you details of the products and their specifications available in your area.



CASE Construction Equipment is biodiesel-friendly. NOTE: All engines meet current EPA emissions regulations. All specifications are stated in accordance with SAE Standards or Recommended Practices, where applicable.



Always read the Operator's Manual before operating any equipment. Inspect equipment before using it, and be sure it is operating properly. Follow the product safety signs and use any safety features provided.

Form No. CCE201608SV185T3

Replaces Form No. CCE201604SV185T3