

ENGINE

Model	Cummins QSM 11, Tier III Certified
Type	4-stroke, turbocharged
Cylinders	6
Bore/Stroke	4.92 in x 5.79 in (125 mm x 147 mm)
Displacement	660 in ³ (10.8 L)
Fuel injection	Electronic
Fuel	#2 Diesel
Fuel filter	Replaceable, full flow spin-on cartridge
Fuel cooler	
Air filter	Dry type element w/warning restriction indicator
Fan – Hydraulic drive – reversing	
Style	8 blade
Water pump	Integral
Engine oil	
Pump operating angles	
Side-to-side	45°
Fore and aft	45°
Oil filtration	Replaceable, full flow, spin-on cartridge
Engine speeds (rpm)	
Rated speed, full load	2200
Horsepower	
Peak	365 (272 kW) @ 1800 rpm
Rated	
Gross	335 (250 kW) @ 2200 rpm
Net	320 (239 kW) @ 2200 rpm
NOTE: Gross horsepower and torque per SAE J1995. Net horsepower and torque per SAE J1349.	
Torque – Peak	
	1,235 lb-ft (1674 N·m) @ 1400 rpm
Torque rise	
Standard power	40%

DRIVETRAIN

Transmission	4F/3R Proportional w/Electronic Control Module torque sensing autoshift/manual shift and modulation	
Gears	Helical cut	
Gear ratios	Forward	Reverse
1st	4.187	4.187
2nd	2.207	2.207
3rd	1.384	0.970
4th	0.608	NA
Torque converter		
Stall ratio	2.987:1	
Differential	Limited slip w/30% transfer on front w/45% transfer on rear axles	
Rear axle oscillation	26° total	
Front and rear axle		
Differential ratio	4.25	
Planetary ratio	6.35	
Final axle ratio	27.00	
Planetaries	Outboard	
Service brakes – outboard	Hydraulically actuated, shaft speed brakes and maintenance-free, multiple wet disc to all four wheels, w/accumulator for each axle	
Parking brakes	Spring-applied hydraulic release disc on transmission output shaft	
Travel speeds – mph (km/h) w/29.5 X 25 XHA Tires	Forward	Reverse
1st	3.9 (6.2)	3.9 (6.2)
2nd	7.1 (11.4)	7.1 (11.4)
3rd	10.9 (17.5)	14.7 (23.6)
4th	21.1 (34.0)	NA
NOTE: Travel speeds at full engine throttle.		

ELECTRICAL

Voltage	24 Volts, negative ground
Alternator	70 amp
Batteries	(2) 12 volt

HYDRAULICS

Hydraulic system	Open centered, tandem circuit system, pilot- operated controls
Vane pump	127 gpm @ 2000 rpm @ 2990 psi (482 L/min @ 2000 rpm @ 20 615 kPa)
Relief setting	2990 psi (20 615 kPa)
Steering system	Full hydraulic power steering, flow amplified, load sensing
Vane pump	71.3 gpm @ 2,000 rpm @ 2990 psi (270 L/min @ 2,000 rpm @ 20,615 kPa)
Loader control	Open center, sectional valve with pilot control for lift, tilt and auxiliary hydraulics, detent for float, raise and roll back

CYLINDERS

Lift cylinders	
Bore diameter	7.9 in (200 mm)
Rod diameter	4.3 in (110 mm)
Stroke	34.0 in (863 mm)
Dump cylinders	
Bore diameter	6.3 in (160 mm)
Rod diameter	3.1 in (80 mm)
Stroke	22.8 in (580 mm)

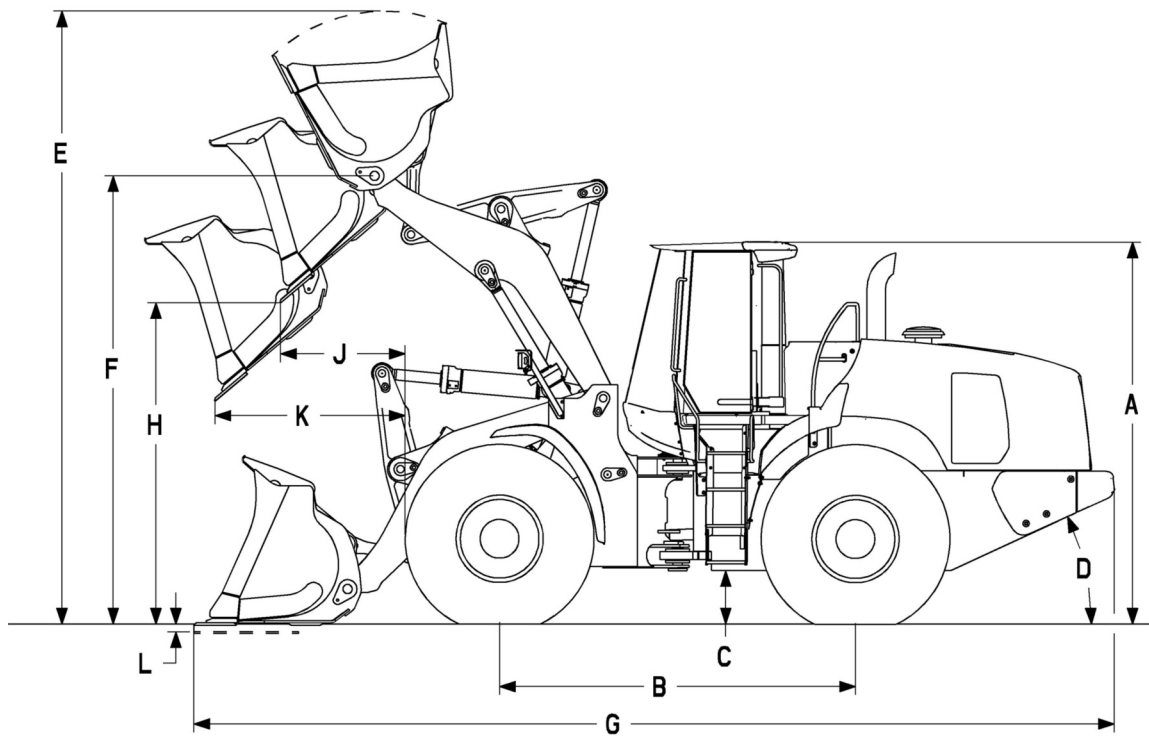

DIMENSIONS

Height to –		
A.	Top of ROPS cab	151 in (3.84 m)
	Drawbar	46 in (1.19 m)
B.	Wheelbase	146 in (3.70 m)
C.	Ground clearance	20 in (510 mm)
D.	Angle of departure	23°
Width –		
	Overall* w/o bucket (over tires)	128.9 in (3.27 m)
	Centerline tread	96 in (2.44 m)
	Turning radius* – outside	298.6 in (7.59 m)
Turning angle –		
	From center	40°
	Total angle	80°
	Rear axle oscillation, total	26°

NOTE: *Dimensions taken with 29.5 x 25 XHA tires. Additional dimensions on pages 3 and 4.

WEIGHT ADJUSTMENTS

Select Options	Weight Adjustment	Tipping Load Adjustment Straight	Tipping Load Adjustment 40° Turn
Full counterweight	240 lb (110 kg)	660 lb (300 kg)	550 lb (250 kg)

NOTE: **Unit equipped with Z-Bar loader arms, 7.6 yd³ (5.7 m³) general purpose pin on bucket, 29.5 x 25 XHA tires, ROPS cab with heater, counterweight, standard batteries, front and rear fenders, full fuel and 175 lb (79 kg) operator. Adjust select options from rated weight.

PERFORMANCE DATA

1221E Z-Bar

	9.2 yd ³ (7.0 m ³) Bucket w/Teeth & Segment	7.6 yd ³ (5.7 m ³) Bucket w/Bolt-on Edge	7.3 yd ³ (5.6 m ³) Bucket w/Teeth & Segment
SAE bucket capacity – struck	7.6 yd ³ (5.8 m ³)	6.5 yd ³ (5.0 m ³)	6.3 yd ³ (4.8 m ³)
Heaped	9.2 yd ³ (7.0 m ³)	7.6 yd ³ (5.7 m ³)	7.3 yd ³ (5.6 m ³)
Bucket width – outside	152.4 in (3.87 m)	135.8 in (3.45 m)	137.8 in (3.50 m)
Bucket weight	6,900 lb (3130 kg)	6,171 lb (2800 kg)	5,886 lb (2670 kg)
E. Operating height – fully raised w/spillguard	250.7 in (6.37 m)	249.0 in (6.34 m)	249.4 in (6.34 m)
F. Hinge pin height – fully raised	178.9 in (4.55 m)	179.0 in (4.55 m)	178.9 in (4.55 m)
G. Overall length – bucket level on ground	382.7 in (9.72 m)	382.0 in (9.69 m)	389.1 in (9.88 m)
Dump angle – fully raised	47°	47°	47°
H. Dump height – fully raised, 45° dump	126.4 in (3.21 m)	127.0 in (3.23 m)	121.4 in (3.08 m)
J. Bucket reach – fully raised, 45° dump	57.2 in (1.45 m)	56.0 in (1.43 m)	61.2 in (1.55 m)
K. Bucket reach – 7 ft 0 in (2.13 m) height, 45° dump	83.1 in (2.11 m)	82.5 in (2.10 m)	85.7 in (2.18 m)
Operating load – ISO	23,645 lb (10 725 kg)	24,041 lb (10 905 kg)	24,416 lb (11 075 kg)
Maximum material density – ISO	2,582 lb/yd ³ (1532 kg/m ³)	3,169 lb/yd ³ (1880 kg/m ³)	3,334 lb/yd ³ (1978 kg/m ³)
Tipping load – ISO			
Straight	55,060 lb (24 970 kg)	55,830 lb (25 320 kg)	56,660 lb (25 700 kg)
40° turn	47,300 lb (21 450 kg)	48,070 lb (21 810 kg)	48,840 lb (22 150 kg)
Lift capacity –			
Full height	27,620 lb (12 530 kg)	28,814 lb (13 070 kg)	28,590 lb (12 970 kg)
Maximum reach	45,990 lb (20 860 kg)	47,289 lb (21 450 kg)	47,110 lb (21 370 kg)
Ground	67,660 lb (30 690 kg)	69,864 lb (31 690 kg)	69,420 lb (31 490 kg)
Breakout force w/tilt cylinder	48,710 lb (22 090 kg)	49,710 lb (22 550 kg)	52,790 lb (23 950 kg)
Maximum rollback –			
Ground	41°	41°	41°
Carry position	47°	47°	47°
@ Maximum reach	63°	63°	63°
@ Full height	63°	63°	63°
L. Dig depth	2.4 in (60 mm)	2.4 in (60 mm)	0.9 in (22 mm)
Maximum grading angle w/bucket – back dragging	61.0°	60.9°	61.9°
Loader clearance circle	616.5 in (15.66 m)	600.0 in (15.25 m)	607.1 in (15.42 m)

NOTE: Performance data unit equipped with 29.5 x 25 XHA tires, ROPS cab w/heater and A/C, standard counterweight, standard batteries, wide front and rear fenders, full fuel and 175 lb (79 kg) operator. Specifications per SAE J732, J1234, J695, J742, and J818.

1221E XR

	9.2 yd ³ (7.0 m ³) Bucket w/Teeth & Segment	7.6 yd ³ (5.7 m ³) Bucket w/Bolt-on Edge	7.3 yd ³ (5.6 m ³) Bucket w/Teeth & Segment
E. Operating height – fully raised w/spillguard	267.5 in (6.80 m)	266.3 in (6.76 m)	266.3 in (6.76 m)
F. Hinge pin height – fully raised	195.0 in (4.96 m)	195.0 in (4.96 m)	195.0 in (4.96 m)
G. Overall length – bucket level on ground	400.6 in (10.18 m)	399.5 in (10.15 m)	407.0 in (10.34 m)
Dump angle – fully raised	47°	47°	47°
H. Dump height – fully raised, 45° dump	143.2 in (3.64 m)	144.0 in (3.66 m)	138.2 in (3.51 m)
J. Bucket reach – fully raised, 45° dump	59.6 in (1.51 m)	58.7 in (1.49 m)	63.9 in (1.62 m)
K. Bucket reach – 7 ft 0 in (2.13 m) height, 45° dump	97.9 in (2.48 m)	97.2 in (2.47 m)	100.6 in (2.56 m)
Operating load – ISO	20,117 lb (9125 kg)	20,492 lb (9295 kg)	20,823 lb (9445 kg)
Maximum material density – ISO	2,198 lb/yd ³ (1304 kg/m ³)	2,702 lb/yd ³ (1603 kg/m ³)	2,842 lb/yd ³ (1687 kg/m ³)
Tipping load – ISO			
Straight	46,720 lb (21 190 kg)	47,470 lb (21 530 kg)	48,180 lb (21 860 kg)
40° turn	40,230 lb (18 250 kg)	40,990 lb (18 590 kg)	41,650 lb (18 890 kg)
Lift capacity –			
Full height	26,410 lb (11 980 kg)	27,120 lb (12 300 kg)	27,310 lb (12 390 kg)
Maximum reach	42,280 lb (19 180 kg)	42,990 lb (19 500 kg)	43,360 lb (19 670 kg)
Ground	56,840 lb (25 780 kg)	57,670 lb (26 160 kg)	58,420 lb (26 500 kg)
Bucket force w/ tilt cylinder	47,270 lb (21 440 kg)	48,240 lb (21 880 kg)	51,230 lb (23 240 kg)
Loader clearance circle	632.3 in (16.06 m)	616.5 in (15.66 m)	623.2 in (15.83 m)

PERFORMANCE DATA

1221E Z-Bar

	6.7 yd ³ (5.1 m ³) Bucket w/Bolt-on Edge	6.3 yd ³ (4.8 m ³) Bucket w/Teeth & Segments
SAE bucket capacity – struck	5.6 yd ³ (4.3 m ³)	5.4 yd ³ (4.1 m ³)
Heaped	6.7 yd ³ (5.1 m ³)	6.3 yd ³ (4.8 m ³)
Bucket width – outside	135.8 in (3.45 m)	137.8 in (3.50 m)
Bucket weight	5,709 lb (2590 kg)	5,423 lb (2460 kg)
E. Operating height – fully raised w/spillguard	244.0 in (6.20 m)	244.1 in (6.20 m)
F. Hinge pin height – fully raised	178.7 in (4.54 m)	178.9 in (4.55 m)
G. Overall length – bucket level on ground	376.4 in (9.56 m)	384.0 in (9.75 m)
Dump angle – fully raised	47°	47°
H. Dump height – fully raised, 45° dump	130.9 in (3.33 m)	124.9 in (3.17 m)
J. Bucket reach – fully raised, 45° dump	52.8 in (1.34 m)	57.5 in (1.46 m)
K. Bucket reach – 7 ft 0 in (2.13 m) height, 45° dump	80.7 in (2.05 m)	83.6 in (2.12 m)
Operating load – ISO	24,339 lb (11 040 kg)	24,747 lb (11 225 kg)
Maximum material density – ISO	3,649 lb/yd ³ (2165 kg/m ³)	3,942 lb/yd ³ (2339 kg/m ³)
Tipping load – ISO		
Straight	56,460 lb (25 610 kg)	57,360 lb (26 020 kg)
40° turn	48,678 lb (22 080 kg)	49,500 lb (22 450 kg)
Lift capacity –		
Full height	28,775 lb (13 052 kg)	29,010 lb (13 160 kg)
Maximum reach	47,263 lb (21 438 kg)	47,580 lb (21 580 kg)
Ground	69,849 lb (31 683 kg)	70,770 lb (32 100 kg)
Breakout force w/tilt cylinder	54,584 lb (24 759 kg)	58,330 lb (26 450 kg)
Maximum rollback –		
Ground	41°	41°
Carry position	47°	47°
@ Maximum reach	63°	63°
@ Full height	63°	63°
L. Dig depth	2.4 in (60 mm)	0.9 in (22 mm)
Maximum grading angle w/bucket – back dragging	60.7°	61.2°
Loader clearance circle	597.0 in (15.17 m)	603.9 in (15.34 m)

1221E XR

	6.7 yd ³ (5.1 m ³) Bucket w/Bolt-on Edge	6.7 yd ³ (4.8 m ³) Bucket w/Bolt-on Edge
E. Operating height – fully raised w/spillguard	261.0 in (6.63 m)	261.0 in (6.63 m)
F. Hinge pin height – fully raised	195.0 in (4.96 m)	195.0 in (4.96 m)
G. Overall length – bucket level on ground	394.3 in (10.02 m)	402.0 in (10.21 m)
Dump angle – fully raised	47°	47°
H. Dump height – fully raised, 45° dump	147.6 in (3.75 m)	141.7 in (3.60 m)
J. Bucket reach – fully raised, 45° dump	55.1 in (1.40 m)	60.2 in (1.53 m)
K. Bucket reach – 7 ft 0 in (2.13 m) height, 45° dump	95.2 in (2.42 m)	98.3 in (2.50 m)
Operating load – ISO	20,779 lb (9425 kg)	21,109 lb (9575 kg)
Maximum material density – ISO	3,114 lb/yd ³ (1848 kg/m ³)	3,362 lb/yd ³ (1994 kg/m ³)
Tipping load – ISO		
Straight	48,060 lb (21 800 kg)	48,770 lb (22 120 kg)
40° turn	41,560 lb (18 850 kg)	42,220 lb (19 150 kg)
Lift capacity –		
Full height	27,580 lb (12 510 kg)	27,510 lb (12 480 kg)
Maximum reach	43,250 lb (19 740 kg)	43,540 lb (19 750 kg)
Ground	58,800 lb (26 670 kg)	59,260 lb (25 680 kg)
Bucket force w/tilt cylinder	52,970 lb (24 030 kg)	56,610 lb (25 680 kg)
Loader clearance circle	613.0 in (15.57 m)	620.1 in (15.75 m)

INSTRUMENTATION

Electronic Information Center

Displays/Gauges –
Speedometer
Tachometer
Direction selected F/N/R
Transmission modes – Auto shift/Manual shift
Gear position
Engine coolant temperature
Fuel level
Transmission oil temperature
Hydraulic oil temperature
Hourmeter
Battery voltmeter
Ride control status
Reversing fan - on

Indicator lights –
Low fuel
Turn signals
High beam lights
Brake pressure
Master indicator
Auxiliary steering*
Parking brake
Hydraulic oil temperature
Battery charging
Seat belt
Air cleaner restriction
Pre-heater
Brake warning
Engine oil pressure
Engine high temperature
Transmission de - clutch
Steering warning - Primary
Steering warning - Secondary

Audible alarms –
Caution alarm
Critical alarm
Backup alarm

Horn

NOTE: *If equipped with option.

OPERATOR ENVIRONMENT

ROPS cab w/ heat

Key start

Articulated power steering w/tilt column
--

Fully adjustable, suspension seat

Foot throttle

Single lever 2-spool loader control w/wrist rest
--

Cup holder

(2) Interior rearview mirror

2 in (51 mm) retractable seat belt

Storage tray

Single brake pedal

F/N/R shuttle switch

External rear view mirrors

Pressurized air filtering

Anti-glare window strip

Defroster

Side window, partial/fully open

Dome light

Wipers, rear and intermittent front

Windshield washers, front and rear

Rubber floor mat

Sunscreen

12V Power outlet

LOADER

Z-bar loader linkage

Single control for lift and tilt

Positive hold float

Automatic return-to-dig

Automatic height control

Brake pedal transmission disconnect

CYCLE TIME

Raise w/rated bucket load	6.4 sec
---------------------------	---------

Dump w/rated bucket load	1.4 sec
--------------------------	---------

Lower (empty)	
Power down	3.5 sec
Float down	3.0 sec

SERVICE CAPACITIES

Fuel tank	124.2 gal (470 L)
-----------	-------------------

Hydraulic system	
Total	89.8 gal (340 L)
Reservoir	55.4 gal (210 L)

Transmission	
Service w/filter	11.4 gal (43 L)

Front and rear axle w/o coolers	
Front	15.9 gal (60 L)
Rear	15.9 gal (60 L)

Engine oil w/filter	9.8 gal (37 L)
---------------------	----------------

Cooling system	17.2 gal (65 L)
----------------	-----------------

OPERATING WEIGHTS

Z-Bar

Unit equipped with ROPS cab with heater and A/C, counterweight, 29.5 x 25 XHA tires, wide front and rear fenders, 7.6 yd³ (5.7 m³) general purpose loader bucket, full fuel, 175 lb (79 kg) operator

66,930 lb (30 360 kg)

XR

Unit equipped with ROPS cab with heater and A/C, counterweight, 29.5 x 25 XHA tires, wide front and rear fenders, 6.7 yd³ (5.1 m³) general purpose loader bucket, full fuel, 175 lb (79 kg) operator

67,020 lb (30 400 kg)

STANDARD EQUIPMENT

OPERATOR ENVIRONMENT

See page 5

ENGINE

Cummins QSM 11
Tier III certified
Turbocharger
Charge air cooling
Automatic fan belt tensioner
Integral engine oil cooling
Fuel filter w/water trap
Dual element air cleaner
70 amp alternator
(2) 1000 CCA 12-volt batteries
Liquid-cooled radiator
Non spark-arresting muffler
Grid heater
Fuel heater

LOADER

See page 5

DRIVETRAIN

4-wheel drive
Axle coolers
4F/3R Selectable autoshift/manual shift transmission
Electronic Control Module – Programmable, computer controlled proportional shifting with programmable gear selection
Onboard diagnostics
Single lever electronic shift control
F/N/R switch in loader control handle
Downshift button
Torque converter
Outboard planetary axles
Limited-slip differentials
Transmission oil cooler
Brake pedal transmission disconnect
Hydraulic wet disc brakes
Spring-applied hydraulic release parking brake
Limp-Home Mode
Lubed-for-life drive shaft

HYDRAULICS

3-spool joystick and auxiliary control lever
Low-effort steering
Hydraulic driven fan
Reversing fan
Temperature controlled
(8) Diagnostic quick couplers

OTHER

Electric hood lift
Front and rear fenders
Lights –
(2) Front driving headlights (high/low beam)
(2) Front flood
(2) Stop/tail lights
(2) Rear flood
Front and rear turn signal/flash
Standard counterweight
Drawbar hitch
Articulation locking bar
Lift and tie-down points – front/rear
Backup alarm
RH steps and platform

OPTIONAL EQUIPMENT

OPERATOR COMPARTMENT

Heated, cloth-covered air-suspension seat
Cab air-conditioning w/heater
CD player
Sliding side cab window
Fire extinguisher
(2) Cab lights front
(2) Cab lights rear
Rotating beacon
Second brake pedal

ENGINE

Cold weather package
Heavy-duty batteries
Fuel heater
Hydraulic oil cooler bypass
Low temperature hydraulic oil
Ether

LOADER

XR configuration

HYDRAULICS

Ride Control
Secondary steering
3-spool loader valve with 3-lever loader control

TIRES

26.5 x 25 L3 Bias
29.5 R25 L5 Bias
29.5 R25 Radial

OTHER

Heated outside mirrors
Tool box
Sound Shield noise suppression package
Full counterweight

NOTE: All specifications are stated in accordance with SAE Standards or Recommended Practices, where applicable.

NOTE: All engines meet current EPA emissions requirements.

IMPORTANT: Case Construction Equipment Inc. reserves the right to change these specifications without notice and without incurring any obligation relating to such change. Case Construction Equipment Inc. does not warrant the safety or reliability of attachments from other manufacturers.

Case is a registered trademark of CNH America LLC. Any trademarks referred to herein, in association with goods and/or services of companies other than CNH America LLC, are the property of those respective companies.



www.casece.com