

Wheel Loader

170 net horsepower (126.8 kW)

Buckets up to 4 yd³ (3.1 m³)

SAE breakout force 38,713 lbf (172.2 kN)

821



case

821

821 Basic Tractor

Engine

Make and model **Case 6T-830**
 Type of fuel No. 2 diesel
 No. of cylinders 6
 Bore and stroke 4.48" x 5.32"
 (114 mm x 135 mm)
 Displacement 505 in³ (8.30 L)
 Compression ratio 17.3 to 1
 Fuel induction Open chamber
 direct injection
 Fuel supply Injection pump
 Air cleaner Dry type elements with
 warning restriction indicator
 Oil filter Spin-on replaceable
 cartridge
 Lubrication Positive pressure
 Cooling system Air/water with lube
 oil cooler

Horsepower
 (1) SAE gross 187 @ 2000 rpm
 (139.4 kW @ 2000 r/min)
 (2) SAE net 170 @ 2000 rpm
 (126.8 kW @ 2000 r/min)
 Governed speed 2200 rpm
 Max torque — lbf-ft
 (1) SAE gross 570 @ 1500 rpm
 (772.4 Nm @ 1500 r/min)
 (2) SAE net 543 @ 1500 rpm
 (735.8 Nm @ 1500 r/min)

(1) Gross engine horsepower and torque at flywheel per SAE Standard J1349
 (2) Net engine horsepower and torque at flywheel per SAE Standard J1349

Electrical

System voltage 24 volts,
 negative ground
 Batteries (2) 12 volt, low maintenance
 600 cold cranking amps
 0°F (-18°C)
 Alternator 65 amperes

Travel Speeds — mph (km/h)

Engine at full throttle - 20.5 x 25 tires

	1st	2nd	3rd	4th
Forward	4.0 (6.4)	6.8 (10.9)	14.4 (23.2)	25.2 (40.6)
Reverse	4.0 (6.4)	6.8 (10.9)	14.4 (23.2)	—

Power Train

Transmission: 4 speeds forward,
 3 reverse powershift. Forward/reverse
 modulated clutching in 1st and 2nd gears.

Torque converter: Single stage integral
 with transmission, 3.06 to 1 stall ratio.

Brakes

Air-over-hydraulic, 4-wheel, caliper disc
 service brakes. Two brake pedals: left pedal
 applies brakes and electrically interrupts
 power flow to drive wheels; right pedal applies
 brakes only. Two master cylinders for front-
 and-rear split system.

Manually applied drum parking brake
 on transmission output shaft electrically
 interrupts power flow to drive wheels when
 applied.

Axles

Outboard planetary. Torque-proportioning
 differentials. Front axle fixed; rear axle
 oscillates 24° total or 15.4" (391 mm) in each
 direction.

Steering

Center pivot articulated design with hydro-
 static power steering. Front and rear
 wheels always track. Two hydraulic cylinders
 controlled by a hydrostatic steering gear with
 relief and flow control valve.

Steering angle —
 each direction from center 40°

Pump . . . Transmission mounted, positive
 displacement, tandem, gear-type

Pump capacity —
 47.3 gpm @ 2200 rpm @ 2650 psi
 (179 L/min @ 2200 r/min @ 18 271 kPa)

System relief pressure —
 2650 psi (18 271 kPa)

Steering cylinders, (double-acting)
 (2) 3.50" dia x 17.14" stroke, 1.75" rod

(89 mm dia x 435 mm stroke, 44 mm rod)

Turning ratio, stop to stop 4 turns
 Turning radius,
 outside tires 18'9" (5.71 m)

Loader Hydraulic System

Cylinders: Double-acting, bolted gland with
 hardened and chrome-plated rods

Lift (2) . . . 6" dia x 31.75" stroke, 3" rod
 (152 mm dia x 806 mm stroke, 76 mm rod)

Tilt (1) . . . 7" dia x 22.78" stroke, 3.5" rod
 (178 mm dia x 579 mm stroke, 89 mm rod)

Pump: Transmission mounted, positive
 displacement, tandem, gear-type.

Pump capacity (total both sections)
 77.5 gpm (293 L/min) @ 2200 rpm

Relief valve setting . . 2650 psi (18 271 kPa)

Control valve: Open-center, series-parallel
 circuit, positive low-pressure regeneration for
 bucket dump.

Hydraulic lines: steel tubing with SAE fittings
 and wire-braid, high-pressure hose with
 swaged fittings.

Reservoir: Positive pressure on hydraulic
 reservoir; sealed for dirt exclusion.

Filtration: Full-flow, 10-micron, spin-on,
 replaceable filters in return line.

Hydraulic cycle time:

	Seconds
Raise (with rated bucket load)	6.2
Lower (empty, power down)	4.3
Lower (empty, float down)	3.8
Dump	1.6

Service Capacities

	U.S. Gal	Liters
Cooling system	8.5	32.2
Fuel tank	72	272.7
Engine		
crankcase only	4.8	18
crankcase and filter	5.2	19.8
Transmission and		
torque converter	6	22.7
Total in system	7.0	26.5
Service (w/filter)	3.25	12.3
Axles (front and rear)		
total	7.0	26.5
differential	4.6	17.4
each hub	1.2	4.5
Hydraulic System		
total	46	174.2
reservoir only	39.8	150.8

Standard Equipment

Air cleaner, two element dry type • Alternator
 with voltage regulator • Antifreeze to
 -34°F (-36°C) • Articulation lock • Axles,
 four wheel drive with torque proportioning •
 Backup alarm • Batteries, two 12 volt • Brake,
 parking • Brakes, four wheel disc • Bucket
 position indicator • Systems Monitor, four level
 warning • Differentials, torque proportioning
 • Engine side doors • Engine, industrial diesel
 • Fan guard • Fan, pusher • Fuel filter, dual
 • Fuse and circuit breaker (automatic)
 protected 24 volt electrical circuits • Gauges,
 (LCD type): engine coolant temperature, fuel
 level • Grab handles • Horn • Hour meter •
 Hydraulic oil cooler • Hydraulics, two spool
 • Lights, 2 front & 2 rear halogen floods, 2 rear
 stop • Loader controls, hydraulic servo type
 with detent activation switch • Loader linkage,
 sealed • ROPS canopy • Rear fenders •
 Return to dig, automatic • Seat, bucket type
 • Seatbelt, 2" (51 mm) anticreep • Starter,
 electric • Steering column, tilting •
 Transmission disconnect switch •
 Transmission oil cooler • Transmission, electric
 powershift • Warning lights (LED type):
 alternator, engine oil pressure, air pressure,
 work lights, air filter restriction, hydraulic filter
 restriction, hydraulic temperature, transmis-
 sion temperature, parking brake function.

Performance Data

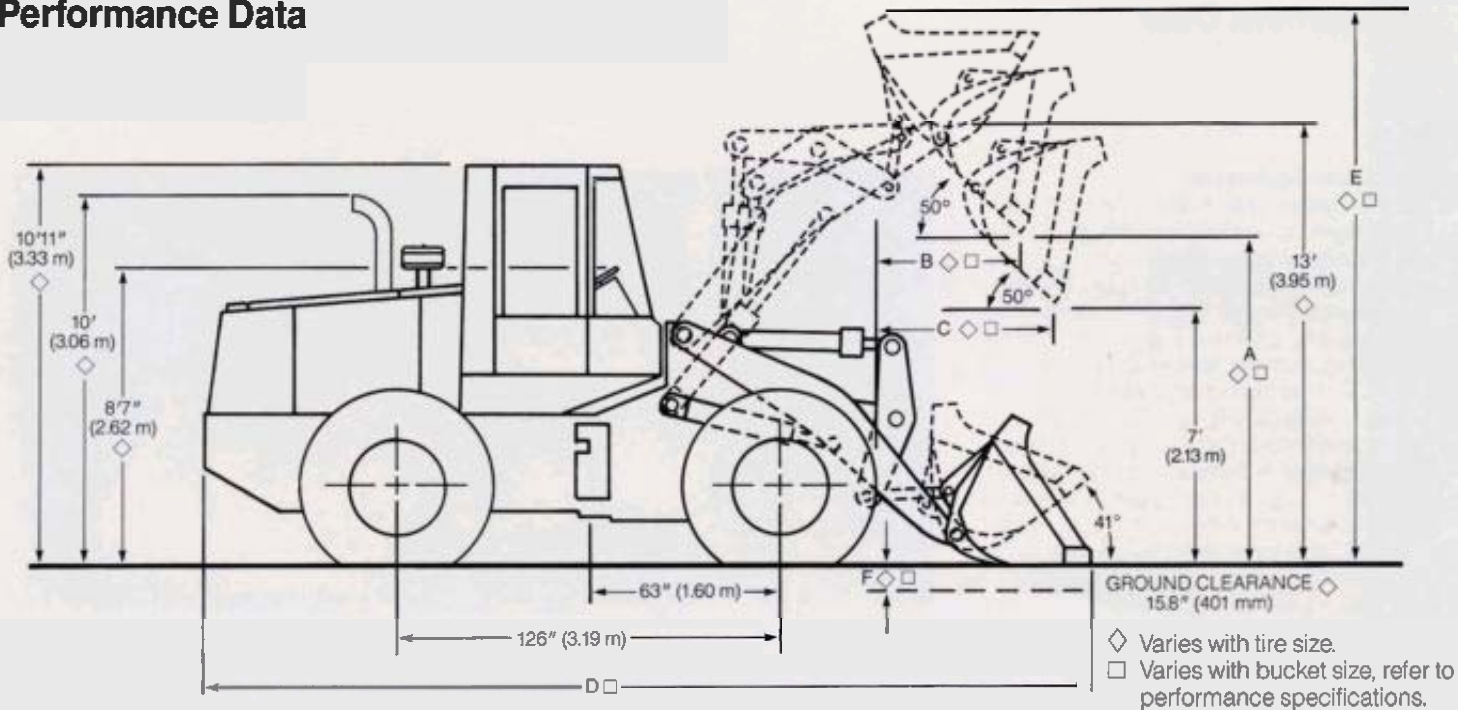

Performance Specifications — Loader specifications are per SAE J732c, J1234, J695, J742 and J818 except that the effects of weight and dimensions of teeth are included in the data where the bucket is so equipped.

Bucket type	Bucket configuration	General Purpose						Loose Material		4-IN-1®			
		Bucket only	Bucket w/ bolt-on edge	Bucket w/ teeth	Bucket only	Bucket w/ bolt-on edge	Bucket w/ teeth	Bucket w/ teeth segments	Bucket only	Bucket w/ bolt-on edge	Bucket w/ teeth		
SAE heaped capacity	yd ³ (m ³)	3.0 (2.29)	3.25 (2.48)	3.0 (2.29)	3.50 (2.68)	3.67 (2.81)	3.50 (2.68)	3.67 (2.81)	4.0 (3.06)	4.10 (3.13)	3.0 (2.29)	3.25 (2.48)	3.0 (2.29)
SAE struck capacity	yd ³ (m ³)	2.63 (2.01)	2.76 (2.11)	2.83 (2.01)	3.03 (2.32)	3.17 (2.42)	3.03 (2.32)	3.17 (2.42)	3.41 (2.81)	3.55 (2.71)	2.52 (1.93)	2.71 (2.07)	2.52 (1.93)
Bucket width	in (m)	109 (2.77)	109 (2.77)	111.5 (2.83)	109 (2.77)	109 (2.77)	111.5 (2.83)	111.5 (2.83)	109 (2.77)	109 (2.77)	109 (2.77)	109 (2.77)	111.5 (2.83)
Bucket weight	lb (kg)	2780 (1261)	3310 (1501)	3080 (1397)	2905 (1318)	3435 (1558)	3205 (1454)	3615 (1640)	2975 (1349)	3505 (1590)	4396 (1994)	4815 (2184)	4696 (2130)
A - Dump clearance @ 45° full height*	ft, in (m)	9'11" (3.02)	9'8" (2.95)	9'4" (2.86)	9'9" (2.97)	9'6" (2.90)	9'2" (2.79)	9'2" (2.79)	9'6" (2.90)	9'3" (2.82)	9'9" (2.97)	9'6" (2.90)	9'2" (2.79)
B - Bucket reach @ 45° dump, full height*	ft, in (m)	3'6" (1.06)	3'7" (1.09)	3'11" (1.19)	3'8" (1.12)	3'9" (1.15)	4'2" (1.26)	4'2" (1.26)	3'11" (1.19)	4'0" (1.23)	3'2" (.97)	3'3" (.99)	3'8" (1.12)
C - Bucket reach @ 45° dump, 7' (2.13 m) height*	ft, in (m)	5'5" (1.64)	5'4" (1.64)	5'7" (1.69)	5'6" (1.68)	5'6" (1.69)	5'8" (1.72)	5'8" (1.72)	5'8" (1.71)	5'7" (1.70)	5'0" (1.52)	5'0" (1.52)	5'2" (1.57)
D - Overall length	ft, in (m)	24'2" (7.37)	24'5" (7.44)	24'11" (7.59)	24'5" (7.44)	24'8" (7.52)	25'2" (7.67)	25'2" (7.67)	24'10" (7.57)	25'0" (7.62)	24'4" (7.42)	24'7" (7.48)	25'1" (7.63)
E - Overall height†	ft, in (m)	17'2" (5.23)	17'2" (5.23)	17'2" (5.23)	17'6" (5.33)	17'6" (5.33)	17'8" (5.33)	17'6" (5.33)	17'10" (5.44)	17'10" (5.44)	19'7" (5.96)	19'9" (6.02)	20'0" (6.10)
F - Digging depth	in (mm)	35" (89)	48" (122)	35" (89)	35" (89)	48" (122)	35" (89)	48" (122)	35" (89)	48" (122)	76" (193)	88" (224)	76" (193)
Loader clearance circle, bucket at carry	ft, in (m)	41'2" (12.54)	41'4" (12.60)	41'9" (12.71)	41'4" (12.59)	41'5" (12.62)	41'11" (12.76)	41'11" (12.76)	41'6" (12.65)	41'7" (12.68)	41'3" (12.58)	41'6" (12.64)	41'10" (12.76)
SAE breakout force	lbf (kN)	38,713 (172.2)	35,527 (158.0)	38,353 (170.6)	35,295 (157.0)	32,539 (144.7)	34,958 (155.5)	32,340 (143.9)	31,767 (141.3)	29,491 (131.2)	38,858 (172.8)	35,443 (157.7)	38,413 (170.9)
SAE tipping load straight*	lb (kg)	29,109 (13,204)	28,262 (12,819)	28,735 (13,034)	28,761 (13,046)	27,965 (12,685)	28,375 (12,871)	27,729 (12,578)	28,491 (12,933)	27,606 (12,522)	26,567 (11,997)	25,865 (11,732)	26,104 (11,841)
40° turn*	lb (kg)	23,981 (10,878)	23,168 (10,509)	23,610 (10,709)	23,646 (10,726)	22,875 (10,376)	23,273 (10,558)	22,841 (10,270)	23,393 (10,611)	22,551 (10,229)	21,804 (9,799)	20,927 (9,492)	21,192 (9,608)
Operating load*	lb (kg)	11,990 (5,443)	11,584 (5,254)	11,805 (5,355)	11,823 (5,363)	11,437 (5,188)	11,636 (5,278)	11,320 (5,135)	11,696 (5,305)	11,275 (5,114)	10,802 (4,900)	10,463 (4,746)	10,591 (4,804)
SAE operating weight*	lb (kg)	36,010 (16,334)	36,540 (16,574)	36,310 (16,470)	36,135 (16,391)	36,695 (16,631)	36,435 (16,527)	36,845 (16,713)	36,205 (16,422)	36,735 (16,663)	37,980 (17,243)	38,099 (17,281)	37,980 (17,227)

* For selected items, adjust operating dimensions, operating weight and tipping loads as shown in the following tables. Spec loader is a fully serviced unit that includes all standard equipment, 23.5 x 25, L2 12PR tires, ROPS cab, optional 2000-lb (908-kg) auxiliary counterweight, standard batteries, fenders, optional lighting package and 175-lb (79-kg) operator.

OPERATING DIMENSIONS

Tire options 20.5 x 25 23.5 x 25
Tread 82" (2.08 m) 82" (2.08 m)
Width over tires 103.8" (2.64 m) 106.4" (2.70 m)
Change in vertical dimensions -1.8" (45.7 mm) 0
Change in horizontal dimensions B and C +2.5" (63.5 mm) 0

Performance Data

Selected Options	Operating Weight Adjustments		Tipping Load Adjustments			
	lb	(kg)	Straight		40° Turn	
20.5 x 25, L2, 16PR	-1580	-717	-578	-262	-251	-114
▲ 20.5 x 25, L2, 16PR w/75% CaCl ₂	+360	+163	+2186	+991	+2099	+952
20.5 x 25, L3, 16PR	-1320	-559	-430	-195	-116	-53
▲ 20.5 x 25, L3, 16PR w/75% CaCl ₂	+620	+281	+2319	+1052	+2206	+1000
20.5 x R25 XHAT*	-1040	-472	-339	-154	-113	-51
▲ 20.5 x R25 XHAT* w/75% CaCl ₂	+1050	+478	+2596	+1178	+2351	+1066
20.5 x R25 XGLAT*	-1480	-672	-420	-190	-3	-2
▲ 20.5 x R25 XGLAT* w/75% CaCl ₂	+610	+276	+2188	+993	+1948	+883
23.5 x 25, L2, 12PR	0	0	0	0	0	0
23.5 x 25, L3, 12PR	+440	+199	+260	+118	+200	+91
23.5 x R25 XHAT*	+780	+353	+1018	+462	+1111	+504
With auxiliary 1000 lb (454 kg) counterweight ILO ballast	+1000	+454	+2023	+917	+1636	+742
ROPS canopy	-295	-134	-231	-105	-203	-92
Without fenders	-67	-30	-20	-9	-9	-4

▲ These tire adjustment values include rear tire ballast, but not the optional 1000-lb (454-kg) auxiliary counterweight. Use of rear tire ballast with the auxiliary 1000 lb (454 kg) counterweight or 23.5 x 25 tires is neither recommended nor approved. Rear tire ballast involves filling the tires 75% full with a solution of 5 pounds (2.27 kg) of calcium chloride per gallon (3.79 L) of water.

4-IN-1 BUCKET SPECIFICATIONS

Reach @ 45° dump angle, 7'0"
(2.13 m) clearance, 5' (1.52 m)

Tilt back @ ground level, 44°

◇ Varies with tire size - refer to performance specifications.

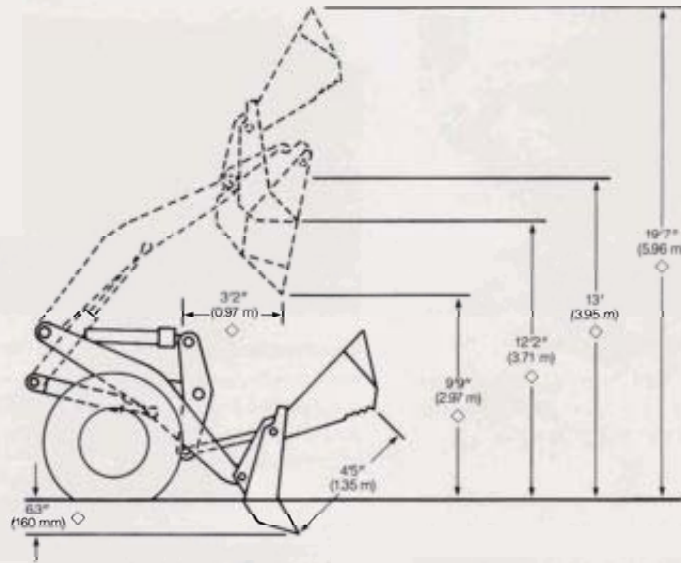

821 BUCKET SELECTION CHART

Spec loader is a fully serviced unit that includes all standard equipment, 23.5 x 25, L2 12PR tires (except as noted), ROPS cab, counterweight and ballast as noted, standard batteries, fenders, optional extra lighting package and 175-lb (79-kg) operator.

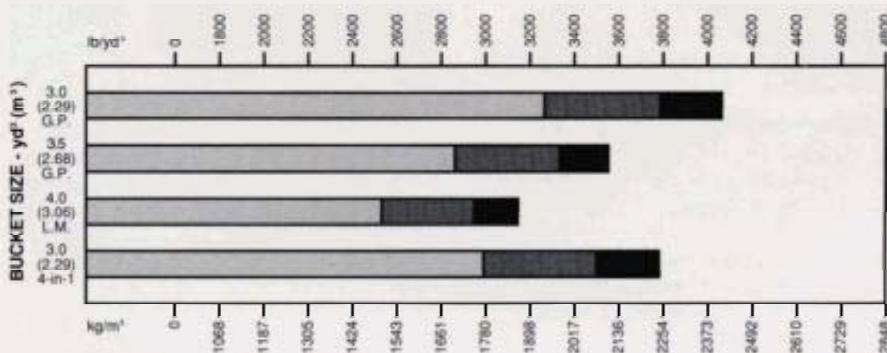

MATERIAL	lb/yd³	kg/m³
Sand, wet	3500	2075
Sand & Gravel, wet	3375	2000
Gravel, wet 1/2" x 2"	3375	2000
Sand, slightly damp	3240	1920
(graveled sand)	3240	1920
Clay & gravel, wet	3085	1830
Slag, broken	2970	1760
Trap rock, broken	2950	1750
Sand & gravel, dry	2916	1730
Earth, soft loose mud	2916	1730
Gravel, dry, 1/2" x 2"	2835	1680
Granite, broken or crushed	2778	1645
Stone, crushed	2700	1600
Sand, dry loose	2700	1600
Cyclium, crushed	2700	1600
Gravel, sand & clay, loose	2700	1600
Earth, wet excavated	2700	1600
Clay & gravel, dry	2700	1600
Clay, wet lumps	2700	1600
Limestone, broken or crushed	2625	1555
Gravel, loose dry	2565	1520
Sandstone, broken	2550	1510
Earth, moist excavated	2430	1440
Earth, loam, dry excavated	2300	1245
Coal, anthracite, broken	1875	1130
Clay, dry excavated	1845	1095
Clay, dry lumps	1822	1080
Coal, bituminous, broken	1413	840
Garbage, wet	1350	801
Ashes	1100	653
Sludge	865	513
Snow, wet	400	237
Snow, dry	150	89
	400	237

Bucket recommendations shown above are based on normal materials and average operating conditions. When selecting the proper bucket for a specific application other factors, such as loadability, material characteristics, terrain and other pertinent job conditions must also be considered.

821 Features



Z-Bar Linkage

A single, 7" (178 mm) diameter bucket cylinder operates through a massive, ductile iron bellcrank to deliver 38,713 lbf (172.2 kN) breakout force at the bucket.



Bolted Gland Cylinders

All loader cylinders are of bolted gland design for easy field serviceability. Sealed loader linkage pins and bushings increase lubrication intervals up to 100 hours.



Hydraulic-Assist Controls

Five control lever options are available for the 2, 3 or 4 spool sectional valves. Height control and return to travel are also available.



Electric Power Shifting

A single lever, twist grip simplifies gear selection. This same lever also provides forward and reverse power shuttle.



Electronic Monitoring

Instrumentation includes multi-level visual and audible warnings of all vital machine functions as well as non-vital service requirements and information notification.



Comfort Cab

The optional ROPS cab features large areas of tinted safety glass for excellent visibility. A tilting steering column is standard. Brake pedals are suspended for easy operation.



Articulation Joint

In the joint area, hose routings are clean and easily accessible. Cylinders are mounted for easy accessibility. Drive shaft "U" joints are lubricated for life.



Easy Serviceability

Sight glasses show brake, hydraulic and transmission oil fluid levels. The sight glass allows warm and cold oil checks.



Fast Access

The rear, swing-open grille provides access to batteries, radiator, and oil cooler. The back-up alarm and cold-start bottle are also located in this compartment.

Equipment Data

Optional Equipment

AM/FM stereo radio • Air conditioning • Anti-vandalism lock-up kit • Batteries, heavy-duty • Beacon, rotating • Between teeth edge protection segments • Bolt-on cutting edge • Brackets, lift and tie down • Bucket teeth • Buckets, general purpose, material handling, multi-purpose • Cold weather start aid • Compressed air dryer • Counterweight, rear, 2000 lb (908 kg) or 1000 lb (454 kg) • Differential, no-spin • FACT coupler system, male master • Fenders, front • Gauges: voltmeter, engine oil pressure, air pressure, transmission temperature • Height control and return to travel, automatic • Hydraulics, two spool w/two levers, two spool w/one lever, three spool w/three levers, three spool w/two levers, four spool w/two levers • Light, auxiliary (2 front driving, 2 front working, 2 front parking, turn signals/flashers front and rear) • Pin and clevis hitch • Pintle hitch • Precleaner • ROPS cab with following features: inside mirror, full view tinted glass, heater, pressurization, defogger, 3 speed blower, full ventilation windows, dome light, front wiper, full frame lockable door • Radiator sand screen • Seat, deluxe suspension type • Secondary steering • Special paint • Suction fan • Tires, radials and bias ply • Washer, front; wiper, rear • West coast mirrors • Windshield and wiper for canopy • 3" (76 mm) non-retractable seat belt.



Sold and serviced by:

Note: All specifications are stated in accordance with SAE Standards or Recommended Practices, where applicable.

Important

J I Case Company reserves the right to change these specifications without notice and without incurring any obligation relating to such change. Unit illustrated is equipped with non-standard items

J I Case

A Tenneco Company
700 State Street, Racine, WI 53404 U.S.A.

