



2015 PRECISION DISK 500/500T  
**AIR DRILLS**  
PRODUCTIVITY TIPS



# GENERAL INFORMATION



- **More Accurate Seed Placement**
- **Simple Depth Control**
- **Accurate Seeding Rates**

Case IH is proud to introduce the Precision Disk 500 and 500T drills, engineered with input from the very start by producers, for producers.

Farmers like you told us what you want and need, and we listened. You asked for a mounted seed tank option, accurate seed placement technology and better depth control for better stands and yields, and the ability to work in varying tillage and residue systems. Producers said these drills should be highly productive with minimal maintenance requirements. They should be offered in various sizes, but still be able to be transported with ease.

We listened to you and went to work. Our team of engineers built these drills from the ground up to give producers exactly what they asked for.

The Precision Disk 500 and 500T drills have an all-new frame that delivers increased durability and reduced setup time. They feature an all-new single disk opener and mounted tank for efficient, productive seeding. Growers will come to depend on the unmatched seed placement accuracy and the ability to reach higher ground speeds (5-8 mph), all with lower maintenance requirements. In addition, producers can obtain accurate seed and fertilizer placement in any tillage system, thanks to the patented, parallel-link row unit and unique design. We're proud to introduce the disk drill technology customers want and need.

***Welcome to your all-new Case IH Precision Disk Drill.***

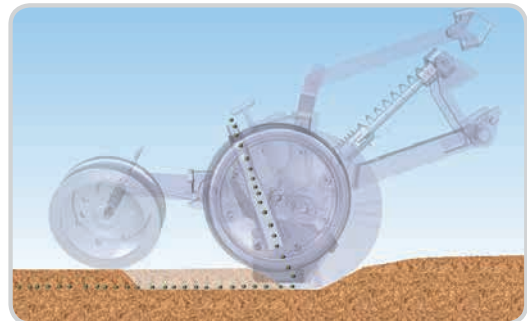

## CONTENTS

General Information .....	2
Disk Drill Configurations .....	3
Safety .....	4
Getting Ready .....	5
Service Inspection .....	6
Operation .....	7-9
Adjustments .....	10-15
Display Operation .....	16-29
Storage .....	30

# DISK DRILL CONFIGURATIONS



**CASE IH PRECISION DISK DRILLS ARE AVAILABLE IN MULTIPLE CONFIGURATIONS TO MATCH ANY FARMING OPERATION:**



- Precision Disk 500T – 25 ft. Single Fold, Mounted Tank
- Precision Disk 500T – 30 ft. Single Fold, Mounted Tank
- Precision Disk 500T – 40 ft. Single Fold, Mounted Tank



- Precision Disk 500 – 30 ft. Single Fold
- Precision Disk 500 – 40 ft. Single Fold



- Precision Disk 500 – 50 ft. Double Fold
- Precision Disk 500 – 60 ft. Double Fold

# SAFETY

At Case IH, we design and manufacture every piece of equipment with operator safety as a priority. As farm equipment has gotten larger, the size and weight of the equipment, coupled with the power of hydraulics and mechanical systems used to manipulate and control machines, makes a constant awareness of safety a foremost requirement of any operator. We also understand that seeding time places added anxiety and stress on operators who know that the success of a full year is at stake every time they go to the field. However, hurrying never relieves the operator of their responsibility to operate the machine safely. Take a few minutes to review the Operator's Manual safety information before starting each year. The payback for your time should be a safer and more successful planting season.

**Do not take shortcuts, thinking that an accident takes time to happen. Accidents can happen in seconds, too often leaving someone plenty time to think about how the accident could have avoided—while they heal.**

## GENERAL SAFETY RULES

- Always remember that the Operator's Manual is first and always the "go to" resource when you have questions about how to operate your machine. The following information is a generalized review of Safety rules. Refer to the Operator's Manual for complete information.
- One of the main features of large planting equipment is the ability to quickly move from one farm to another, using public roadways. Take time to become familiar with the traffic laws in your locality and how they apply to your large planting equipment.
- When operating on public roads always use lights, flashers and turn signals for maximum visibility. Maintain a clean and visible Slow-Moving Vehicle sign on the rear of the machine.
- Be a good neighbor and pull over to let traffic pass if possible to avoid creating unnecessary delay and stress for other drivers.
- For best field performance and the most secure road transport, make sure the weight of the implement does not exceed the recommended towing capacity of the tractor being used. This is especially important in areas with high traffic and hills that increase the braking and stopping demands necessary to maintain safe control.
- Do not exceed the drawbar or towing capacity of the tractor. When transporting front-fold planters, empty seed and fertilizer boxes and tanks whenever possible to reduce tractor drawbar load and total planter weight.
- When transporting equipment, maintain safe maximum travel speeds to assure complete control, and the ability to stop in case of emergency. Refer to tractor and planter Operator's Manual recommendations for maximum transport loading and weight.
- Removing guards for service work is no excuse to leave guards off during operation. Guards are intended to protect operators and any other persons, and must remain intact and installed as originally designed.
- Review the Operator's Manual to identify and understand the use of service locks prior to starting service operations.
- Engage service locks for all service operations. Use jackstands or secure blocking when working under or around raised equipment. Never work on the Drill without securely setting and locking service and transport locks in position and removing machine weight from the hydraulics systems.
- When servicing ground engaging components such as opening Disks and scrapers, use special care to avoid points and edges worn sharp during use.
- Always keep tires inflated to the specifications published in your Operator Manual. Service tires carefully, observing Operator's Manual instructions and rules.
- Chemical application is often an integral part of planting. Use the utmost care to protect yourself, other people, and the environment from the effects of overexposure to agricultural chemicals.
- Follow label instructions for proper chemical mixing, handling and container disposal methods.
- Be familiar with safety procedures for immediate first aid should you accidentally contact chemical substances.
- Use the proper protective clothing and safety equipment when handling chemicals. Don't take chances-work safe.
- Chemicals are supplied with Material Safety Data Sheets (MSDS) that provide full information about the chemical, its effects on exposure, and first aid needs in the event of an emergency. Keep your MSDS file up-to-date and available for first responders in case of emergency.
- Observe and inspect all warning decals on the machine, and replace any decals that are damaged and unreadable.
- Never allow the machine to be raised or lowered while service is being performed. Numerous linkages are used to move and suspend components. Pinch points between linkage and other parts of the machine are inherent, and could cause injury to an unsuspecting worker if machine movement is initiated

# GETTING READY

Your machine has a Product Identification Number (PIN) plate. For easy reference, locate the PIN plate and record the number. When requiring repair parts, take this number into your dealer.

Model: \_\_\_\_\_

PIN Number: \_\_\_\_\_

## PRE-SEEDING INSPECTION CHECKLIST

### CHECKLIST FOR YOUR “WALK AROUND” INSPECTION

Refer to the maintenance section of your operator’s manual for your maintenance schedule, suggested lubricants, etc.

	OK	Replace/ Adjust		OK	Replace/ Adjust	
<b>SEED DELIVERY</b>						
<b>SEED DELIVERY LINES</b>						
Primary Hose Condition – Obstructions/Tightness	<input type="checkbox"/>	<input type="checkbox"/>	<b>GAUGE WHEELS</b> Rubber/Rim Condition Bearing Condition – smooth rotation, etc. Seed flap inspection	<input type="checkbox"/>	<input type="checkbox"/>	
Secondary Hose Condition – Obstructions/Tightness	<input type="checkbox"/>	<input type="checkbox"/>		<input type="checkbox"/>	<input type="checkbox"/>	
Y-Splitter Condition/Obstructions	<input type="checkbox"/>	<input type="checkbox"/>		<input type="checkbox"/>	<input type="checkbox"/>	
<b>SEED METER DRIVE</b>						
Install Chains	<input type="checkbox"/>	<input type="checkbox"/>	<b>FIRMING/CLOSING WHEEL</b> Bearing Condition – smooth rotation, etc. Splits, Cracks	<input type="checkbox"/>	<input type="checkbox"/>	
Lubrication	<input type="checkbox"/>	<input type="checkbox"/>		<input type="checkbox"/>	<input type="checkbox"/>	
<b>ROW UNIT</b>						
<b>ROW UNIT PARALLEL LINKAGE</b>						
Linkage – wear	<input type="checkbox"/>	<input type="checkbox"/>	<b>GENERAL</b> <b>TIRES AND WHEELS</b> Inflation Pressure Wear/Damage Bolt Tightness Walking Tandem - Grease Caster	<input type="checkbox"/>	<input type="checkbox"/>	
<b>DEPTH CONTROL</b>						
Down Pressure Spring	<input type="checkbox"/>	<input type="checkbox"/>		<input type="checkbox"/>	<input type="checkbox"/>	
Grease depth setting handle pivot point	<input type="checkbox"/>	<input type="checkbox"/>		<input type="checkbox"/>	<input type="checkbox"/>	
Set depth	<input type="checkbox"/>	<input type="checkbox"/>	<b>HYDRAULIC DRIVE</b> Hyd. Motor Oil Leaks Shaft Alignment/U-joints Drive Chain Tension/Lubrication Calibrate	<input type="checkbox"/>	<input type="checkbox"/>	
<b>OPENER DISKS</b>						
Opener disk wear – Worn out at 16 in. (406 mm)	<input type="checkbox"/>	<input type="checkbox"/>		<input type="checkbox"/>	<input type="checkbox"/>	
Bear/hub condition – smooth rotation, etc.	<input type="checkbox"/>	<input type="checkbox"/>	<b>ELECTRICAL</b> Wire Harnesses/Tie Straps Seed Sensors, clean Hopper Seed Level Sensor Monitor (operation, functionality) Row Clutch Function	<input type="checkbox"/>	<input type="checkbox"/>	
<b>SCRAPER &amp; TRASH SHIELD</b>						
Scraper Wear – Adjust the scraper up at opener disk diameter 17 in. (432 mm)	<input type="checkbox"/>	<input type="checkbox"/>		<input type="checkbox"/>	<input type="checkbox"/>	
Trash Shield Wear/position	<input type="checkbox"/>	<input type="checkbox"/>		<input type="checkbox"/>	<input type="checkbox"/>	

# SERVICE INSPECTIONS

## REMOVING THE DRILL FROM STORAGE

1. Clean hydraulic hose couplers before connecting to the tractor.
2. Make sure tires are properly inflated before moving the disk drill.
3. Remove protective grease and clean exposed cylinder rods.
4. Carefully raise the Disk Drill, making sure settling during storage, or other closely-parked equipment does not result in interference when raising and moving the drill.
5. Inspect the entire disk drill for signs of rodent or other damage. Check hydraulic hoses and wiring harnesses for proper routing, and tie strap as needed.
6. Re-install drive chains.
7. Lubricate all grease fittings. Do not over-grease fittings lubricated when the unit was put in storage.
8. Check seed hoses and sensors for blockages.
9. Check for debris and clean the seed tank with pressurized air if needed.
10. Read the Operator's Manual for both the drill and display operation.



## HYDRAULIC CONTROL REQUIREMENTS

Operation of the hydraulic driven fan on the mounted tank requires the tractor to have either a load sensing hydraulic system or a closed center system with flow control. These types of hydraulic systems usually have large oil reservoirs and increased oil cooling capacity.

The required tractor capacities are listed in the Tractor Hydraulic Requirements Chart below.



PRECISION DISK 500/500T - TRACTOR HYDRAULIC REQUIREMENTS		
Description	Minimum GPM Flow from Tractor	Number of Tractor Remotes
Precision Disk 500T – all sizes	30 GPM (113 lpm) @ 2500 PSI (17.2 MPa)	3 (1-Lift/Lower, 2-Wing Fold, 3- Fan/Meter Drive)
Precision Disk 500 – 30 ft & 40 ft	15 GPM (57 lpm) @ 2500 PSI (17.2 MPa)	2 (plus Air Cart) (1-Lift/Lower, 2-Wing Fold)
Precision Disk 500 – 50 ft & 60 ft	30 GPM (113 lpm) @ 2500 PSI (17.2 MPa)	2 (plus Air Cart) (1-Lift/Lower, 2-Wing Fold)



# OPERATION

## TRACTOR/DRILL HOOKUP

Some specific details that apply to general tractor/drill hook-up include:

- Tractor horsepower and weight must be adequate to maintain control of the planter in the field and transport situations. Under no circumstances should the weight of the towed equipment be more than 1.5 times the weight of the towing vehicle. This is especially important when operating on hilly or unstable soil, when additional control is required.
- The Precision Disk drill is equipped with several hydraulic motors that require low back pressure case drain returns to the tractor. Low pressure is defined as 25 PSI or less under full-flow conditions. Refer to your tractor Operator's Manual for correct low-pressure return connections for your tractor.
- A warning tag on the case drain hose reminds the operator that incorrect connection of the case drain may damage the vacuum fan motor. Motor failures due to improper case drain connection are not covered by warranty.
- Electrical system requirements include the standard seven-pin connector socket for safety lighting. In addition, tractor monitor or AFS system wiring may be required, according to installed options.
- Secure the drill (1) to the tractor drawbar using an adequate draw pin (3) that is locked in place with a linch pin or other proper locking device.
- Connect the safety chain (4) between the tractor and the drill as shown.
- When hitching to a tractor, route the chain through the loop near the hammer strap (if equipped) and around the drawbar intermediate support (2) as shown.

**NOTICE:** Be sure the safety chain is long enough. If using a Precision Air Cart, please check the Air Cart Operators manual for proper chain positioning.

When hookup is complete, thoroughly inspect the routing of all hoses and electrical harnesses between the tractor and drill.

- Steer the tractor/drill combination through complete right and left turns while observing the hitch area to assure no interference develops during operation and maneuvering.

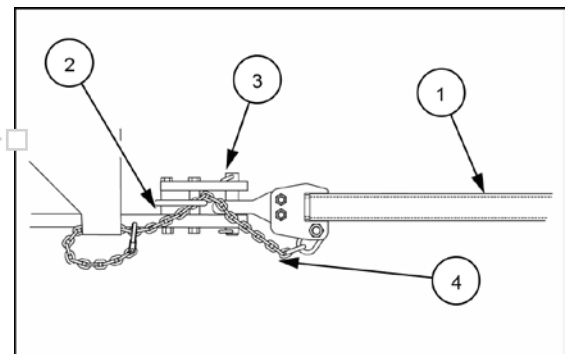
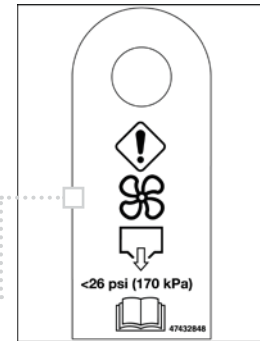



## GENERAL SEEDING TIPS

Several important factors must be considered when seeding. General factors are:

- Dig often to check seed depth accuracy and proper closing.
- After lowering the disk drill ranks, place the frame control remote valve in the engaged position to provide down pressure to the ranks of row units.

Check tractor hydraulic flow adjustments for each drill function run direct from the tractor (Air Fan/ SeedDrive & Lift/Lower) after reaching operating temperature. **Do not** set the flow levels to 100% and leave. Flow levels should be set just above the required amount to reduce the potential for overheating and power consumption.



## SEEDING WITH A HYDRAULIC DRIVE DRILL

Hydraulic drive seeding equipment require different operating techniques than ground drive. Follow these tips to have a successful seeding season.

- Utilize **"Prime Control"** if starting to seed with the drill in the ground and starting from 0 mph. This will limit the gaps left due to Product Delay.



A seeding gap could be seen, if prime control is not used.



- Maintain constant and high enough engine RPM levels to keep high quality seeding operation. This engine RPM is typically between 1800-1900 engine RPMs. See the tractor operator's manual.
- Avoid sudden changes in ground speed to keep consistent placement.

Please reference the "Working Operations" section of the Drill Operator's Manual for more details.



# ADJUSTMENTS

## SELECT SUITABLE METER ROLLERS ( 500T ONLY)

	Extra Fine	Fine	Coarse
			
Alfalfa	<b>Recommended</b>	Not recommended	Not recommended
Canola	<b>Recommended</b>	Not recommended	Not recommended
Barley	Not recommended	Not recommended	<b>Recommended</b>
Flax	Not recommended	<b>Recommended</b>	Not recommended
Oats	Not recommended	Not recommended	<b>Recommended</b>
Rice	Not recommended	Not recommended	<b>Recommended</b>
Sorghum (Milo)	<b>Recommended – 5-40 lb/ac (5.6 -44.8 kg/ha)</b>	<b>Recommended – 25-120 lbs/ac (28-134.4kg/ha)</b>	Not recommended
Soybeans	Not recommended	Not recommended	<b>Recommended</b>
Wheat	Not recommended	Not recommended	<b>Recommended</b>

## SEED METER CHANGING

Changing the meter roller assembly for different crop types is easily done by removing the current door/meter assembly and installing the new roller/door assembly. The assemblies are removed by simply unscrewing one bolt on each side of the meter, unhooking the agitator linkage and then removing the entire assembly.

**Note:** Seed must be drained from the tank prior to removing the meter assembly.



# ADJUSTMENTS

## HYDRAULIC DRIVE AND GEAR RATIO ADJUSTMENT (500T ONLY)

The seed meter rollers are driven by a smooth running hydraulic drive (1). The single hydraulic motor provides the needed power and torque to seamlessly turn the seed drives at the required speed for precise rate control. The built-in speed sensor provides the needed feedback to accurately control motor speed.

The sprocket combination (2) can be changed to achieve the proper meter speed range for a seed type. There are two different ratios 1:1 and 3:1. **Note:** MY15 and after drills feature a 1.3:1 sprocket ratio instead of a 1:1 ratio. Loosen the chain tensioner and move the chain to the opposite sprocket combination, if needed.

Meter speed should be kept between 15 and 110 rpms for proper operation.

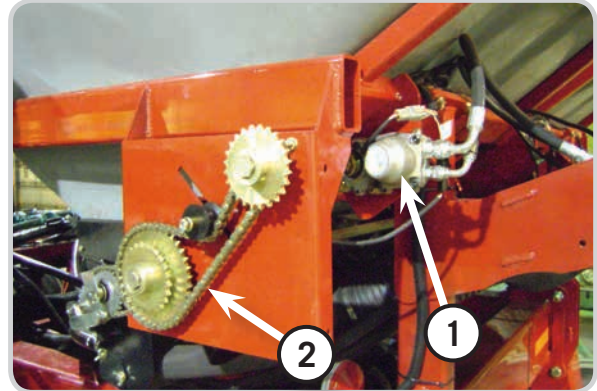

### TIP!

The AFS Pro 700 or ISOBUS compliant display provides a warning if the meter speed is too slow or too fast for the ground speed and product application rate. In that instance the drive sprocket ratio will likely need to be changed.

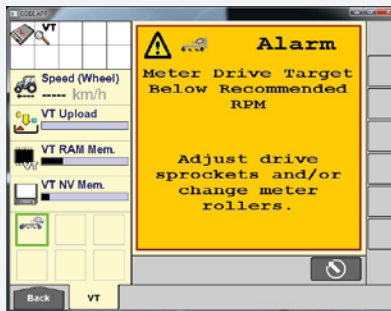

### SUGGESTED RATIOS PER CROP TYPE

SUGGESTED RATIOS PER CROP TYPE	
Alfalfa	3:1
Canola	3:1
Barley	3:1
Flax	3:1
Oats	3:1
Rice	3:1
Sorghum (Milo)	3:1
Soybeans	3:1 or 1:1 / 1.3:1
Wheat	1:1 / 1.3:1

## ADJUSTING SEED GATE POSITION (500T ONLY)

The seed gates regulate the amount of seed pouring from the tank into the meter roller segments. The gates need to be opened prior to seeding. Each gate has detents which allows the operator consistent adjustment between four positions – Closed, 1/3 open, 2/3 open and fully open.



Suggested positions for each crop type:

GATE POSITION	
Alfalfa	1/3 open
Canola	2/3 open
Barley	Full open
Flax	2/3 open
Oats	Full open
Rice	Full open
Sorghum (Milo)	2/3 open
Soybeans	Full open
Wheat	Full open

# ADJUSTMENTS

## FAN PRESSURE ADJUSTMENT (500T ONLY)

The AFS Pro 700 or ISOBUS compliant display provides feedback on the air pressure provided. The operator simply adjusts the hydraulic oil flow rate from the tractor remote valve to adjust to the desired air pressure rate shown on the display. Proper air pressure level is determined by an open line test.

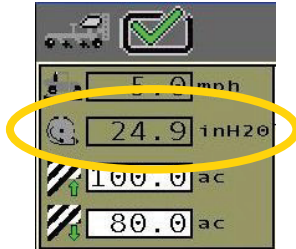

## DETERMINING ADEQUATE CARRYING VELOCITY

This calibration is critical to ensure optimal air velocity to carry seed from the mounted tank seed meter out to the row units.

- Too much air may cause the seed to have inaccurate placement in the seed furrow
- Too little air may cause seed to not consistently carry to all rows which will result in inconsistent seeding and can cause blockages

**NOTE:** To check if the fan speed and meter gate settings are suitable for seeding, check product placement behind several openers and observe the seed planting depth.

Use the following open hose method to determine adequate carrying velocity:

1. Remove one secondary hose (1) from an outside opener.
2. Fasten the hose (1) to the frame of the seeding tool.
  - The hose should be no more than **30 cm (12 in.)** below the bottom of the frame member, as shown (2).
  - Ensure the end of the hose (1) is flush with the top of the frame member, the outlets face straight up and the hose is not kinked.
3. Open the seed gates to all runs
4. Begin seeding at normal operating speed.
5. From a safe distance, observe the product coming out of the hose end.
  - The product (3) should discharge about **31-61 cm (12-24 in.)** above the hose (4)
  - STOP the meters if the product is not **31-61 cm (12-24 in.)** out of the tube.
  - Adjust the fan pressure to reach a product discharge of **31-61 cm (12-24 in.)**.

**Note:** In some crop types, the heights of 12-24 in. may not be achieved (large soybeans or example).

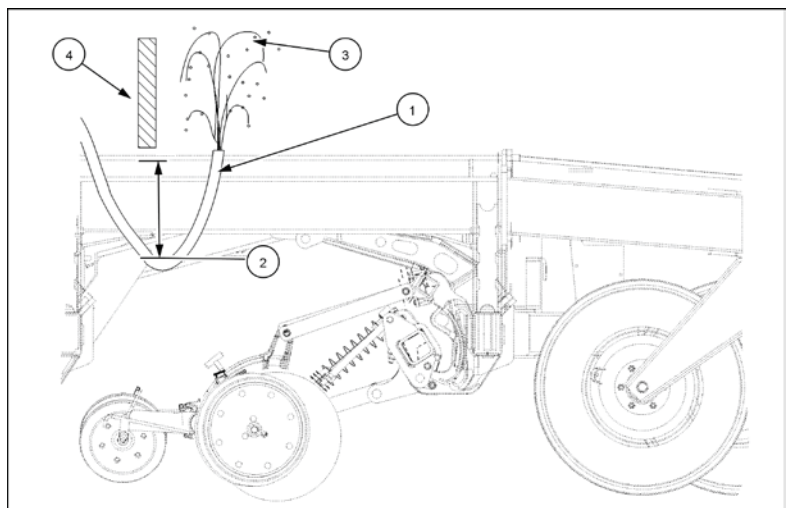

# ADJUSTMENTS

## ADJUST SEEDING DEPTH (1)

0-3.5 in. depths available (0 cm – 8.9 cm)

The openers that are in the wheel or tractor tire tracks may need to be set to a different depth. Check the seeding depth and adjust opener depth as required.

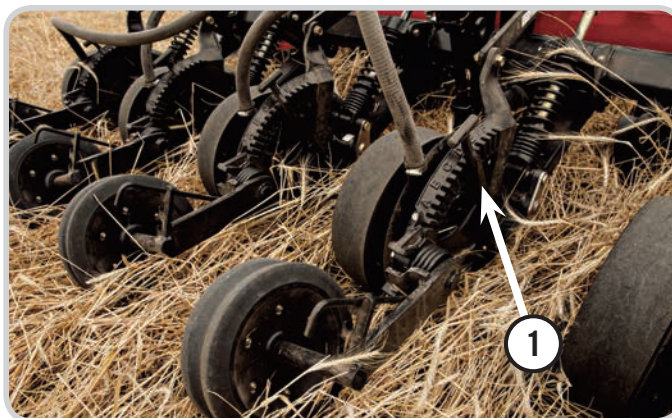

## ADJUST THE CLOSING WHEEL PRESSURE

At 1.5 in. of depth the pressure will be

- Position 1 - 59 lbs.
- Position 2 - 71 lbs.
- Position 3 - 84 lbs.

**Note:** Evaluate the closing quality. Depending on the seeding depth (typically around 1.25 in. (3.18 cm)), the closing wheel may have to be shifted to improve closing. A kit is available from your Case IH dealer (P/N – 47579960) to move the closing wheel either ½ in. (1.27 cm) or 1 in. (2.54 cm). This kit contains parts for eight row units.

- Position 3 - 84 lbs.
- Position 2 - 71 lbs.
- Position 1 - 59 lbs.

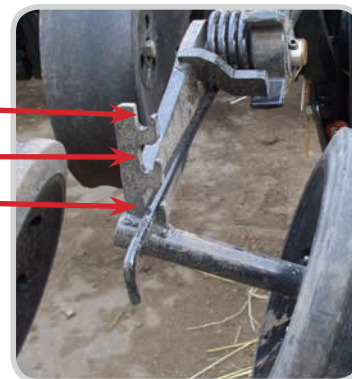

## ADJUST DOWN PRESSURE

The hydraulic down pressure system across the full width of the Precision Disk 500 & 500T can be adjusted, depending on how the Disk Drill is optioned. Manual (1) or In-cab down pressure adjustment (2) is available. The down pressure can be infinitely adjusted via a keypad or three, easy to use preset down pressure settings (press and hold the button to set).

The tractor hydraulic circuit must have continuous flow in order that the opener down pressure circuit is pressurized.

Available down pressure range is between 200-1300 psi (25 ft. & 30 ft.) or 200-1450 psi (40 ft., 50 ft., & 60 ft.) to provide ample down pressure in any soil condition.

Potential Ranges:

- Min till/conventional till - 200-600psi.
- No-till - 600psi +.

**NOTE:** Set the down pressure to achieve adequate opener penetration and depth control.

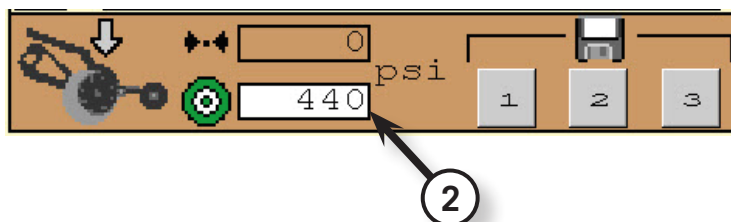
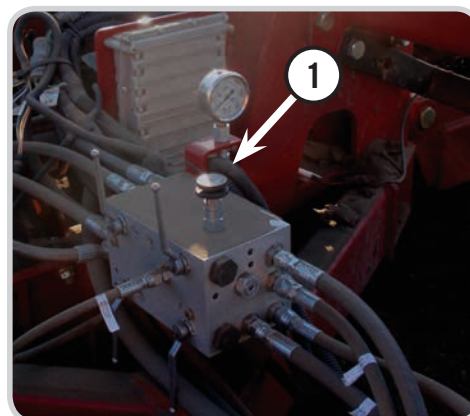

# ADJUSTMENTS

## OPENER DISK INSPECTION

The opener disks when new are **18 in. (45.7 cm)** in diameter.

The opener disk should be replaced when disks are worn to **16 in. (40.6 cm)**. A symptom of a worn disk is excessive hair pinning.

## SCRAPER ADJUSTMENT

Adjustment to the scraper and trash shield may be needed for development of a high quality seed trench as the opener disk wears.

The scraper and trash shield can be adjusted up and down by removing the retaining bolts and moving the scraper higher as the opener disk wears (typically at 17 in. (43 cm) the scraper will need to be adjusted to the next notch higher).

There should be no larger than a 0.051 in. (1.3 mm) gap between the blade and scraper at any point along the front edge of the scraper.

If hair pinning at the top or bottom of the the scraper is experienced, the scraper may need to be adjusted with washers.

### BUILD-UP AT TOP OF SCRAPER

If build-up is occurring where the scraper and trash shield meet, add a washer **P/N 86632589** to the front bolt **(1)** between the scraper bolt, the scraper and the scraper mount. Torque the bolts to **115 N·m (85 lb. ft.)**.

### BUILD-UP AT BOTTOM OF SCRAPER

If build-up is occurring where the scraper and trash shield meet, add a washer **P/N 86632589** to the back bolt **(2)** between the scraper bolt, the scraper and the scraper mount. Torque the bolts to **115 N·m (85 lb. ft.)**.

## SEED FLAP INSPECTION

A seed flap deflector is located behind the scraper and seed tube to help contain any seed that might attempt to bounce out of the seed trench.

Check the seed flap **(1)** for wear or breakage.

If openers are plugging, the seed flap can be removed when seeding in wet conditions.

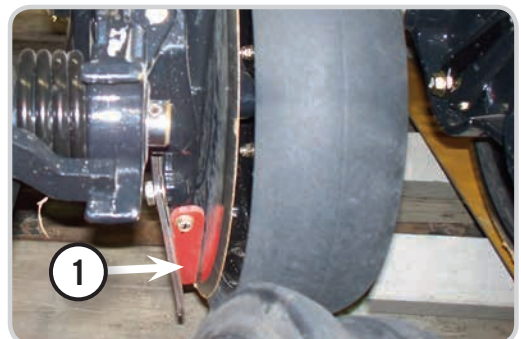
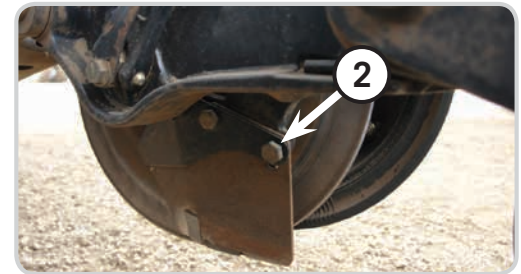

# ADJUSTMENTS

## SINGLE RANK OPERATION

The drill spacing on **19.1 cm (7.5 in.)** drills can be changed to **38.2 cm (15 in.)**; **30.5 cm (10 in.)** drills can be changed to **61 cm (20 in.)**, by locking out one rank of openers and setting the flow dividers to only put seed to the either the front or back rank.

### TIP!

Either rank can be used to seed with in this situation. It may be desirable to switch from back to front or front to back each year to keep opener disk wear even.

### TIP!

Wet and/or soft conditions may require both ranks to be placed in the ground to help float through the conditions.

1. Lift both ranks up to the their fully lifted position.
2. Adjust the correct combination of levers on the hydraulic block to lock either the front or rear rank up.

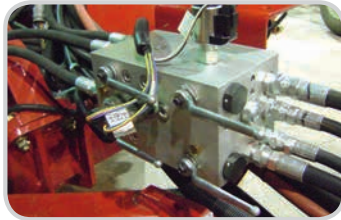

All ranks in use and seeding

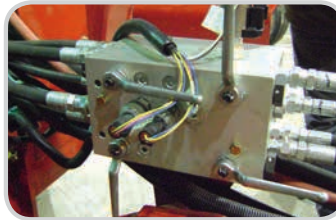

Front rank in use and seeding

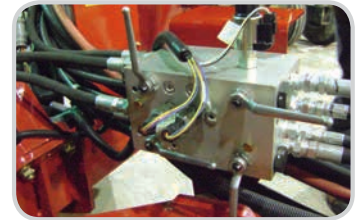

Rear rank in use and seeding

3. Insert the mechanical lock-up pins in the rank that is not seeding.
  4. Use the flow divider on each y-splitter (500T only) to direct the product flow as required. The arrow (1) on the splitter shows the product flow. Full seeding is shown.
- For the Precision Disk 500 w/ Air Cart, header inserts are available to split rank apply. See your dealer for details.

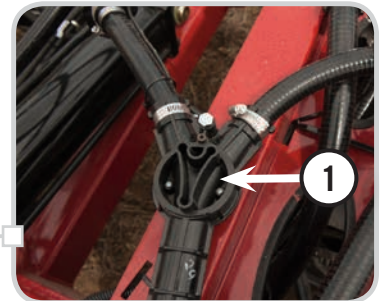
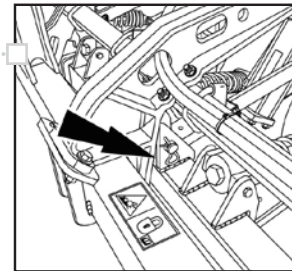

5. Adjust the Flow Set-up to detect the proper rows.

'BACK' > 'SETUP' > 'FLOW'



- Front Rank in use = Odd Rows
- Rear Rank in use = Even Rows

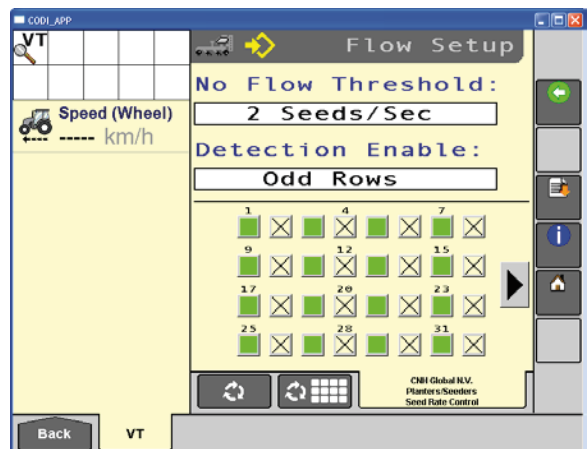

# DISPLAY OPERATION – 500T ONLY

## PERFORM PRODUCT CALIBRATION

Product metering calibrations are critical to accurately apply the correct seeding rates and are recommended for the following occasions:

- New precision disk drill
- Start of season
- Crop Type change
- Weight of crop change
- Seed meter roll change
- Gear set change (From 1:1 / 1.3:1 ratio to 3:1 ratio or visa versa)
- Major component change

To calibrate, you will need.

- Container, bag or pails to capture product at 2-3 locations across the unit.
- Weigh scale (A scale is available from your Case IH Dealer – P/N 47486597)
- Flat Screwdriver or 5/16-inch nut driver to remove/tighten the hose clamp
- Seed in the tank

The calibration number provides input to the drill controller regarding how much seed is being distributed based on seed meter configuration and crop.

- Calibration number is “lbs (kg) /100 rev(olutions)” of the seed drive motor output shaft (not the meter)
- Factory calibration value is set to “0lbs / 100 rev”

If a reliable cal number has been found in previous calibrations, the valid calibration number can be enter manually, if desired.

Use the calibration Wizard for instructions to perform the calibration.

To access the Meter Calibration Choose ‘Back’ (if needed) > ‘CAL’ > ‘Wizard’ Buttons. Follow the on-screen instructions.

### 1. Choose ‘BACK’ (to main screen) > ‘SETUP’ > ‘CAL’ > ‘Wizard’

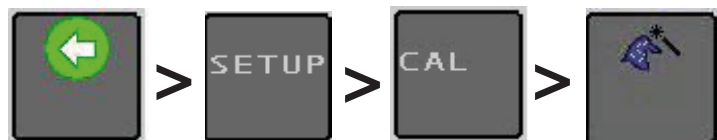

### 2. System Check

Check that implement is not moving and hydraulics to the fan/meter are engaged.

**TIP!** Only open the door above the meter sections that seed will be caught from. All others can remain closed, to prevent unwanted seed loss.

### 3. Prime

Prime the meter to be sure seed is in the meter. Seed should be delivered to the end of the delivery hose.

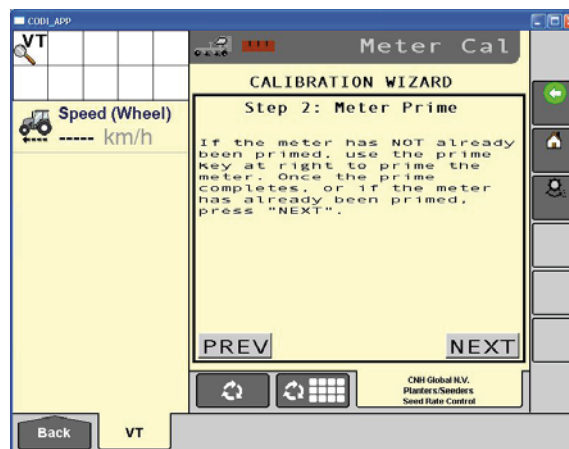
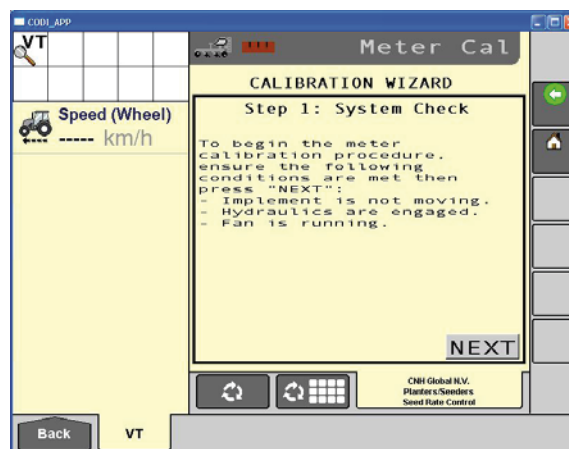
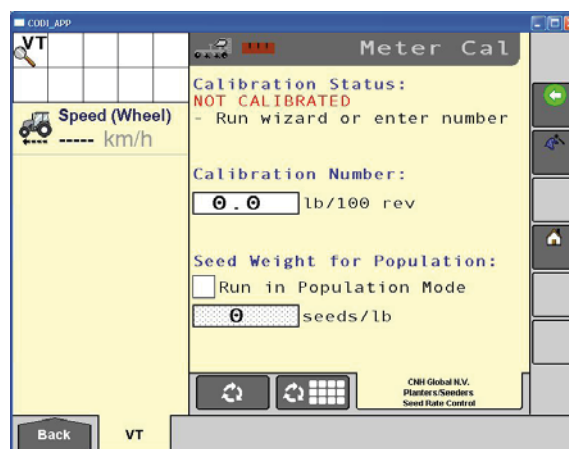



# DISPLAY OPERATION – 500T ONLY

## PERFORM PRODUCT CALIBRATION (continued)

### 4. Enter the Meter Cal Number.

The range of RPM can be between 15-115 RPM.

**Note!** This number is the drive motor speed. The meter has no speed sensor. All rate control is based off of the drive motor speed. If a calibration has never been performed before with this crop type, enter in 50 RPMs to start with.

**Note!** Once the typical RPM is found for a crop type/size, the calibration should be performed again using a meter RPM closer to the typical RPM

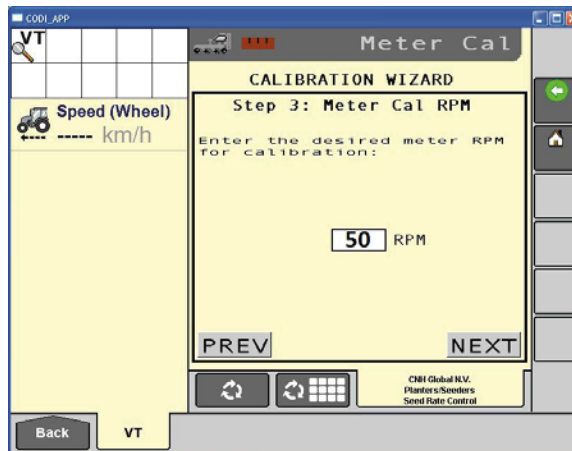

### 5. Set-up for Collection

Weigh each of the collection bag/container and record the weight(s).

Disconnect the either the Primary hose from the Y-Splitter or both secondary hoses from the row unit and adjust the Y-Splitter so that all the product from one meter section/primary run is directed in to the collection bag or bucket (1). All of the product from both hoses must be collected for an accurate calibration!

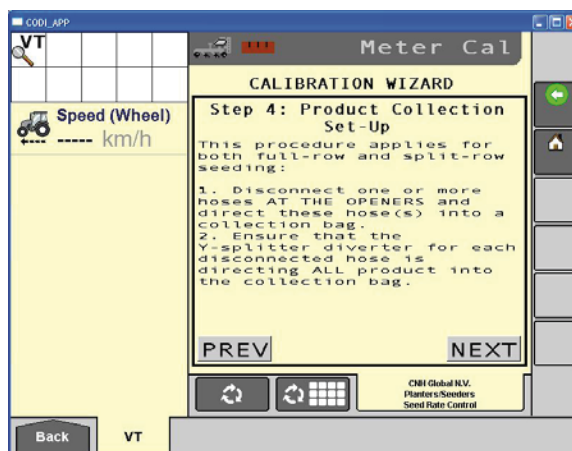

**TIP!** Tie the bag shut or cover the container so no seed is able to escape during the calibration. If no stationary calibration switch is installed, attached the bag securely to the frame of the drill.

**TIP!** Collect product from several locations across the drill (ex. One collection point per meter section)

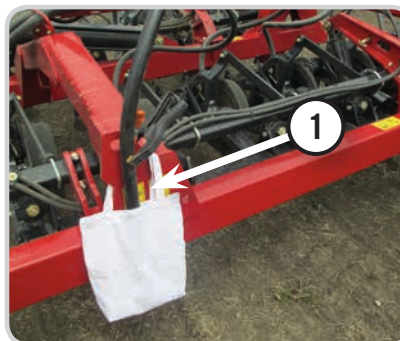

**TIP!** An easy to follow video of the the calibration process is available on web. Please scan the QR bar code to be linked directly to the video.



# DISPLAY OPERATION – 500T ONLY

## 6. Run the Calibration and Collect Product

### Drills without a Calibration Switch

If no calibration switch is installed on the drill begin driving above 2.5 mph (4-5 km/h). When ground speed above 2.5 mph is reached the meter will begin to turn at the RPM programmed in step 3.

**Note:** It is recommended to drive 3 mph or over during this calibration.

### Drills with a Calibration Switch

If a calibration switch (1) is installed on the drill, press and hold the switch. The meters will begin to turn and product will be metered.

**Note:** In both calibration methods, the 'targets counted' window will begin counting when the meter begins to turn. This number indicates that the system knows the meter is turning. The number shown does not have an affect on the final calibration number.

**In either configuration, collect a measureable amount of seed in the collection bag (2-3 lbs. minimum).**

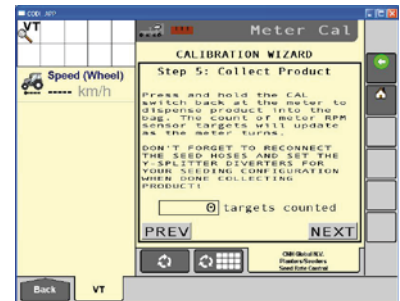
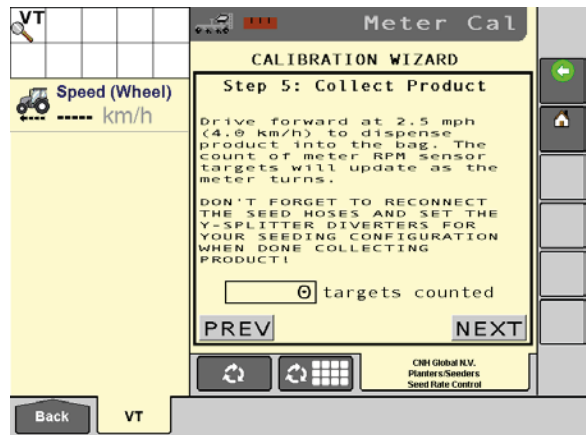
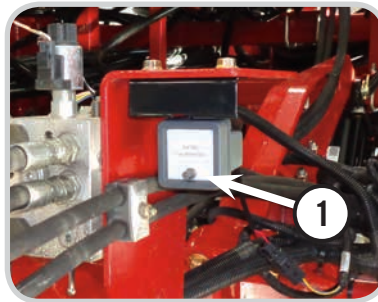

## 7. Weigh the product collected

Weigh each of the collection bag/containers and subtract the empty weight of the bag/container.

**TIP!** The weight of each bag should be nearly the same. If the weights of the containers vary significantly, empty the containers and perform the calibration again.

Add all of the product weights together and enter the total weight.

**Note:** The weight should be calculated in tenths of a pound (or kg). Do not enter ounces!

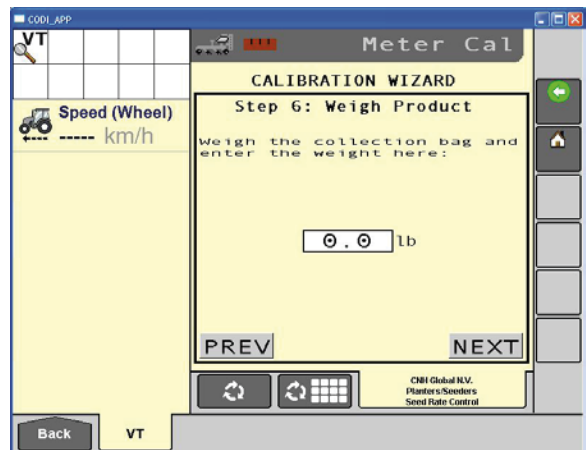

## 8. Enter the Number of Y-Splitters or Primary Runs product was collected from.

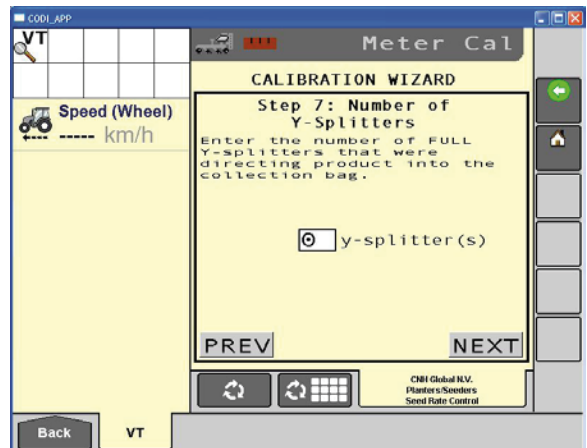



# DISPLAY OPERATION – 500T

## RUN IN POPULATION MODE

The disk drill normally operates in lbs (kg)/acre, however, some crop applications (ex. soybeans) can use “population mode” to allow the operator to enter in the desired seed per acre (or hectare) population (as opposed to lbs. (kg) per acre).

**Note!** The exact weight of the seed **must be** known and entered in for accurate population control in population mode.

1. Choose 'BACK' (to main screen) > 'SETUP' > 'CAL'



2. Check the box next to 'Run in Population Mode.'
3. Enter the seeds/lb (kg) value from the seed company identification tag.

**IMPORTANT!** This value must be checked anytime seed is added to be sure the value matches the seed suppliers value.

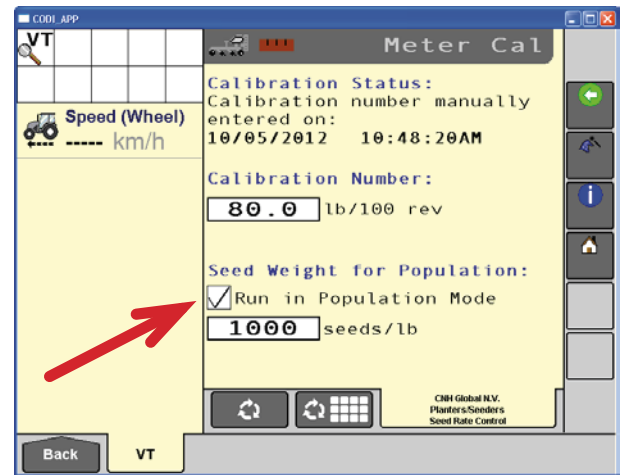

# DISPLAY OPERATION – 500T

## GROUND SPEED

Ground Speed is critical to achieving proper seeding rates.

There are three potential sources of ground speed listed.

If “---.” is displayed next to the Speed Source listing, that source is not currently available. If 0.0 or greater is shown, that source is available. Press the Grey box next to the option to make that selection the active ground speed source.

**Tractor ISO Speed** – Speed reported from an ISOBUS complete tractor TECU.

- If the wheel speed is less than 1.0 MPH, the disk drill shall use wheel speed.
- Otherwise, the disk drill shall use radar speed.
- If one or the other is lost, the drill will switch to the opposite.
- No GPS speed is available in this selection.

**VT ISO Speed** – This is the Virtual Terminal (VT) speed output selected in the VT setup screen for supported VTs. Using the AFS Pro 700 display this screen is found in Toolbox>VT (1)

‘Send ISO Speed’ places a speed signal on the Implement Bus for the implement Rate ECU to use for rate control and monitoring. If the source (Radar or GPS) is available, it will appear.

**Disk Drill GPS** – This is the speed from an optional GPS Speed Sensor installed on the rear railing of the Drill.

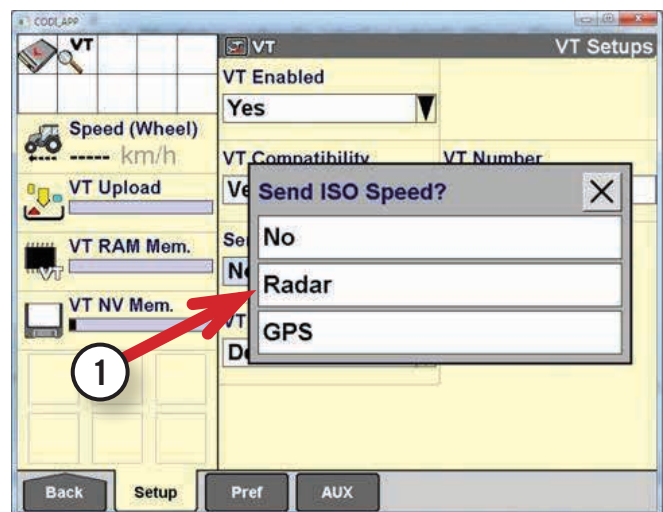
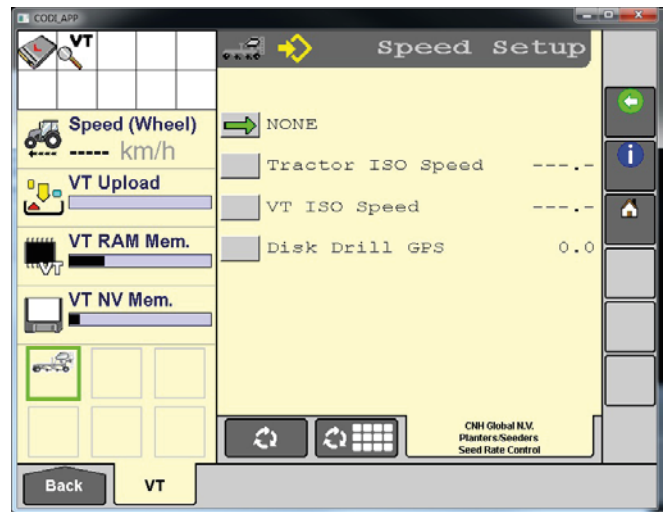

# DISPLAY OPERATION – 500T

## VT Icon



The Precision Disk Drill and Precision Air Cart use the Virtual Terminal to operate and monitor their seeding systems. Below is the screen layout of the Precision Disk 500T and the operations available on the main Run Screen in the Virtual Terminal

**Actual Rate**

**Section On/Off/Auto (Black – on; Grey Off)**

**Adjustable Target Rate (press for incremental adjustment buttons)**

**Implement Switch Position**

**Unit (Press for meter drive motor RPM)**

**3 preset rates (press & hold to program)**

**Change View – Bar Graph (shown) or blockage monitoring**

**Current row**

**Current Down Pressure**

**Three Pre-set Down Pressure Settings (press & hold to program)**

**Prime Button**

**Change View – Bar Graph (shown) or blockage monitoring**

**Target Down Pressure (infinitely adjustable)**

**Estimated population/rate for row**

Speed (Wheel) km/h  
 VT Upload  
 VT NV Mem.  
 VT RAM Mem.  
 5.0 mph  
 0.0 inH<sub>2</sub>O  
 165.6 ac  
 0.0 ac  
 0.0 lb/ac  
 100.0 lb/ac  
 29 49.9 lb/ac  
 440 psi  
 1 2 3  
 CH Global N.V. Planters/Seeders Seed Rate Control

# DISPLAY TASK CONTROLLER OPERATION – 500T

## DISPLAY TASK CONTROLLER OPERATION

Version 30.\* and after Task Controller

The “Task Controller” application allows an operator to:

- Log ISOBUS As-Applied data from the implement to the memory stick (USB data card P/N - 84398840, required for operation)
- Turn section clutches ON/OFF automatically based on field boundaries and previously worked areas.
- Use task data in the ISO Extensible Markup Language (ISO XML) format to communicate job information e.g. crop setup, product setup, worker details, prescriptions) through the display to the Precision Disk 500T.

**Note:** Task Controller will only function with 4 section drills, not for use on 2 section drills.

## Turn the Task Controller On & Enter Tractor Setup Information

1. Select Back > Toolbox > TC > TC Setup



2. Select the ‘Task Controller’ window and choose ‘Installed’. The display may need to be restarted.

3. ‘Enable’ Auto Resume. After a key cycle the TC Task will automatically resume.

4. Select Tractor Type and choose the style of tractor that is pulling the implement.

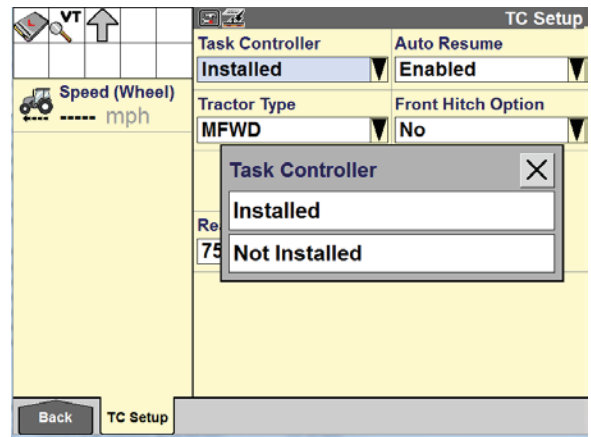
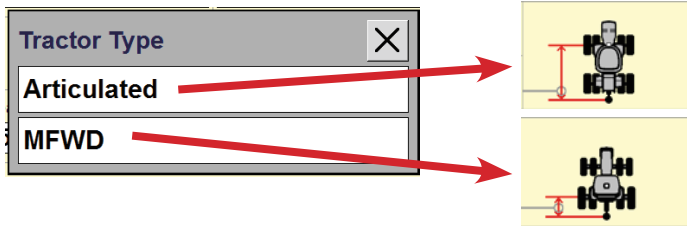

5. Measure the Rear Hitch Offset and enter the measurement in the correct units. Use the Diagrams to properly measure.

**Note:** The receiver Forward offset should also be checked (Toolbox>GPS)

**Rear Hitch Offset**

**75.0 inch**

# DISPLAY TASK CONTROLLER OPERATION – 500T

## ENTER THE DRILL PRECISION FARMING SETUP

VT > 'BACK' (to main screen) > 'SETUP' > 'PF'



**Note:** Help is available any time by pressing “i”.

1. Measure, verify and enter the 'Tool Width', 'Tool Rear Offset', 'Tool Center Offset', and 'Time Latency' values. These values will be automatically entered in to the Task Controller to be used when mapping and using automatics section control.

**TIP!** If using auto guidance, adjust the 'Tool Center Offset' to adjust for pass-to-pass spacing. See chart for settings.  
**Note:** this position is where the rank actually is.

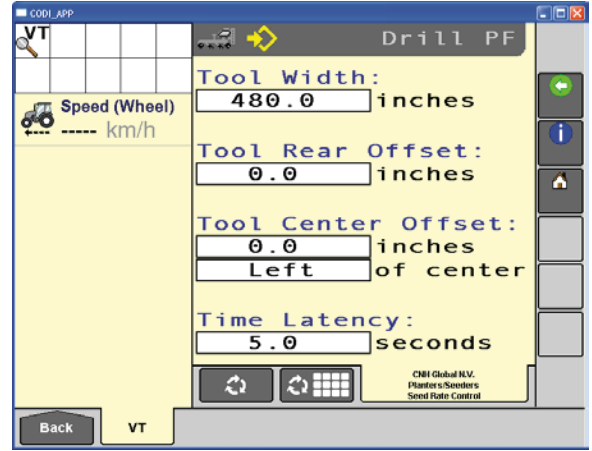

Row Spacing	Rear Rank Active	Front Rank Active
7.5 in. (seeding in 15 in.)	0 in. Offset	Left of Center 7.5 in.
10 in. (seeding in 20 in.)	0 in. Offset	Left of Center 10 in.

**Note:** The Precision Disk 500T 25 ft. 10 in. spacing is offset opposite from the dimensions in the chart. 25 ft. 10 in. should be - Rear Rank active - 0 in. of offset; Front Rank Active - Right of Center 10 in.)

**Time Latency:**  
How long it takes product to reach from ground from when the meter is commanded to turn on. Very important for section control operation!

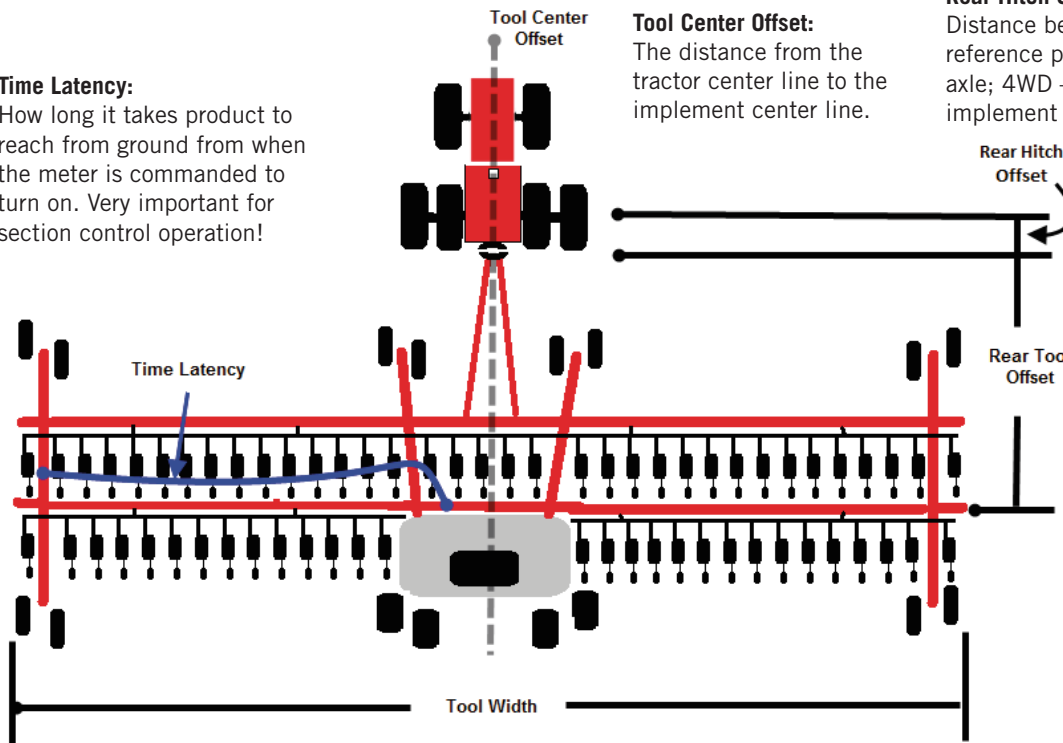

**Tool Center Offset:**  
The distance from the tractor center line to the implement center line.

**Rear Hitch Offset:**  
Distance between tractor axle reference point (MFWD - Rear axle; 4WD - Front Axle) and the implement hitch point.

**Tool Rear Offset:**  
The distance from the center of the two opener ranks

**Tool Width:**  
The working width of the drill.



# DISPLAY TASK CONTROLLER OPERATION – 500T

## CLUTCH CONTROL

A four clutch system with the Task Controller software unlocked/ installed is able to control for Global Positioning System (GPS) overlap control. Clutches that are shown with a black background are engaged. Gray shading indicates the clutch is disengaged.

Clutches control the metering sections from left to right. The clutch buttons will have a blue border and the icon will change to an A over the clutch when in a previously seeded area.

## MAPPING AND OVERLAP CONTROL SETUP

'BACK' (to main screen) > 'SETUP' > 'PF'



1. Measure and Adjust Time Latency
  - a) To determine the Time Latency:
  - b) Remove one secondary hose from an opener. Turn on the fan (Note: use the Prime button to adjust the pressure to the proper level using the open line test (seed above the hose end 12-18 in)).
  - c) Press the Prime button.
  - d) Count the number of seconds from when the prime button is pushed to when product is seen coming out of the hose. If available, stop watch can be used.
  - e) Enter the number as the Time Latency figure.
  - f) Check the operation by digging and make adjustments to Start Early/Stop Late measurements to intentionally overlap, if needed. (Toolbox>Overlap)
  - g) Throughout the season check for proper overlap operation.

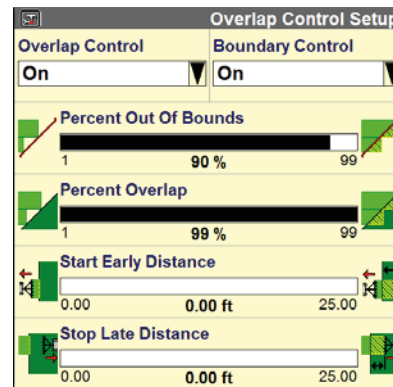
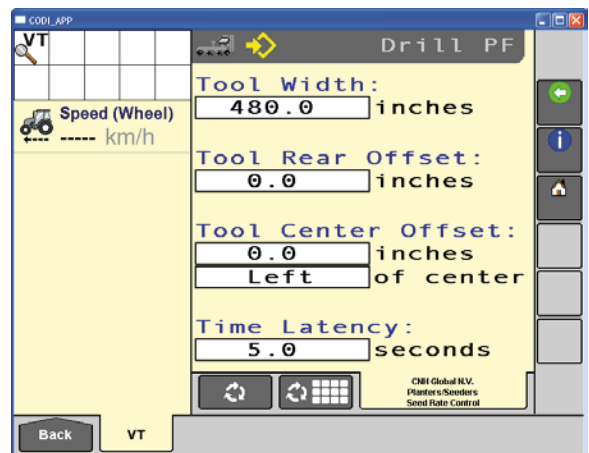
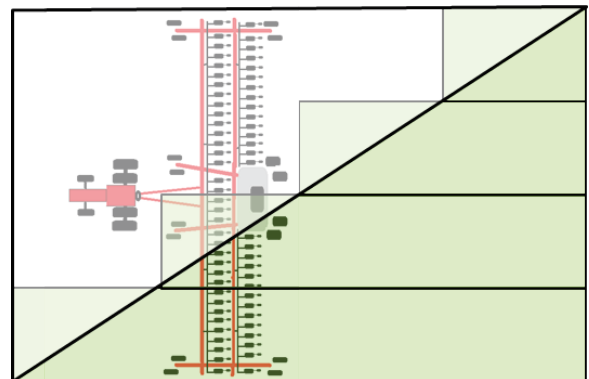
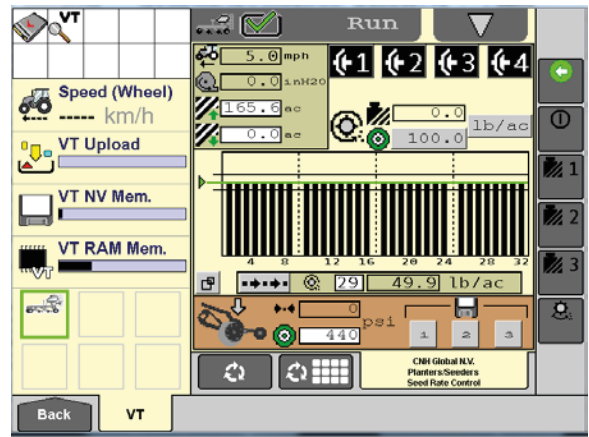

# DISPLAY TASK CONTROLLER OPERATION – 500T

## MAPPING AND OVERLAP CONTROL SETUP (continued)

### SET-UP GROWER, FARM, FIELD....

2. In the display, navigate to

'Performance' > 'TC' > 'TC Task'



3. Create new or select the TC Grower, TC Farm, TC Field, and TC Task that you'll be working in.

**TIP!** These elements (TC Grower, etc.) will automatically populate the Grower/Farm/Field hierarchy found in 'Performance>'Profile.'

**Note:** If data pre-existed in a desktop software program (ex. AFS Software Mapping & Records) and will be imported to the display, be sure that the data format is exported in the ISOXML format.

If guidance lines, boundaries, or obstacles are needed, they must be exported in Voyager 2 format.

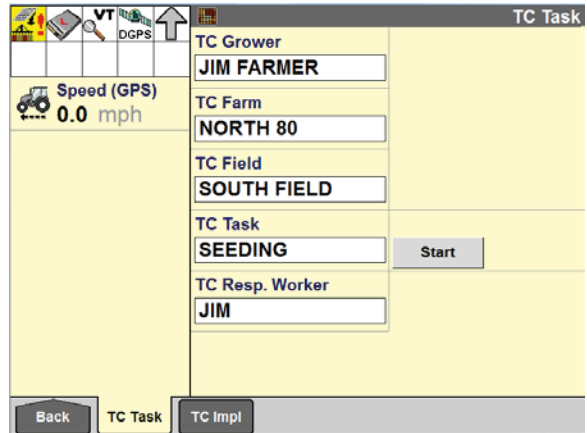

### SELECT IMPLEMENT

4. Select the TC Implement to be used with this Task ('Performance' > 'TC' > 'TC Impl').

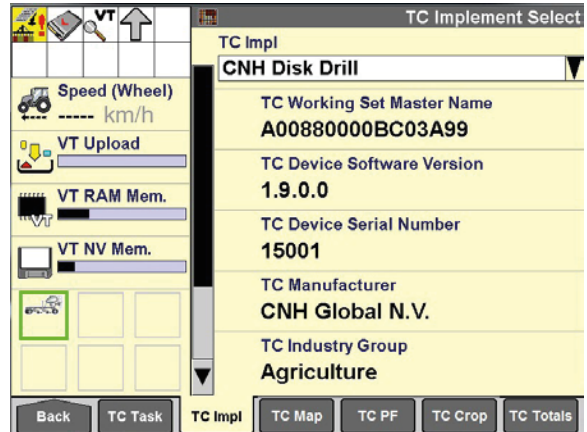

### MAP LAYER AND PRESCRIPTION ASSIGNMENT SET-UP

'Performance' > 'TC' > 'TC Map'

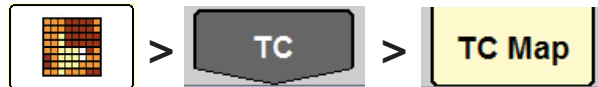

5. Check that TankIMass Per Area actual) is assigned to a TC Map Layer. (Map Layer 1 is suggested).

This map layer of applied rate will be viewable on the Run Screen where 'Map' window is located.

Assign a prescription to the map layer 1 if required (4 section drills only!). See quick reference card AFS-8092-14 for more information on creating a prescription for the ISO TC.

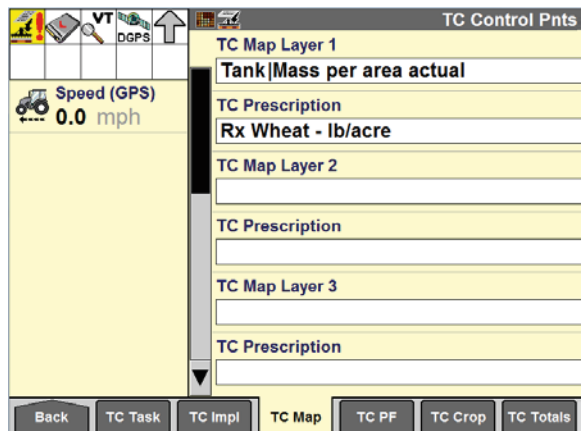

# DISPLAY TASK CONTROLLER OPERATION – 500T

## MAPPING AND OVERLAP CONTROL SETUP (continued)

### IMPLEMENT MEASUREMENTS

6. Navigate to 'Performance' > 'TC' > 'TC PF'.



7. Verify the Implement width, swath width and Implement Offset.
8. The values on the left are from the implement ECU.
9. The values on the right are your override values.

**Note:** Forward offset values are adding in the measurement from the tractor reference point to hitch.

**TIP!** The Left Hand values in 'TC PF' are adjusted in the implement Virtual Terminal (VT>Setup>PF). Assure those values are correct before making adjustments 'TC PF'. See page 24 for details on adjusting clutch control/product delay performance.

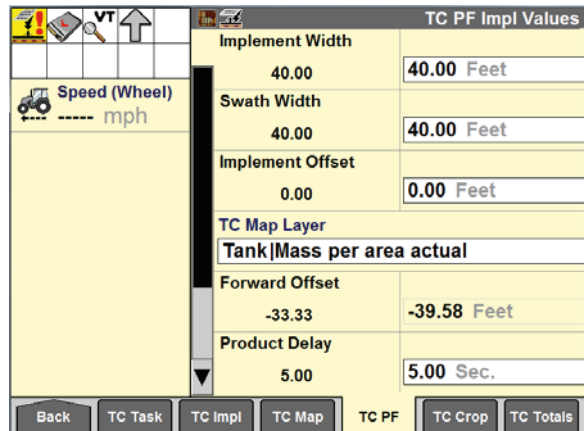

## VARIETY TRACKING

(v30.\* and after Task Controller)

Variety Tracking is available to map varieties or different products controlled by the Task Controller. The following steps will properly set-up the task controller for variety tracking. This information can be imported in to the AFS Software program for tracking yield and moisture information during harvest.

1. Select 'Performance' > 'TC' > 'TC Crop'



2. Select 'TC Crop' window at the top of the screen and press 'Select' (if choosing a pre-existing crop type) or 'Add New' (if the crop types are not available). Enter the Crop Type to be seeded. Repeat as need for additional Crop Types

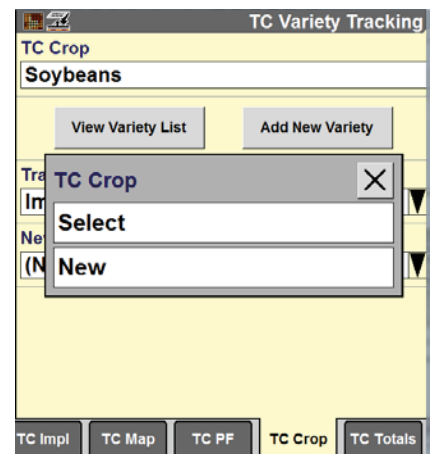

# DISPLAY OPERATION – 500T

## VARIETY TRACKING (continued)

3. Select Add New Variety and enter the Variety Name. Press Enter once completed. Repeat as need for additional Varieties.



4. Select what level of tracking is desired.
  - Implement** – one variety; Full Width of implement (PD500T)
  - Boom** – Different Variety per section/meter (Precision Air Cart)
  - Section** – Different Variety Per Row (Not Recommend for Seeding)

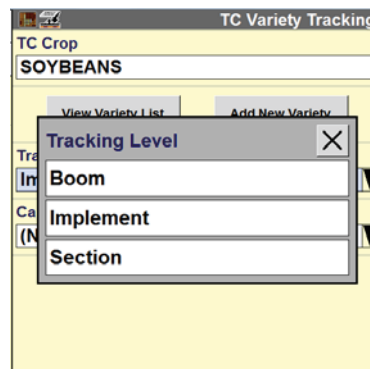

5. Choose the Variety

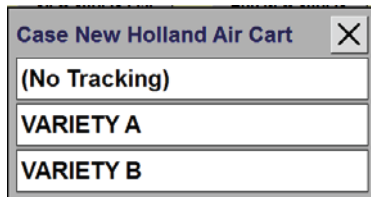

6. The TC Crop Type, Tracking Level and Variety are always shown and can be changed at any time.

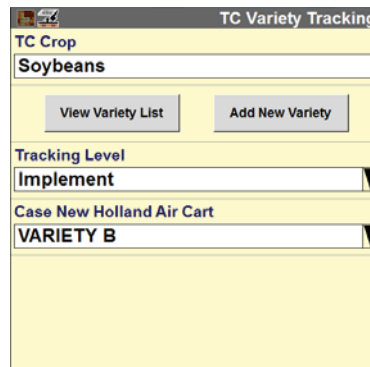

## START TASK

'Performance' > 'TC' > 'TC Task'



7. Press 'Start' or 'Resume' if the task has not been started.



**TIP!** If the Task has not been started, a warning icon will flash in the upper left hand corner area.

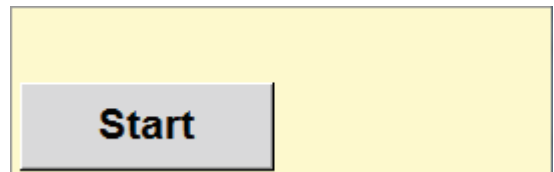

# DISPLAY TASK CONTROLLER OPERATION – 500T

## OVERLAP/BOUNDARY CONTROL OPERATION

- If using Automatic Overlap Control (4 section drill only) place the Overlap Control Window on a run screen to easily turn Overlap Control on and off. If the button is black, the overlap control is in Automatic mode.
- If pre-recorded boundaries are available, place the Boundary Control Window on a run screen to easily turn Boundary Control on and off. If the button is black, the Boundary Control is in Automatic mode.
- When overlapped in a previously seeded area or outside of a boundary, this icon will be shown in the top left hand warning/ icons area. This notifies the operator that a section is not applying product.
- If viewed on the Disk Drill Run screen, the clutch buttons will have a blue border and the icon will change to an A over the clutch when a previously seeded area.

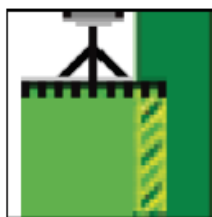
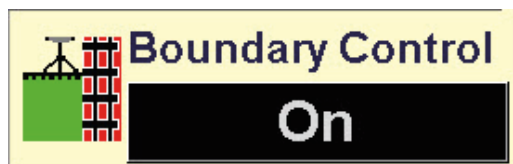
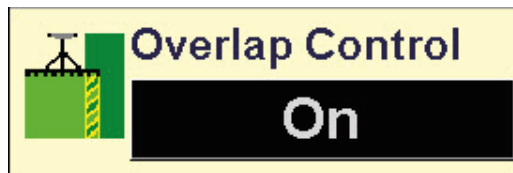

# PREPARE FOR STORAGE

## PROPER STORAGE

Proper drill storage practices are a key element in maintaining your drill's accuracy and efficiency. Refer to the Precision Disk 500 Operator's Manual for specific steps to secure your machine for storage.

1. Set storage locks as specified in the Operator's Manual. Park the planter on appropriate storage stands.
2. Make sure tires are properly inflated.
3. Turn Fan on and assure no seed is left in the delivery hoses.
4. Drain all seed from the tank. A flexible clean-out tube is available from parts, part number 47710042.
5. Disconnect hydraulic and electrical lines. Cover connectors to prevent dirt contamination during storage.
6. Remove and clean seed meter. Inspect parts for wear.
7. Coat exposed hydraulic cylinder rods with grease to prevent rust.
8. Clean ground-engaging parts, and coat with grease or Case IH TILCOAT to prevent rust during storage. (Purchase TILCOAT from your Case IH dealer in aerosol, part number 1132221N, or in larger bulk containers).
9. Remove drive chains and store in a container of clean oil or diesel fuel.
10. Clean and lubricate the Disk Drill. Use touch-up paint as necessary.
11. Check ground engaging components for wear, and replace as needed.
12. Inspect electrical harnesses and hydraulic hoses. Make necessary repairs to worn or damaged areas.
13. Clean and inspect the air/seed delivery system.
14. Check and re-tighten hardware.



# PREPARE FOR STORAGE

PRECISION DISK PRODUCTIVITY TIPS





SAFETY NEVER HURTS!™ Always read the Operator's Manual before operating any equipment. Inspect equipment before using it, and be sure it is operating properly. Follow the product safety signs, and use any safety features provided. CNH America LLC reserves the right to make improvements in design and changes in specifications at any time without notice and without incurring any obligation to install them on units previously sold. Specifications, descriptions and illustrative material herein are as accurate as known at time of publication, but are subject to change without notice. Availability of some models and equipment builds varies according to the country in which the equipment is used.

©2015 CNH Industrial America LLC. All rights reserved. Case IH is a trademark registered in the United States and many other countries, owned by or licensed to CNH Industrial N.V., its subsidiaries or affiliates.

Printed in U.S.A. [www.caseih.com](http://www.caseih.com)

PL-3102-15