



# NEW HOLLAND T3F

T3.55F | T3.65F | T3.75F





## THE NEW LIGHTWEIGHT COMPACT TRACTOR FOR PROFESSIONAL FRUIT GROWERS

New Holland has a long tradition of excellence and consolidated leadership in the production of specialised orchard tractors. Designed and built to meet the needs of professional fruit growers seeking a compact machine offering exceptional performance in the power range from 55 to 72hp, the new T3F series tractors can move with ease between rows, offering excellent performance for spraying, cultivation and road transport. In addition, these machines continue the New Holland tradition of ergonomic excellence, by providing the operator with a comfortable working environment with simple and intuitive controls. In the field of compact orchard tractors, there's only space for New Holland between your rows.





#### POWERFUL AND COMPACT

Powered by lively three-cylinder turbocharged and inter-cooled engines, with the flagship T3.75F model producing 72hp, the T3F tractor series offers unrivalled performance in a compact package.



#### SPECIALIST VERSATILITY

Few specialist tractors can match the all-round versatility of a T3F tractor. Light weight and compact dimensions give this tractor the edge when working in confined spaces such as orchards and vineyards.



#### PRODUCTIVE COMFORT

Class leading ergonomics define this tractor. Ensuring operators are comfortable during long working days was a top design priority, and is apparent from the thoughtfully laid out controls.



#### HYDRAULIC SUPERIORITY

The T3F is well equipped in terms of hydraulics, boasting a lift capacity of 2277kg, aided by two external lift rams, and a separate pump for hydraulics and for steering. The user friendly Lift-O-Matic™ system makes rear linkage operation quick and simple.



## THE LAST WORD IN ERGONOMICS AND OPERATOR COMFORT

The suspended platform of the new T3F machines assures perfect noise and vibration isolation, and supports an operator environment featuring unbeatable comfort, ergonomics and ease of use. From the generously sized adjustable seat the operator enjoys perfect visibility on all sides of the machine and a clear view of the implements. All controls are positioned logically and within easy reach. The clear and intuitive instrument panel provides key information concerning the main operating parameters at a glance. The practical shuttle lever allows smooth direction changes. Everything is designed to reduce fatigue, maximise workrates and boost productivity. Typically New Holland.





### CONTROLS RIGHT WHERE YOU NEED THEM

Nearly all major control levers are positioned on the right hand side of the cab platform. The gearstick is mounted conveniently and within easy reach, to make the most efficient use of space, the hydraulic levers are cleverly positioned on the right hand fender for a clutter free operator environment.



### ADVANCED DESIGN

A concealed muffler and air intake ensure unobstructed visibility over the sloping bonnet. The ROPS frame can also be folded down completely to eliminate any forward visibility impairment, with clear benefits in orchards and vineyards, where rounded profiles are needed to reduce the risk of crop damage. Another novel feature of these tractors are the suspended foot pedals, which allow for easier operation and clutter free footwells.





## CLEAN PERFORMANCE. RESPONSIVE PRODUCTIVITY.



*Sustainable Efficient Technology*

All models of the new T3F series are equipped with FPT Industrial S8000 turbocharged and intercooled engines with rated power of 55, 65 and 72hp at 2300rpm. These tough and well proven power units demonstrate impressive performance, delivering peak torque at low rpm, while being simple and cost effective to maintain. Compact and responsive, these primarily mechanical 2,9 litres, 3-cylinder engines are in compliance with Tier 3A emissions legislation, produce low noise and vibration levels, are compatible with 100% biodiesel blend, and provide excellent fuel economy.







### EXTENDED OPERATION

Thanks to the generous 50l fuel tank combined with reduced fuel consumption, T3F series tractors can work tirelessly for prolonged periods without refuelling.

# A WIDE CHOICE OF EFFICIENT TRANSMISSIONS

## FLEXIBLE TRANSMISSIONS FOR EVERY NEED

The result of a painstaking study into customers' needs, the Synchro Shuttle™ transmission is available in 12x12 versions at up to 30 or 40kph and 20x20 up to 40kph with creeper. Thanks to the inching speeds of the creeper, the new T3F can proceed at just 0.10kph, ideal, for example, for specialist planting applications. For intensive PTO applications, forward speeds as low as 0.2kph can be achieved.

	<b>12x12</b> Synchro Shuttle™ (30 kph)		<b>12x12</b> Synchro Shuttle™ (40 kph)
	<b>20x20</b> Synchro Shuttle™ (optional Creeper / 30 kph)		<b>20x20</b> Synchro Shuttle™ (optional Creeper / 40 kph)

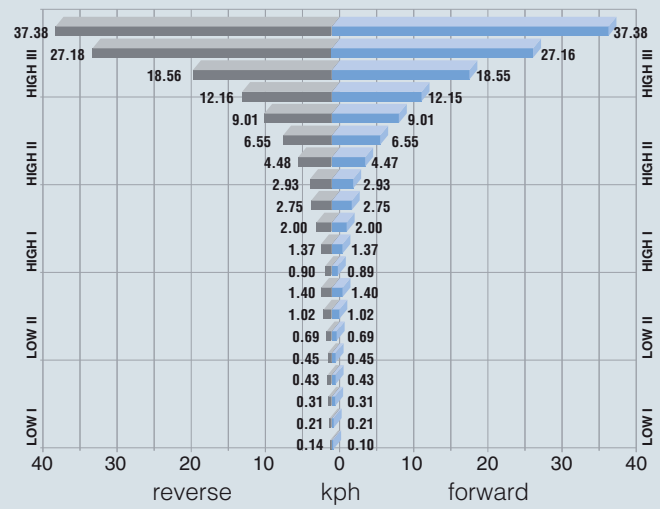

## SMOOTH DIRECTION CHANGE

The Synchro Shuttle™ system makes direction changes fast and easy without using the gear shift. The operator just uses the dedicated shuttle lever and clutch. The result? Seamless direction changes, better comfort and more productivity.

## OPTIMISING TRACTION

All models are equipped as standard with electro-hydraulic engagement of four-wheel drive and locking of the rear differential. The front axle benefits from a limited slip differential lock, while the rear axles final planetary gears are housed internally within the bell housing, a modern design concept for increased strength and durability.



# COMPACT DIMENSIONS, EXCEPTIONAL FEATURES, PREMIUM PERFORMANCE



Lighter and shorter than the award winning specialised T4000F/N/V series tractors, the new T3F machines are on a par with their “big brothers” in terms of features. Hydraulic rear hitch with two external hydraulic rams, lift capacity of 2277kg and Lift-O-Matic™ system supplied as standard. Two separate pumps for the hydraulic circuit and steering. Up to 3 remote valves. Servo-assisted PTO with up to 3 speeds.

## TURN TIGHTER FOR GREATER PRODUCTIVITY

New Holland tractors are recognised as offering class-leading manoeuvrability. And the T3F series is no exception. Thanks to the wheelbase of 186cm the tractor can offer a turn radius as low as 3.4m.

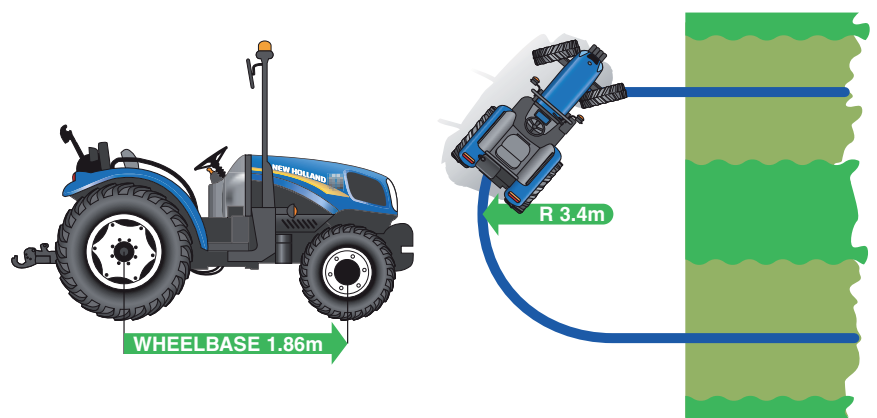





### **MECHANICAL HYDRAULICS WITH THE LIFT-O-MATIC™ SYSTEM**

The mechanically operated hydraulic hitch, specifically designed for the T3F series, is equipped with two external hydraulic rams to combine the slim profile with an impressive 2277kg lifting capacity. The Lift-O-Matic™ system is standard and enables an implement to be raised and lowered to its previous setting using a single control on the right-hand console. Quick attach couplings serve to simplify the implement attachment process.



### **WIDE CHOICE OF PTO SPEEDS**

All T3F models are equipped as standard with two PTO speeds: 540 and 540E. A 3-speed version; 540, 540E and proportional groundspeed is available as an option. The speed selector is located on the console. PTO engagement is controlled by a servo-assisted lever that reduces the operating pressure required to engage the clutch, making it a simple task to manually modulate power fed to the implement.



### **HYDRAULIC POWER FOR EVERY NEED**

T3F series tractors are equipped as standard with a 52l/min hydraulic pump. The tractors also feature a second independent 32l/min steering pump so the main pump will always deliver its full capacity regardless of the load on the steering circuit. All models can be specified with up to 3 remote hydraulic valves.





MODELS	T3.55F	T3.65F	T3.75F
<b>New Holland Engine</b>	S8000 Series	S8000 Series	S8000 Series
N. of cylinders / Valves	3 / 2	3 / 2	3 / 2
Emissions level	Tier 3/Stage 3A	Tier 3/Stage 3A	Tier 3/Stage 3A
Capacity (cm <sup>3</sup> )	2930	2930	2930
Air Intake	TCA	TCA	TCA
Intercooler	●	●	●
Approved biodiesel blend	B100	B100	B100
Rated engine power ISO TR14396 - ECE R120 [kW/hp(CV)]	40.4/55	47.8/65	53/72
Rated engine speed (rpm)	2300	2300	2300
Max. torque - ISO TR14396 (Nm)	220 @ 1400rpm	261 @ 1400rpm	295 @ 1400rpm
Torque rise (%)	29.4	34.5	34.1
Horizontal exhaust	●	●	●
EGR system for internal exhaust gas recirculation	●	●	●
Cooling	Liquid	Liquid	Liquid
Optimal fuel consumption (g/kWh)	238	238	235
Standard diesel tank capacity (Litres)	50	50	50
<b>Gearbox</b>			
Rear electro hydraulic diff. lock	●	●	●
Oil immersed braking system	●	●	●
<b>12x12 30kph- Mech Shuttle</b>	●	●	●
Minimum speed (without creeper) (kph)	0.73	0.73	0.73
<b>20x20 (12x12 creeper version) 30kph- Mech Shuttle</b>	○	○	○
Minimum speed (with creeper) (kph)	0.10	0.10	0.10
<b>12x12 40kph- Mech Shuttle</b>	○	○	○
Minimum speed (without creeper) (kph)	0.89	0.89	0.89
<b>20x20 (12x12 creeper version) 40kph- Mech Shuttle</b>	○	○	○
Minimum speed (with creeper) (kph)	0.12	0.12	0.12
<b>Front axle</b>			
4WD Front axle	●	●	●
Turn radius 4WD front axle (mm)	3400	3400	3400
Limited slip differential locking	●	●	●
Axle oscillation (°)	11	11	11
<b>Hydraulics</b>			
Standard pump flow (Lpm)	52	52	52
Steering pump (Lpm)	32	32	32
Mechanical draft control (MDC)	●	●	●
Lift-O-Matic™ system	●	●	●
Max lift capacity at ball ends with arms horizontal (kg)	2277	2277	2277
Rear linkage category I e II with quick attach couplers	●	●	●
Max. number of rear remote valves	3 (6 couplers)	3 (6 couplers)	3 (6 couplers)
<b>PTO</b>			
Servo-assisted engagement	●	●	●
Ground speed	○	○	○
540 / 540E rpm	●	●	●
<b>Operator environment</b>			
Suspended platform (with mid mounted foldable ROPS)	●	●	●
<b>Weights*</b>			
Total weight (kg)	2200	2200	2200

● Standard ○ Optional \* with 200/70R16 - 320/70R20 tyres



**DIMENSIONS\***

		<b>T3.55F</b>	<b>T3.65F</b>	<b>T3.75F</b>
Rear tyres: min		320/70R20	320/70R20	320/70R20
max		360/70R24	360/70R24	360/70R24
Front tyres: min		200/70R16	200/70R16	200/70R16
max		280/70R16	280/70R16	280/70R16
<b>A</b> Front axle ground clearance	(mm)	215	215	215
Ground clearance*	(mm)	235	235	235
<b>B</b> Overall width: min	(mm)	1350	1350	1350
max	(mm)	1710	1710	1710
<b>C</b> Wheelbase	(mm)	1863	1863	1863
<b>D</b> Length	(mm)	3438	3438	3438
<b>E</b> Steering wheel height	(mm)	1235	1235	1235
<b>F</b> Overall height	(mm)	2246	2246	2246
<b>G</b> Seat height	(mm)	995	995	995

\* with 200/70R16 - 320/70R20 tyres





# NEW HOLLAND TOP SERVICE: CUSTOMER SUPPORT AND CUSTOMER INFORMATION



## TOP AVAILABILITY

If you need information, or have an out of hours question, ring our toll-free number\*. All day, every day, we are just a call away.



## TOP SPEED

Express parts delivery: when you need it, where you need it!



## TOP PRIORITY

Fast-track solution during the season: because your harvest can't wait!



## TOP SATISFACTION

We drive and track the solution you need, keeping you informed: until you are 100% satisfied!



**For more details, ask your New Holland dealer!**

\* Calls to the Top Service team are free from landlines in the United Kingdom and Republic of Ireland. UK-based mobile calls are also free, but Republic of Ireland mobile users should call **01 2421881** and this will be charged at your standard network rate.

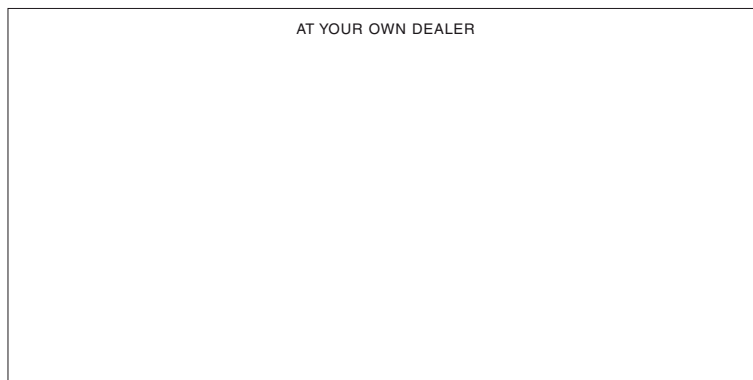

Experience New Holland What's App!  
Scan here to download the Apps



[www.newholland.com/uk](http://www.newholland.com/uk) - [www.newholland.com/ie](http://www.newholland.com/ie)

The data indicated in this folder are approximate. The models described here can be subjected to modifications without any notice by the manufacturer. The drawings and photos may refer to equipment that is either optional or intended for other countries. Please apply to our Sales Network for any further information. Published by New Holland Brand Communications. Bts Adv. - Printed in Italy - 10/15 - TP01 - (Turin) - 140001/INB

New Holland with

