

## WHEEL LOADERS

WI10D / WI30D / WI50D / WI70D / WI90D



**WORK SMART  
AND MOVE MORE.**



# CONSTRUCTION POWER. INDUSTRIAL PRODUCTIVITY.

New Holland D-Series wheel loaders are developed from machines proven in the toughest quarries, 24-hour recycling plants and countless intensive industrial applications, and deliver tough, versatile and reliable performance. The latest D series wheel loaders now deliver more, with an all-new, best-in-class cab for improved visibility and unrivalled levels of comfort in addition to a range of new features to improve productivity.

The new touchscreen colour display hosts features such as a new integrated payload scale, new fuel saving engine work modes, tyre pressure monitoring and hydraulic aggressiveness settings. The three new armrest mounted configurable short-cut buttons allow operators to tailor their set up, so they can quickly access their most frequently used functions. On the outside, parallel lift technology is now available as standard on all Z-bar models and is no longer exclusive to Tool Carrier machines. The upgraded lighting package features additional rear LED lights integrated into the grill to give an overall output of an impressive 43,000 lumen. Operator comfort and convenience aren't the only things that have been improved, service intervals have now doubled to 1000 hours, halving your service time and reducing maintenance costs by up to 20%. New Holland wheel loaders have always offered exceptional levels of strength, performance and reliability. Now they offer exceptional levels of comfort, versatility, technology and economy to make them the operator's first choice.

Two engine working modes

Best in class cab

Standard or Long Reach booms

Adjustable hydraulic responsiveness

Tool Carrier parallel linkage boom option on W110 D, W130 D, W150 D & W170 D

Z-bar booms feature parallel lifting as standard

Bucket shake function

Fully integrated payload scale

Heavy-duty axles as standard on top four models

Z-Bar linkage with self levelling

\* on W130 D, W150 D & W170 D where local homologation allows



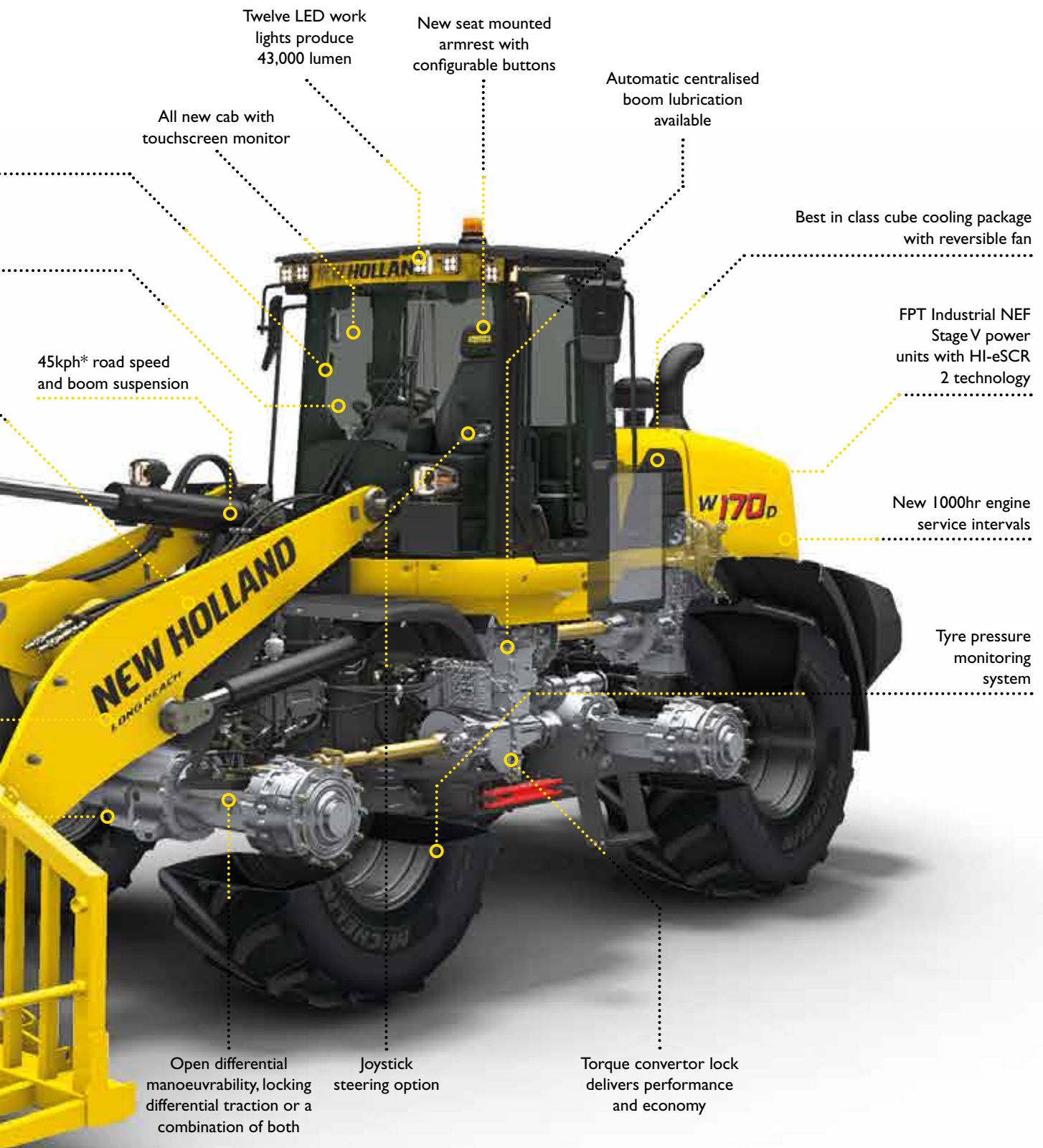

MODELS	ENGINE POWER (HP)	Operating Weight Z-bar / LR / TC (kg)*	Tipping load straight Z-bar / LR / TC (kg)*
W110 D	142	11303 / 11431 / 11546	8418 / 7184 / 7161
W130 D	172	13330 / 13512 / 13376	10134 / 8464 / 8826
W150 D	172	14515 / 14696 / 14446	11400 / 9568 / 9740
W170 D	195	16127 / 16330 / 15863	12069 / 10204 / 10587
W190 D	230	19397 / 19665 / -	13162 / 10420 / -

\* weights quoted **with Quick Coupler option & bucket with bolt on edge**

# EFFICIENCY WITHOUT COMPROMISE.



Powered by 4.5L and 6.7L NEF High Efficiency Selective Catalytic Reduction HI-eSCR 2 engines, New Holland W110 D, W130 D, W150 D, W170 D and W190 D wheel loaders combine proven dependability and class leading economy. Compliant with Stage V emission regulations, the NEF power units have been co-developed with New Holland sister company FPT Industrial, the pioneer of common rail fuel injection and producer of SCR power units proven in agriculture, transport and industry for over 10 years. The latest ECOBlue and HI-eSCR 2 technology employs a newly developed electronic control unit that manages both the engine and the HI-eSCR exhaust to precisely match engine load, emissions and after-treatment. Using a dedicated closed loop system to continuously monitor NOx levels in the exhaust, HI-eSCR precisely monitors the flow of AdBlue. This will achieve more than 95% NOx conversion with minimised AdBlue usage. What's more, the HI-eSCR 2 system does not utilise a DPF or need to regenerate, so achieves a much lower maximum operation temperature, a critical factor when working with dry flammable material such as wood chips.



## OPTIMUM WEIGHT DISTRIBUTION

New Holland has engineered the D series wheel loader with the engine mounted far behind the rear axle, optimising the weight balance, eliminating the need to add extra “dead” weight. This approach also allows unhindered ground level access to the engine service points as there are no stacked radiators to get in the way. Due to the clean running characteristics of the power unit, engine oil change intervals are set at 1000 hours.

## UNIQUE COOLING PACKAGE

- A key design feature of D series loaders is the positioning of the engine behind the rear axle, with a cooling ‘cube’ between the engine and transmission
- The programmable reversible fan option forces air through each of the five main radiators individually, ensuring each one benefits from a direct flow of cool air
- Hot air is not passed between each radiator, reducing the load on the cooling fan which in turn reduces power consumption





#### Selectable engine work modes

Choose from two different engine modes to tailor engine output to your requirements for maximum efficiency and fuel savings.

- **Max mode:** optimises the the engine power and transmission to deliver maximum power, torque and acceleration for aggressive pushing and climbing.
- **Smart mode:** manages the engine and transmission performance to optimise fuel efficiency, reducing fuel use by up to 10%. Smoother gearshifts and increased operator comfort make it ideal for loading applications.



# UNMATCHED DURABILITY IN THE TOUGHEST ENVIRONMENTS

---

New Holland has engineered the D Series wheel loaders to suit handle all types of bulk materials. D Series wheel loaders also have the traction to work extremely muddy conditions. These machines are designed with maximum productivity in mind.

## POWERSHIFT TRANSMISSION WITH TORQUE CONVERTER

- The full model range offers options for either a 4-speed or 5-speed Ecoshift PowerShift transmission with a torque converter
- Auto-shifting and kick-down functions come standard across all models
- 5-speed transmission includes a 'power-inch' function, the transmission delivers optimised pushing power whilst eliminating roll back
- The 4-speed transmission is equipped with the Intelligent Declutch System as a standard feature. When braking, the system redirects full engine power to the hydraulics, ensuring maximum loading performance
- On all models, the forward reverse shuttle can be operated via a steering column mounted lever or by forward / reverse buttons on the joystick
- To speed load cycles, releasing the drive pedal will bring the loader to a stop without the need to use the brakes. Even on an incline, there will be no roll back

\* 50kph with Michelin Mega X-bib 750/65R26, where homologation allows



## REAR AXLE OSCILLATION

- Rear axle oscillation is not a compromise. Stability is ensured even when traversing uneven terrain or large debris, providing reliable performance during material handling and compaction tasks in construction environments

## HEAVY DUTY AXLES

- W150 D, W170 D & W190 D models feature a broad differential offering and Heavy Duty axles as standard:
  - Choose from either LSD front and rear for soft changeable conditions
  - 100% locking front and open rear for straight pushing
  - or the best of both worlds in the form of the 100% locking front diff and LSD on the rear axle
- W110 D models are equipped with Standard Duty axles and LSD front and rear
- W130 D models are equipped with 100% locking front diff and open rear on Heavy Duty axles
- The front differential can also be manually activated by a foot switch or configurable armrest button
- Heavy duty axles with front differential lock result in 20-30% less tyre wear and lower fuel consumption overall





### **TRANSMISSION KICKDOWN**

- All models have a transmission 'kickdown' feature activated by a button on the joystick
- This feature provides quick access to a lower gear to optimise power when climbing or pushing



### **DURABLE RUBBER STOPS**

- Durable replaceable rubber blocks absorb the impact of the chassis articulation points meeting at full steering lock
- Noise, shock and vibration is reduced as a result



### **TYRE PRESSURE MONITORING**

- A sensor on each wheel monitors the tyre pressure
- The driver is alerted on the touchscreen if pressure drops below range
- Correct tyre pressure is critical to reducing fuel consumption and tyre wear and minimising downtime and operating costs



# ERGONOMIC PERFECTION.

---

Purpose designed for the D series wheel loaders, the new generation cab offers class leading all-round visibility, comfort and operator security. Fully FOPS and ROPS certified, the new cab features a curved, one-piece windscreen offering a clear and uninterrupted view of the loader arm, with an excellent view to the front as the boom is raised. Visibility over the shoulder, to the sides and extremities is excellent, allowing the operator to place the machine accurately and with confidence in confined areas. The seat mounted joystick control features a fully adjustable armrest, and the redesigned side console ensures all key functions are always within easy reach. Stay properly connected thanks to the Bluetooth radio with ceiling mounted microphone and remote AUX and USB sockets in the side console. The advanced ventilation package ensures the cab remains comfortable regardless of outside temperatures, with excellent filtration allowing operation in dusty environments. To further aid comfort, the cab is mounted on purpose designed viscous oil suspension blocks to reduce noise and vibration and results in noise levels as low as 68dB(A).



## LUXURY SEAT OPTION

- Operators working over rough terrain, silage clamps and spending long hours in the cab can specify a deluxe seat with automatic weight adjustment, high visibility seatbelt, half leather trim, low frequency shock absorption system, headrest and heating



## EXCELLENT VENTILATION

- Thirteen adjustable vents keep you comfortable and the cab glass clear
- A grid defroster takes care of the rear window in cold conditions





#### **FINISHING TOUCHES**

- Dual internal cab mirrors and front and rear sun blinds increase safety and help reduce blindspots
- Right side window can be locked fully open to allow easy communication with people on the ground



#### **KEEP IT COOL**

- Optional 30 litre portable coolbox keeps your drinks and snacks cool all day



#### **CAB FILTRATION**

- The cab filter cartridge combines high levels of filtration with generous capacity to allow extended periods between renewal
- There is a choice between the standard CAT2 HVAC or a CAT3 Activated carbon filter can be ordered separately through CNH parts
- The filtration system is linked to an advanced heating and air-conditioned ventilation package

# CONTROLS.

---

The D series wheel loaders have a new armrest and joystick design that has been developed to considerably reduce operator fatigue. The angle of the operators arm to the body has been carefully considered to minimise strain on the joints and not to compromise blood flow. Full seating support ensures good posture is maintained. Three new armrest mounted configurable short cut buttons make the operators preferred frequently used functions more easily accessible. The result? Less fatigue and benefits for the operator's long term health.



## NEW SEAT MOUNTED ARMREST

- Fully adjustable seat mounted armrest and arm cushion
- Armrest can slide horizontally independently of the seat for maximum comfort
- Armrest cushion can move vertically





### NEW TOUCHSCREEN DASHBOARD DISPLAY

- New touchscreen, 8inch LCD colour display provides the operator with a digital dashboard on the A pillar
- Tap and scroll through various menus to include machine information, service settings and reminders or even the operators manual
- Set a variety of working parameters such as starting gear, flow rates and engine modes
- When reverse is selected, the display will automatically show the rear camera view
- The display is anti-glare and automatically switches between day and night modes



### CONFIGURED FOR YOU

- Three new configurable buttons on the armrest allow you to tailor your controls through the touchscreen
- Ergonomic position provides quick access to the most frequently used functions
- Configure different functions relative to different screen pages: home screen or payload screen
- Configurable functions include: diff lock engagement, camera, beacon, engine work mode, tare zero, new ticket



### SPOILED FOR CHOICE

- New joystick features FNR, auxiliary service and transmission kickdown functions as standard
- A 2nd auxiliary function can be specified on the joystick



### EVERYTHING WITHIN EASY REACH

- New side console features a neat button cluster keeping everything within easy reach
- Grouped and colour coded, the buttons feature lights to indicate if the function is active
- Rubber lined storage trays, two cup holders, storage net, remote AUX jack & USB sockets and 12 volt power sockets are standard



### DIFFERENTIAL LOCK & THROTTLE LOCK

- Differential lock is activated by a floor mounted electronic foot switch to the left of the brake pedal
- Large pedals are ergonomically positioned for brake and accelerator functions
- Alternatively, differential lock can be activated by one of the freely configurable buttons on the armrest
- The new throttle lock feature allows a target engine speed to be set for jobs like snow blowing and sweeping



# RAISING THE STANDARD.

---

New Holland W110 D, W130 D, W150 D, W170 D and W190 D wheel loaders are fitted as standard with the mighty Z-bar linkage boom, constructed from 45mm thick plate steel. The choice between Standard and Long Reach booms enables the machine to be specified to meet different handling priorities. On W110 D, W130 D, W150 D & W170 D models, the high visibility Tool Carrier parallel lift boom option is now available.

## SELF LEVELLING Z-BAR LINKAGE

In applications where digging and pushing performance as well as high breakout force are paramount, the Z-bar linkage is the natural choice. In addition, fewer moving parts simplify daily maintenance. Parallel lifting is now available as standard on Z-bar booms, so you get the best of both worlds, high breakout force with self levelling capability. Z-bar linkage loaders are offered with a choice of boom length:

### • STANDARD BOOM

In demanding applications, the high-strength standard boom is ideally suited for working with heavy-duty attachments such as rock buckets, material handling forks, and debris pushers

### • LONG REACH BOOM

The Long Reach boom increases dump heights by 400 to 500mm, making it the ideal choice for rehandling duties such as material stockpiling, waste management, vehicle loading, and site clearance. It retains the exceptional strength of the standard boom, ensuring durability in demanding tasks





### **TOOL CARRIER LINKAGE**

In applications that require high visibility and self levelling capability, such as pallet handling using forks and specialist attachments, the Tool Carrier linkage is the best choice and comes as standard with the hydraulic quick coupler for attachment versatility. Tool Carrier linkage option is available on W110 D, W130 D, W150 D & W170 D models



# WATCHING YOUR WEIGHT.

Whether you're loading materials into a crusher, stockpiling soil or gravel, or loading trucks with construction aggregates, it's always beneficial to accurately know and record the quantities of material you're handling, especially if you're a contractor getting paid by the ton. New Holland D series loaders are now available with a fully integrated factory-fit payload scale, removing the guesswork from any loading task and ensuring maximum return on your investment.



## AUTOMATIC BOOM FUNCTIONS

- Lift to a predetermined height
- Return to a pre-set dig level
- Raise the boom to a set height for travel / cycling between load and dump
- Ride Control boom suspension with speed adjustment feature
- Bucket shake function



## HYDRAULIC FLOW ON DEMAND

- Closed centre load sensing hydraulics are standard, the W170 D and W190 D benefitting from tandem pumps for increased capacity
- A key element of the New Holland design is efficiency, the pumps delivering the required hydraulic flow upon demand
- When the brake pedal is pressed, full engine power is made available to the hydraulics but the system will only demand extra power as required for the task, adjusting flow in accordance with demands, for fast boom raise/lower or attachment crowd/dump

MODEL		Hydraulic pump capacity
W110 D	(l/min)	134
W130 D	(l/min)	169
W150 D	(l/min)	190
W170 D	(l/min)	206
W190 D	(l/min)	236



## CENTRALISED GREASE POINTS

- Where possible, all grease points are grouped together
- The optional auto lubrication system ensures regular and metered lubrication to reduce whole life operating costs
- Automatic lubrication system features an in-cab switch to activate a manual greasing cycle





### AUTOMATIC PAYLOAD SCALE

The automatic payload scale uses the new touchscreen display to precisely weigh materials in real time during loading. It offers a range of features that streamline record-keeping and management, such as the ability to store customer details, vehicle registrations, material types, and bucket sizes. This system simplifies tracking, allowing operators to input relevant data directly on the touchscreen, and print load tickets on-site once the job is complete. This not only enhances operational efficiency but also ensures accurate billing and load management, critical for maximising productivity.

- Easy to calibrate
- 98% + accuracy
- Target loading mode
- Auto loading mode
- Configurable armrest button functionality
- Slope correction
- Hydraulic oil temperature compensation
- Z-bar & Tool Carrier compatible

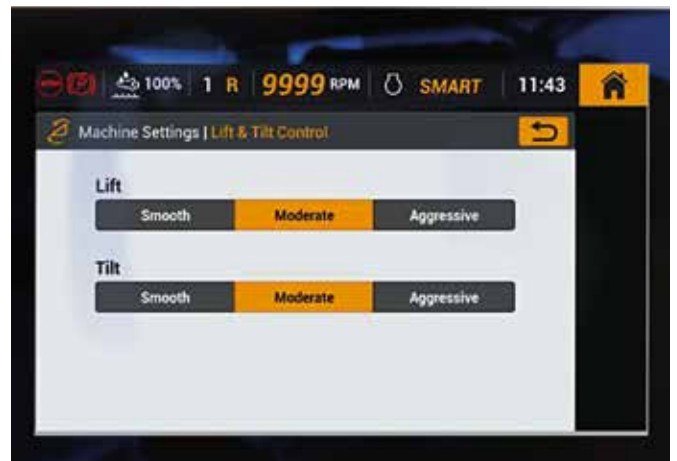

### TAILORED HYDRAULIC RESPONSE

Accessed via the touchscreen display, the hydraulic responsiveness of the lift and crowd functions, auxiliary hydraulics and joystick steering can be tailored to the application or operators experience.

- **Smooth:** more control for precision applications or novice operators
- **Moderate:** normal level of responsiveness
- **Aggressive:** sharper and more responsive control for fast operation and experienced drivers



# SPEND TIME SAVING MONEY.

A key benefit of the new Stage V compliant D series loaders is the vastly extended service intervals. At New Holland we know a vital machine such as a wheel loader has to be kept in top condition as it is often subject to a busy year round workload and can accumulate a high number of hours in a short period of time. In response to this we have doubled the engine service intervals from 500 to 1000 hours, and similarly increased the service intervals of other fluids and filters.

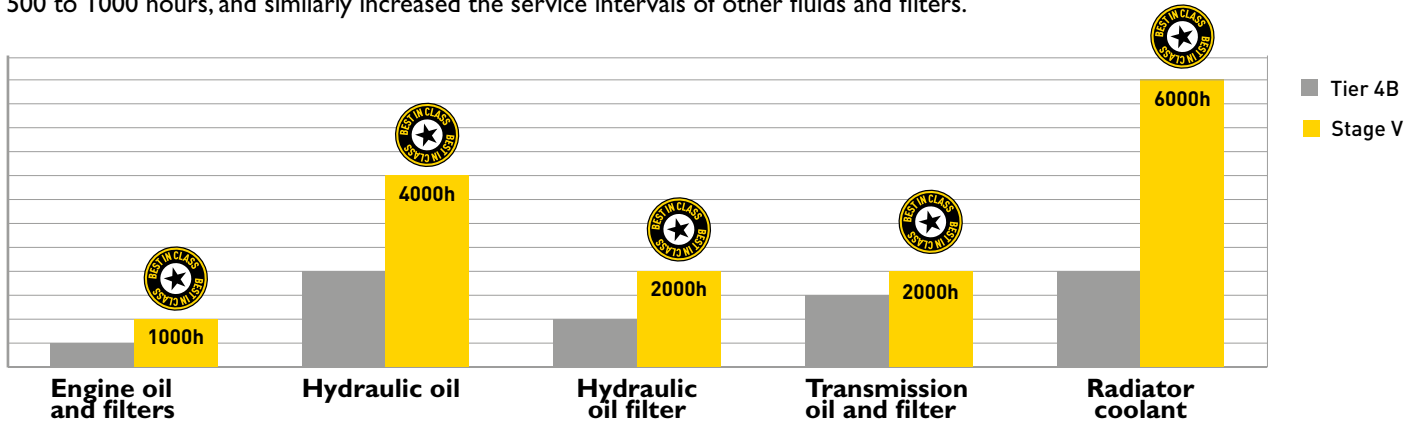

The figures speak for themselves, the time saved by not having to stop and service allows you to get to get the job done uninterrupted, what's more, you can save up to 20% on maintenance costs, a significant saving over the whole life of the machine. When combined with the fuel saving benefits of the new Smart engine work mode, New Holland D series wheel loaders guarantee low Total Cost of Ownership and keep you working for longer.

## Easy and fast service and maintenance

all key service items can be reached from ground level, the one-piece engine hood lifting and closing electronically for simplified access. The cube cooling pack is designed to be easy to clean. The cab filter can be removed, cleaned and replaced with no need to climb steps or fiddle with difficult fasteners. A further boost is the optional centralised greasing system.

New Holland D series wheel loaders are engineered for performance, longevity and reduced whole life operating costs.



- One piece engine hood features electric opening on W130 D, W150 D, W170 D and W190 D models



- Hood raise switch, battery kill switch and remote battery terminals are grouped at the rear



- Easy access to each of the individual radiators allows easy routine cleaning



- Ground level service access makes jobs simpler, faster and safer



- For security, the fuel tank and AdBlue tank are accessed only by raising the engine hood



# PRODUCTIVITY ENHANCING OPTIONS.



## TYRES

- New Holland offers a wide choice of factory fit tyres for work over paved surfaces or for use over soft ground or working on steep on steep slopes
- Wheel fender widths are available to match the selected wheel and tyre package



## QUICK COUPLER

- Attachment versatility and timeliness is guaranteed thanks to the heavy duty hydraulic quick coupler which is compatible with a wide variety of attachments
- Visible indicators show the operator the status of the locking pins

## JOYSTICK STEERING JSS

- The JSS system employs a joystick on the left armrest to control the steering function of the wheel loader
- Operator fatigue is greatly reduced and machine productivity is increased in repetitive-cycle operations such as truck loading and compost recycling, which typically follow a repetitive V pattern

## LED lighting

- Enhance safety and turn night into day with up to ten high intensity LED cab work lights
- Two additional LED hood lights illuminate the rear camera view to bring total light output to 43,000 lumens
- New egress lighting illuminates your path once the machine is switched off



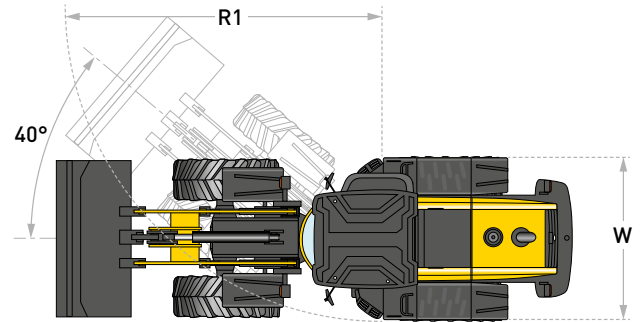
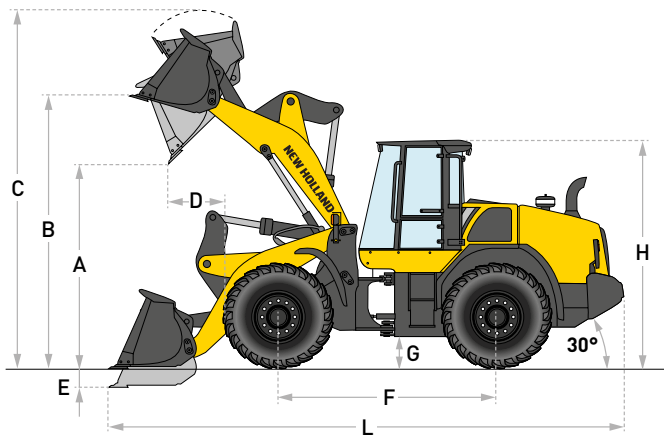

**DIMENSIONS** **W110D**

		Z-bar		Long Reach		Tool Carrier
		Direct	QC	Direct	QC	B.O.E.
Std GP Bucket Rated Capacity	(m <sup>3</sup> )	2.1	1.8	1.9	1.8	1.8
Bucket Capacity at 110% Fill Factor	(m <sup>3</sup> )	2.3	2	2.1	2	2
Bucket overall width	(mm)	2497	2497	2497	2497	2497
Bucket weight	(kg)	847	1052	813	1052	1050
A - Dump height at 45° @ full boom height	(mm)	2612	2482	3040	2922	2428
B - Bucket hinge pin height	(mm)	3605	3605	3985	2985	3743
C - Overall height	(mm)	4743	4740	5061	5120	4932
D - Bucket reach at full boom height	(mm)	1114	1069	1044	1127	1116
E - Digging depth	(mm)	83	102	108	137	197
F - Wheelbase	(mm)	2750	2750	2750	2750	2750
G - Ground clearance	(mm)	341	341	341	341	341
H - Cab roof height	(mm)	3275	3275	3275	3275	3275
L - Overall length on ground (with bucket)	(mm)	6838	6930	7111	7272	7120
Overall length on ground (w/o bucket)	(mm)	5770	5770	6090	6090	5730
W - Overall vehicle width (without bucket)	(mm)	2448	2448	2448	2448	2448
Departure angle	(°)	30	30	30	30	30
R1 - Turning radius (at outer wheel)	(mm)	5002	5002	5002	5002	5002
Turning radius (at bucket corner)	(mm)	5524	5523	5667	5688	5527
Full steering angle	(°)	40	40	40	40	40
Bucket rollback @ boom carry position	(°)	44	50	46	51	53
Bucket dump @ maximum boom height	(°)	55	45	51	40	57
Machine operating weight (L3 tyres)	(kg)	11098	11303	11192	11431	11564

**LOADER PERFORMANCE**

		Z-bar		Long Reach		Tool Carrier
		Direct	QC	Direct	QC	B.O.E.
Bucket payload	(kg)	3837	3677	3301	3123	3118
Maximum material density	(t/m <sup>3</sup> )	1.85	2.10	1.76	1.76	1.78
Tipping load straight	(kg)	8758	8418	7560	7184	7161
Tipping load full turn	(kg)	7673	7354	6601	6246	6235
Bucket break-out force	(daN)	7455	7155	7976	6883	7899
Loader speed						
Lift (full load)	(sec)	5.4	5.4	5.4	5.4	5.4
Dump (full load)	(sec)	1.2	1.2	2.4	2.4	2.4
Lowering (empty power down)	(sec)	3.9	3.9	3.9	3.9	3.9
Lowering (empty float down)	(sec)	3.9	3.9	3.9	3.9	3.9

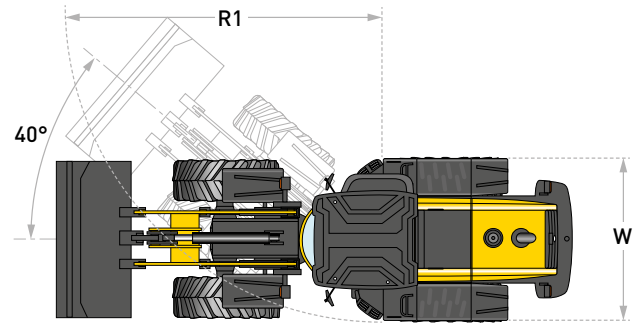
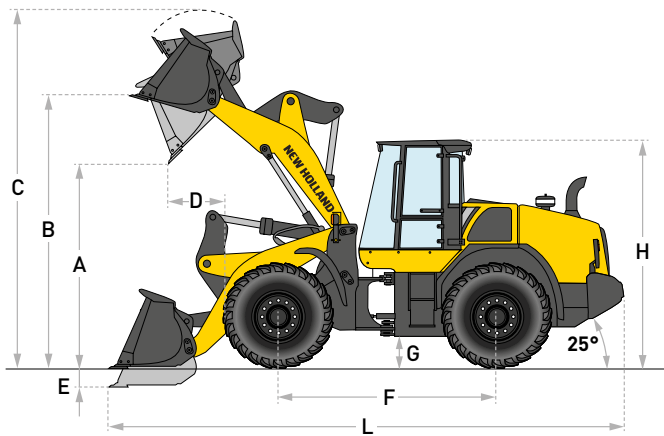

DIMENSIONS		W130D				
		Z-bar		Long Reach		Tool Carrier
		Direct	QC	Direct	QC	B.O.E.
Bucket mount (with bolt-on cutting edge)						
Std GP Bucket Rated Capacity	(m <sup>3</sup> )	2.3	2	2.3	2	2
Bucket Capacity at 110% Fill Factor	(m <sup>3</sup> )	2.5	2.2	2.5	2.2	2.2
Bucket overall width	(mm)	2497	2497	2497	2497	2497
Bucket weight	(kg)	924	1377	924	1377	1256
A - Dump height at 45° @ full boom height	(mm)	2745	2697	3273	3216	2572
B - Bucket hinge pin height	(mm)	3833	3832	4258	4256	3960
C - Overall height	(mm)	5044	5051	5469	5476	5233
D - Bucket reach at full boom height	(mm)	1073	1104	1074	1213	1105
E - Digging depth	(mm)	86	87	90	92	180
F - Wheelbase	(mm)	2900	2900	2900	2900	2900
G - Ground clearance	(mm)	389	389	389	389	389
H - Cab roof height	(mm)	3384	3384	3384	3384	3384
L - Overall length on ground (with bucket)	(mm)	7469	7524	7877	7935	7777
Overall length on ground (w/o bucket)	(mm)	6280	6280	6690	6690	6200
W - Overall vehicle width (without bucket)	(mm)	2478	2478	2478	2478	2478
Departure angle	(°)	25	25	25	25	25
R1 - Turning radius (at outer wheel)	(mm)	5223	5223	5223	5223	5223
Turning radius (at bucket corner)	(mm)	5758	5744	5961	5940	5725
Full steering angle	(°)	40	40	40	40	40
Bucket rollback @ boom carry position	(°)	45	50	46	51	59
Bucket dump @ maximum boom height	(°)	51	41	46	35	50
Machine operating weight (L3 tyres)	(kg)	12878	13330	13059	13512	13376

LOADER PERFORMANCE		W130D				
		Z-bar		Long Reach		Tool Carrier
		Direct	QC	Direct	QC	B.O.E.
Bucket mount (with bolt-on cutting edge)						
Bucket payload	(kg)	4724	4369	3960	3624	3806
Maximum material density	(t/m <sup>3</sup> )	2.01	2.15	1.7	1.8	1.88
Tipping load straight	(kg)	10662	10134	8957	8464	8826
Tipping load full turn	(kg)	9248	8737	7729	7249	7613
Bucket break-out force	(daN)	9907	9268	11672	9295	10242
Loader speed						
Lift (full load)	(sec)	6.3	6.3	6.3	6.3	6.5
Dump (full load)	(sec)	1.2	1.2	1.2	1.2	2.4
Lowering (empty power down)	(sec)	4.4	4.4	4.4	4.4	3.9
Lowering (empty float down)	(sec)	4.8	4.8	4.8	4.8	4.8

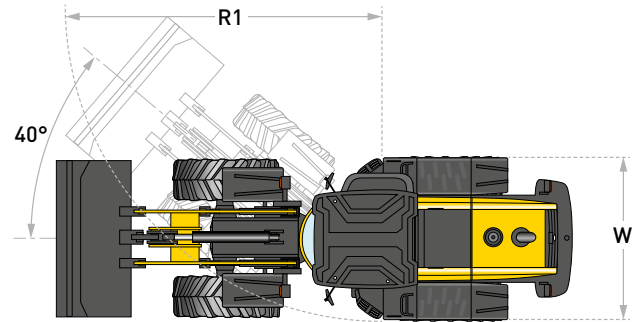
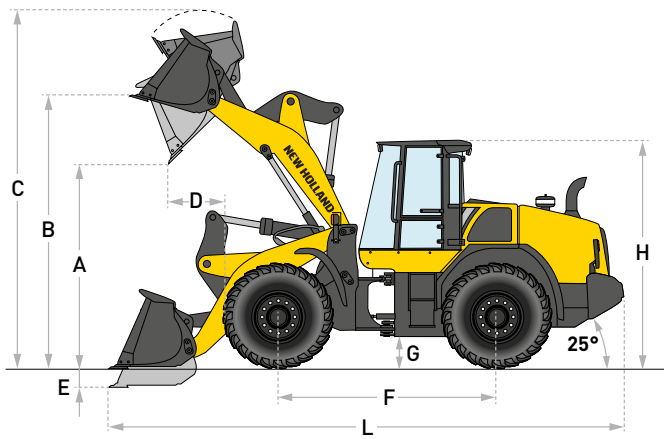

<b>DIMENSIONS</b>		<b>W150D</b>				
		Z-bar		Long Reach		Tool Carrier
		Direct	QC	Direct	QC	B.O.E.
Bucket mount (with bolt-on cutting edge)						
Std GP Bucket Rated Capacity	(m <sup>3</sup> )	2.3	2	2.3	2	2
Bucket Capacity at 110% Fill Factor	(m <sup>3</sup> )	2.5	2.2	2.5	2.2	2.2
Bucket overall width	(mm)	2497	2497	2497	2497	2497
Bucket weight	(kg)	924	1377	924	1377	1256
A - Dump height at 45° @ full boom height	(mm)	2850	2860	3331	3386	2569
B - Bucket hinge pin height	(mm)	3938	3936	4363	4361	3956
C - Overall height	(mm)	5149	5156	5574	5580	5230
D - Bucket reach at full boom height	(mm)	953	1053	993	1128	1105
E - Digging depth	(mm)	62	64	61	62	183
F - Wheelbase	(mm)	2900	2900	2900	2900	2900
G - Ground clearance	(mm)	389	389	389	389	389
H - Cab roof height	(mm)	3384	3384	3384	3384	3384
L - Overall length on ground (with bucket)	(mm)	7472	7530	7880	7938	7780
Overall length on ground (w/o bucket)	(mm)	6280	6280	6690	6690	6200
W - Overall vehicle width (without bucket)	(mm)	2478	2478	2478	2478	2478
Departure angle	(°)	25	25	25	25	25
RI - Turning radius (at outer wheel)	(mm)	5223	5223	5223	5223	5223
Turning radius (at bucket corner)	(mm)	5758	5744	5961	5940	5725
Full steering angle	(°)	40	40	40	40	40
Bucket rollback @ boom carry position	(°)	45	50	45	51	59
Bucket dump @ maximum boom height	(°)	47	37	41	31	50
Machine operating weight (L3 tyres)	(kg)	14062	14515	12980	14696	14446

<b>LOADER PERFORMANCE</b>		<b>W150D</b>				
		Z-bar		Long Reach		Tool Carrier
		Direct	QC	Direct	QC	B.O.E.
Bucket mount (with bolt-on cutting edge)						
Bucket payload	(kg)	5170	4908	4340	4095	4234
Maximum material density	(t/m <sup>3</sup> )	2.25	2.4	1.89	1.8	2.1
Tipping load straight	(kg)	11943	11400	10171	9568	9740
Tipping load full turn	(kg)	10340	9816	8680	8189	8467
Bucket break-out force	(daN)	9909	9265	10188	9290	10242
Loader speed						
Lift (full load)	(sec)	5.5	5.5	5.5	5.5	6.5
Dump (full load)	(sec)	1.1	1.1	1.1	1.1	2.4
Lowering (empty power down)	(sec)	4.4	4.4	4.4	4.4	3.9
Lowering (empty float down)	(sec)	4.3	4.3	4.3	4.3	4.2



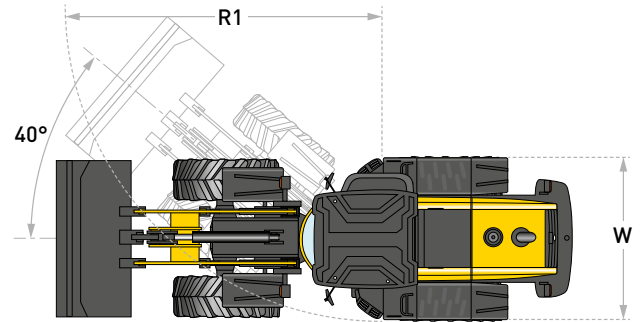
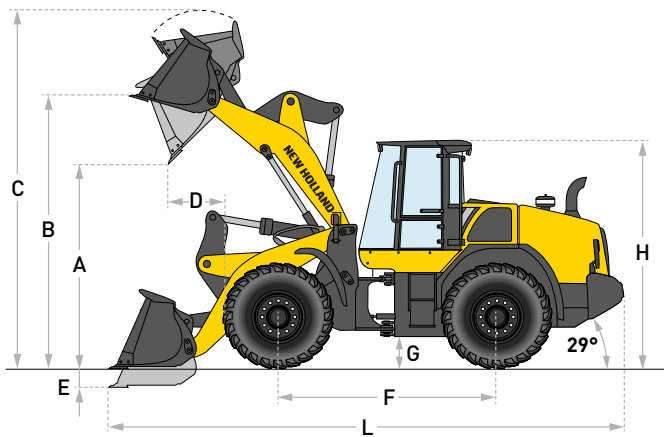

<b>DIMENSIONS</b>		<b>W170D</b>				
		Z-bar		Long Reach		Tool Carrier
		Direct	QC	Direct	QC	B.O.E.
Bucket mount (with bolt-on cutting edge)		Direct	QC	Direct	QC	B.O.E.
Std GP Bucket Rated Capacity	(m <sup>3</sup> )	2.7	2.7	2.7	2.5	2.7
Bucket Capacity at 110% Fill Factor	(m <sup>3</sup> )	3	3	3	2.7	3
Bucket overall width	(mm)	2712	2712	2712	2494	2712
Bucket weight	(kg)	1221	1745	1221	1155	1682
A - Dump height at 45° @ full boom height	(mm)	3031	2839	3429	3429	2796
B - Bucket hinge pin height	(mm)	4079	4078	4477	4477	4154
C - Overall height	(mm)	5429	5452	5827	5827	5504
D - Bucket reach at full boom height	(mm)	1015	1062	990	990	1162
E - Digging depth	(mm)	52	41	48	48	123
F - Wheelbase	(mm)	3253	3253	3253	3253	3550
G - Ground clearance	(mm)	384	384	384	384	437
H - Cab roof height	(mm)	3378	3378	3378	3378	3577
L - Overall length on ground (with bucket)	(mm)	7661	7841	8019	8019	7998
Overall length on ground (w/o bucket)	(mm)	6530	6530	6850	6850	5750
W - Overall vehicle width (without bucket)	(mm)	2558	2558	2558	2558	2978
Departure angle	(°)	29	29	29	29	29
RI - Turning radius (at outer wheel)	(mm)	5748	5748	5748	5748	5748
Turning radius (at bucket corner)	(mm)	6324	6405	6495	6398	6396
Full steering angle	(°)	40	40	40	40	40
Bucket rollback @ boom carry position	(°)	44	38	43	43	47
Bucket dump @ maximum boom height	(°)	47	48	47	47	61
Machine operating weight (L3 tyres)	(kg)	15642	16166	15845	15779	15911

<b>LOADER PERFORMANCE</b>		<b>W170D</b>				
		Z-bar		Long Reach		Tool Carrier
		Direct	QC	Direct	QC	B.O.E.
Bucket mount (with bolt-on cutting edge)		Direct	QC	Direct	QC	B.O.E.
Bucket payload	(kg)	5734	4994	4825	4860	4340
Maximum material density	(t/m <sup>3</sup> )	2.01	1.85	1.77	1.9	1.6
Tipping load straight	(kg)	13686	12003	11542	11612	10446
Tipping load full turn	(kg)	11467	9988	9651	9721	8679
Bucket break-out force	(daN)	14321	11889	14277	14315	11718
Loader speed						
Lift (full load)	(sec)	5.2	5.2	5.2	5.2	5.2
Dump (full load)	(sec)	1.2	1.2	1.2	1.2	1.3
Lowering (empty power down)	(sec)	2.5	2.5	2.5	2.5	2.5
Lowering (empty float down)	(sec)	2.4	2.4	2.4	2.4	2.4

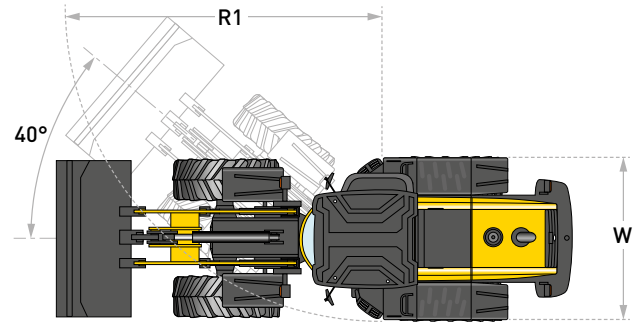
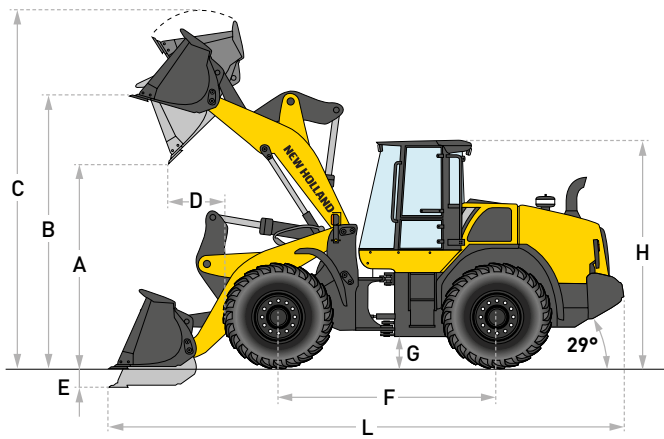

DIMENSIONS		W190D			
		Z-bar		Long Reach	
Bucket mount (with bolt-on cutting edge)		Direct	QC	Direct	QC
Std GP Bucket Rated Capacity	(m <sup>3</sup> )	3.4	3.2	3.2	3.2
Bucket Capacity at 110% Fill Factor	(m <sup>3</sup> )	3.7	3.5	3.5	3.5
Bucket overall width	(mm)	2946	2983	2946	2946
Bucket weight	(kg)	1568	2638	1539	2638
A - Dump height at 45° @ full boom height	(mm)	2932	2727	3394	3172
B - Bucket hinge pin height	(mm)	4120	4116	4561	4558
C - Overall height	(mm)	5483	5990	5890	6031
D - Bucket reach at full boom height	(mm)	1166	1184	1253	1303
E - Digging depth	(mm)	74	77	141	144
F - Wheelbase	(mm)	3340	3340	3340	3340
G - Ground clearance	(mm)	390	390	390	390
H - Cab roof height	(mm)	3380	3380	3380	3380
L - Overall length on ground (with bucket)	(mm)	8082	8261	8535	8746
Overall length on ground (w/o bucket)	(mm)	6780	6780	7240	7240
W - Overall vehicle width (without bucket)	(mm)	2480	2480	2480	2480
Departure angle	(°)	29	29	29	29
RI - Turning radius (at outer wheel)	(mm)	6030	6030	6030	6030
Turning radius (at bucket corner)	(mm)	6629	6685	6868	6945
Full steering angle	(°)	40	40	40	40
Bucket rollback @ boom carry position	(°)	45	44	43	43
Bucket dump @ maximum boom height	(°)	55	51	49	45
Machine operating weight (L3 tyres)	(kg)	18329	19397	18556	19665

LOADER PERFORMANCE					
		Z-bar		Long Reach	
Bucket mount (with bolt-on cutting edge)		Direct	QC	Direct	QC
Bucket payload	(kg)	6236	5443	4997	4281
Maximum material density	(t/m <sup>3</sup> )	1.87	1.7	1.58	1.4
Tipping load straight	(kg)	14880	13162	11941	10420
Tipping load full turn	(kg)	12472	10886	9944	8561
Bucket break-out force	(daN)	14752	12563	15395	12797
Loader speed					
Lift (full load)	(sec)	6.2	6.2	6.2	6.2
Dump (full load)	(sec)	1.2	1.2	1.2	1.2
Lowering (empty power down)	(sec)	2.9	2.9	2.9	2.9
Lowering (empty float down)	(sec)	2.5	2.5	2.5	2.5

		W110 D	W130 D	W150 D	W170 D	W190 D
<b>SPECIFICATIONS</b>						
<b>ENGINE</b>						
FPT Industrial engine		NEF N45	NEF N67	NEF N67	NEF N67	NEF N67
Displacement	(l)	4.5	6.7	6.7	6.7	6.7
Cylinders		4	6	6	6	6
Aspiration		Turbocharger with air-to-air cooling				
No EGR valve is used		Only fresh air is taken for combustion and no extra cooling system is needed				
Injection		Common Rail Multiple Injection				
After Treatment System		HI-eSCR 2 (DOC + SCRoF)				
Emissions level		Compliant with EU Stage V				
Max power	[kW/hp(CV)]	106/142 @ 1800rpm	128/172 @ 1800rpm	128/172 @ 1800rpm	145/195 @ 2000rpm	172/230 @ 1800rpm
Max torque	(Nm)	608 @ 1600rpm	730 @ 1600rpm	730 @ 1600rpm	950 @ 1300rpm	1184 @ 1300rpm
<b>TRANSMISSION</b>						
Gearbox		PowerShift™ 4 speeds	PowerShift™ 5 speeds "Ecoshift"*			
Clutch		Torque converter	Torque converter with: - Automatic lock-up engagement from 2nd up to 5th gear - Power inch: proportional declutching depending on braking intensity			
Forward	(km/h)	6-11-22-36	7-13-20-31-45	7-13-20-31-45	7-13-19-30-40	6.6-11-17-26-40
Reverse	(km/h)	6.4-12-23	7-14-32	7-14-32	8-14-31	7-12-28
<b>AXLES AND DIFFERENTIAL</b>						
Rear axle total oscillation	(°)	24				
Heavy duty ZF axles		–	100% locking front diff with open rear	Choice of: LSD front & rear, 100% locking front diff with open rear, 100% locking front with rear LSD		
Standard ZF axles		Limited slip differentials front and rear 73% tractive effort on slippery ground	–	–	–	–
<b>TYRES</b>						
Standard tyre size		17.5R25	20.5R25	20.5R25	20.5R25	23.5R25
<b>BRAKES</b>						
Service brake		Maintenance free, self-adjusting wet 4-wheel disc brakes				
Brake disc area	(m <sup>2</sup> /hub)	0.39	0.39	0.39	0.39	0.39
Parking brake		With the negative brake all four wheels are automatically stopped when the engine is stopped				
Parking disc brake area	(cm <sup>2</sup> )	58	58	58	82	82
<b>HYDRAULICS</b>						
Valves		Rexroth Closed-centre, Load sensing hydraulic system Main valve with 3 sections				
Steering		The steering orbitrol hydraulically is actuated with priority valve				
Automatic functions		Bucket Return-to-dig, Boom Return-to-travel, Boom Auto-lift, Parallel lift				
Control type		Pilot with proportional solenoid valves controlled by electro-hydraulic single joystick or single-axis 3 levers				
Type of pump	(l/min)	Single variable displacement pump			Tandem variable displacement pump	
		134 @ 2000rpm	169 @ 2000rpm	169 @ 2000rpm	206 @ 2000rpm	236 @ 2000rpm
<b>AUXILIARY HYDRAULIC CIRCUIT</b>						
Max flow	(l/min)	134	169	190	206	236
Max pressure	(bar)	249-255	249-255	249-255	249-255	249-255
<b>SERVICE CAPACITIES</b>						
Fuel tank	(l)	189	248	248	246	288
AdBlue tank, permanently heated by engine coolant	(l)	41.3	41.3	41.3	41.3	41.3
Cooling system	(l)	22	27	27	28	30
Engine oil	(l)	12	13	13	13	13
Hydraulic oil tank	(l)	57	91	91	91	91
Total hydraulic system oil	(l)	114	148	148	180	180
Front and Rear Axles	(l)	22 + 22	22 + 22	22 + 22	35 + 35	40 + 40
Transmission oil	(l)	19	27	27	34	34
<b>CAB PROTECTION</b>						
Protection against falling objects (FOPS)		ISO EN3449				
Protection against roll over (ROPS)		ISO EN13510				
<b>NOISE AND VIBRATION</b>						
In the cab - LpA (ISO 6595/6396/3744)	[dB(A)]	68	68	68	68	68
Outside - LwA (SAE J88 SEP80)	[dB(A)]	102	104	104	103	104
Vibrations		Operator's seat meets the criteria of ISO 7096:2000 The vibrations transmitted do not exceed 0.5m/s <sup>2</sup>				
<b>ELECTRICAL SYSTEM</b>						
System voltage	(V)	24	24	24	24	24
Batteries		2 x 12V	2 x 12V	2 x 12V	2 x 12V	2 x 12V
Alternator - capacity	(Amps)	70	120	120	120	120

– Not available

\* PowerShift™ 4 speeds is an option





The New Holland dealer network is, in itself, the best guarantee of continued productivity for the machines it delivers to its customers. New Holland service technicians are fully equipped to resolve all maintenance and repair issues, with each and every service point providing the high standards they are obliged to observe under New Holland's stringent quality guidelines. The New Holland global parts network ensures fast, reliable, replacement parts for less downtime, increased productivity and, of course, profitable operation for its customers.

**Learn more at [www.newholland.com](http://www.newholland.com)**

Printed on recycled paper  
CoC-FSC 000010 CQ Mixed sources



#### AT YOUR OWN DEALERSHIP

The information contained in this brochure is intended to be of general nature only. The NEW HOLLAND CONSTRUCTION MACHINERY S.p.A. company may at any time and from time to time, for technical or other necessary reasons, modify any of the details or specifications of the product described in this brochure. Illustrations do not necessarily show products in standard conditions. The dimensions, weights and capacities shown herein, as well as any conversion data used, are approximate only and are subject to variations within normal manufacturing techniques.