

W110c

TIER 2



W110C

STANDARD BUCKET PAYLOAD	3.5 ton
BUCKET VOLUME	1.9 - 4 m ³
PRODUCTIVITY (50 m DISTANCE)	180 t/h
OPERATING WEIGHT	11 ton
MAX GROSS POWER	142 hp



BUILT AROUND YOU

SPECIFICATIONS

PRODUCTIVITY

(50-METER DISTANCE CYCLE)

Considering: density: 1,8 t/m³, fill factor: 100%, 52 cycles/hour and each hour includes a 5-minute break..... 110 m³/h or 180 t/h of material
52 loading cycles/h with standard bucket 2.1 m³ or 3.48 ton

ENGINE

Compliant with EPA Tier2 or EU Stage II regulations.

FPT engine F4HFE314A

4 cylinders - 4,7 litres - common rail

Max power SAE J1995 106 kW / 142hp @1800 rpm

Maximum torque SAE J1995 608 Nm @1600 rpm

TRANSMISSION

All-wheel drive with planetary axles

kick-down function

4-speed torque converter

4-speed auto Powershift ZF type 4WG130, switchable to manual shifting

ZF , switchable to manual shifting

forward speeds 6-11-22-36 Km/h

reverse speeds 6.4-12-23 Km/h

Adjustable transmission declutch

AXLES AND DIFFERENTIAL

For outstanding traction with 50% longer maintenance intervals and 30% less tire wear

100% auto-lock differential on front axle and open rear axles

Front and rear ZF Heavy Duty axles (options) with Open

Differential

type MT-L3065-II

Excellent traction

29% Limited slip differential on front and rear axles

front and rear axle ZF type MT-L3065-II

TYRES

Tyres 17,5R25

BRAKES

Service brake Maintenance free, self-adjusting wet 4-wheel disc brakes

Area 0,31 m²/hub

Parking brake Disc brake on transmission activated from the cab cluster

Area 58 cm²

HYDRAULICS

Valves Rexroth Closed-center, Load sensing hydraulic system.

Main valve with 3 sections

Steering The steering orbitrol hydraulically is actuated with priority valve

Type of pump Variable displacement pump (134 l/min @250 bar)

Automatic hydraulic functions

- Bucket Return-to-dig

- Boom Return-to-travel

- Auto.lift (to adjustable height)

Control type Pilot control with single joystick or two levers

CAPACITIES

Fuel tank 189 usable litres

Cooling system 22 litres

Engine oil 12 litres

Hydraulic oil Tank: 57 litres, total system: 114 litres

Transmission oil 19 litres

CAB AND CONTROLS

For you safety the cab complies to:

protection against falling objects (FOPS) ISO EN3449

protection against roll over (ROPS) ISO EN13510

NOISE AND VIBRATION

Interior noise 72 dB(A) according to ISO6595/6396/3744

Exterior noise 72 dB(A) at 15 meters as per SAE J88 SEP80

105 dB(A) according to ISO6395/6396/3744

Switchable reverse gear alarm

Vibrations air-cushioned seat

ELECTRICAL SYSTEM

24V. Batteries 2 x 12V.

Alternator 70A

PERFORMANCE DATA

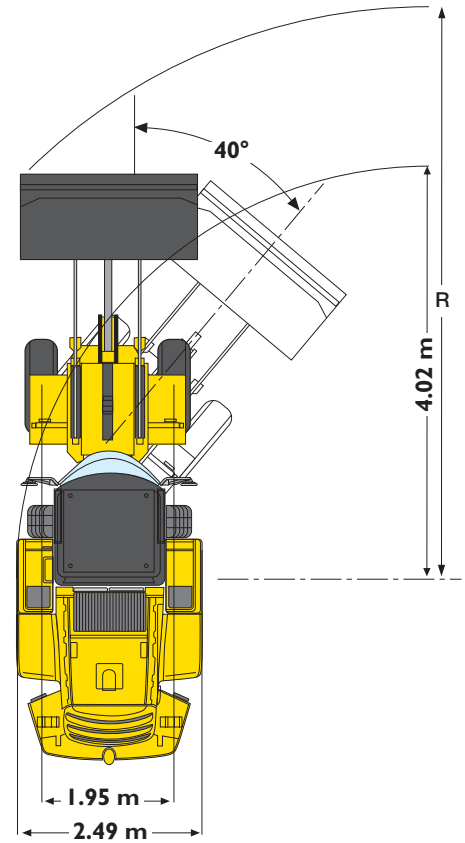
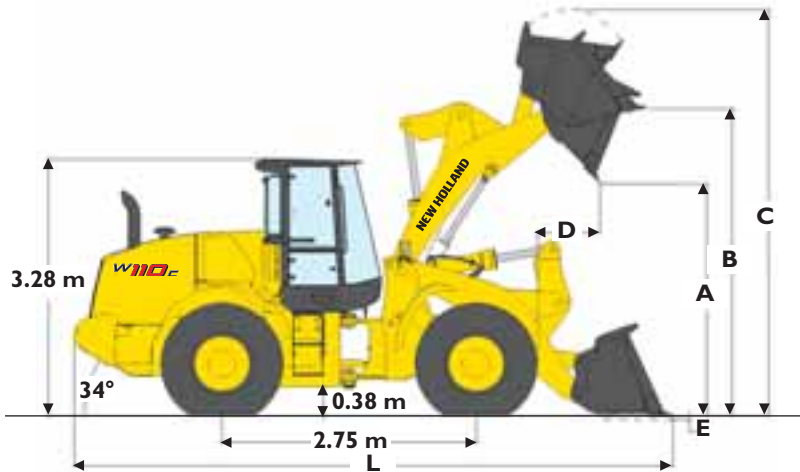

W110C	Bucket with bolt on:	Z-BAR buckets				LONG REACH buckets				TC buckets	
		1.9 m ³		1.7 m ³ w/QC		1.9 m ³ bucket		1.7 m ³ w/QC		1.7 m ³ w/QC	
		edge	teeth	edge	teeth	edge	teeth	edge	teeth	edge	teeth
Bucket volume (heaped)	m ³	2.07	1.98	1.70	1.70	1.88	1.84	1.70	1.70	1.70	1.70
Bucket Payload	kg	3478	3475	3535	3584	2977	2975	2947	2994	3249	3296
Maximum material density	ton/m ³	1.8	1.7	2.1	2.1	1.6	1.6	1.7	1.8	1.9	1.9
Bucket outside width	m	2.49	2.54	2.44	2.44	2.49	2.54	2.44	2.44	2.44	2.44
Bucket weight	kg	857	857	1137	1065	821	842	1137	1065	1117	1045
Tipping load - straight	kg	8150	8145	8317	8415	7011	7010	6985	7080	7634	7728
Tipping load - Articulated at 40°	kg	7264	6949	7069	7167	5955	5950	5894	5989	6497	6591
Breakout force	kg	7591	7781	7104	6959	8094	8366	7077	6933	8288	8124
Lift capacity from ground	kg	8889	8979	10620	10700	8830	8827	8689	8773	10236	10365
A - Dump height at 45° at full height	m	2.62	2.55	2.58	2.56	3.04	2.97	2.96	2.94	2.5	2.49
B - Hinge pin height	m	3.61	3.61	3.61	3.61	3.99	3.99	3.99	3.99	3.75	3.75
C - Overall height	m	4.75	4.75	4.77	4.77	5.06	5.06	5.14	5.14	4.94	4.94
D - Bucket reach at full height	m	1.12	1.19	1.18	1.22	1.05	1.12	1.16	1.19	1.23	1.27
E - Dig depth	cm	8	8	7	5	11	11	10	9	19	18
L - Overall length with bucket on the ground	m	6.83	6.94	6.90	6.92	7.11	7.21	7.24	7.27	7.05	7.07
R - Turning radius to front corner of the bucket	m	5.5	5.6	5.5	5.5	5.7	5.7	5.6	5.7	5.5	5.6
Bucket rollback in carry position	°	43°	43°	48°	48°	44°	44°	50°	50°	52°	52°
Dump angle at full height	°	55°	55°	50°	50°	51°	51°	46°	46°	62°	62°
Machine operating weight	kg	10448	10468	10728	10656	10582	10602	10897	10825	11189	11117

Note: bucket specification can slightly differ according to plant source. More bucket choice is available, please contact your local dealer.

PARTS AND SERVICE

The New Holland dealer network is, in itself, the best guarantee of continued productivity for the machines it delivers to its customers. New Holland service technicians are fully equipped to resolve all maintenance and repair issues, with each and every service point providing the high standards they are obliged to observe under New Holland's stringent quality guidelines. The New Holland global parts network ensures fast, reliable, replacement parts for less downtime, increased productivity and, of course, profitable operation for its customers.



AT YOUR OWN DEALERSHIP

The information contained in this brochure is intended to be of general nature only. The NEW HOLLAND CONSTRUCTION MACHINERY S.p.A. company may at any time and from time to time, for technical or other necessary reasons, modify any of the details or specifications of the product described in this brochure. Illustrations do not necessarily show products in standard conditions. The dimensions, weights and capacities shown herein, as well as any conversion data used, are approximate only and are subject to variations within normal manufacturing techniques.

Printed in Italy - MediaCross Firenze - Cod IR2410NCGB - Printed 10/12

Printed on recycled paper
CoC-FSC 000010 CQ Mixed sources



ELEMENTAL
CHLORINE
FREE
GUARANTEED



BUILT AROUND YOU