

# LOADER BACKHOES

B75D | B95D | B95D TC | B110D







## New levels of comfort and productivity.

New D Series loader backhoes from New Holland represent a huge step forward in operator comfort and productivity while delivering Tier 4 Final emission compliance without compromise. A new cab design featuring 10% more space, new rear side windows, vastly improved clearance when turning the seat for backhoe operation, and hugely improved in-cab storage capacity guarantees an enhanced operator experience and increased operator productivity.

Many customers need a loader that offers the versatility to do a lot more than just move bulk material, including grading and leveling as well as grabbing heavy items like tree trunks and concrete pillars. They also need a tractor unit offering the traction and power to push materials into place or out of the way. With a 4-in-1 bucket, a D Series loader backhoe delivers exceptional performance with just a single attachment. Choose a 6-in-1 bucket and you have the option to flip down adjustable pallet forks for handling palletized loads without a dedicated vehicle. The backhoe can be equipped with a wide choice of buckets to match excavation, water-course clearance, trenching and other demands.

You can also fit post hole diggers, hydraulically extendable dipper and countless other tools. The long, nearly 23-ft. reach of both the standard and telescopic dipper allows digging depth comparable to many conventional dedicated excavators. Add the new updated cab featuring a new heated seat and up to ten LED lights and exterior side lights on the cab roof, and there are no performance compromises with a New Holland D Series loader backhoe.



Models	Engine power (hp)	Loader lift capacity Straight/Tool Carrier (lbs.)	Max. backhoe reach (ft. in.)	Hydraulic flow (gpm)
B75D	74	8157	22' 1"	32.5
B95D	97	7833	20' 4"	40
B95D TC	97	7606	20' 9"	40
B110D	110	7833	22' 11"	40

# Built-in versatility.

D Series loader backhoes are your versatile choice for loading, grading, grabbing, lifting, excavating, digging, planting, post hole boring and the list goes on. Businesses from agriculture to horticulture, landscaping to drainage and irrigation need versatile and cost-effective equipment. With a loader backhoe there are loader and backhoe specification choices. The four-wheel-drive B95D and B110D boast powerful drive performance along with an electric differential lock on the loader arm for enhanced traction. Entry-level B75D models are affordable yet come with a high standard specification to suit a wide range of needs. A D Series loader backhoe is one investment that will never be short of work.



Cab noise levels are reduced by 3 decibels to 74dB(A)

Wider cab frame increases visibility and leg room

Automatic engine protection system

Tier 4 Final, 3.4 Liter, four-cylinder F5 engine

ECO, auto-idle & auto-shutdown engine modes for increased economy

One-sided service access simplifies serviceability

Straight loader arm design (Tool Carrier version available)

Up to 10,957 lbs. lift capacity



Excellent all-round visibility

Up to 8 working lights

Heated seat

Spacious new cab with 10% increase in volume and added storage compartments

3,108 lbs. of backhoe crane capacity

Fixed or extendable backhoe dipper

Center pivot backhoe

Mechanical or pilot-hydraulic backhoe control

New F-N-R switch on the loader multifunction lever (only available on models with the PowerShift transmission)

Four-wheel-drive standard with selectable two-wheel-drive

New in-cab cooler

Mechanical powershuttle or automatic PowerShift™ transmission

# Your comfort is guaranteed.

The all-new, class-leading D Series cab gives you more—more space, storage, glass area, and comfort—not to mention a wide range of new features. The cab is now wider, so you can turn the seat easier when transitioning from front loader work to backhoe. New rear side windows allow better visibility and less obstruction. A redesign of the right-side console improves ergonomics and control layout, regardless of what direction you are working in.

Storage capacity has been significantly increased with the addition of two lockable compartments, two bottle holders, four open trays. Two USB ports to charge devices, Bluetooth radio and mobile phone holder increases operator convenience. In-cab noise levels have been reduced by 3 dB(A). A high-grip floor covering comes standard to help prevent the operator slipping when entering the cab with muddy footwear.

A powerful lighting package featuring up to ten optional LED lights provide a true 360-degree light pattern thanks to the roof-mounted side lights. Large retractable sun visors, cup holders, glove box and a deluxe pneumatic heated seat are included. And to top it off, the engine exhaust is located to the right side of the cab to provide a clear view of the loader arm.



- Ample in-cab storage
- New speedometer option on the steering wheel console



- More clearance and legroom when transitioning to operate the backhoe
- A choice of entry-level mechanical and deluxe heated pneumatic suspension seats is available
- Low 74dB(A) in-cab noise level
- High visibility is a key design priority—D Series loader backhoes deliver with extremely slim cab pillars, both front and rear



- A-pillar-mounted exhaust offers a clear view of the loader



- Primary controls are mounted on the side to allow operation from both forward and backhoe seat positions
- Uncluttered side console houses all necessary buttons
- Dashboard is easy to read with the seat in either its forward or reverse position
- Optional immobilizer system protects against theft and unauthorized use



- Single multifunction proportional control lever for all loader controls
- 4 in 1 or 6 in 1 bucket opening, diff lock and transmission de-clutch functions are also activated from the lever
- New F-N-R switch on the multifunction lever for easy direction changes



- Powerful heating and ventilation with standard air-conditioning ensures operator comfort throughout the day
- Repositioned ventilation switches are easily accessible regardless of working position
- New ventilated cooler keeps drinks cool



- Up to 8 work lights, including roof-mounted side lights, are available



- Backhoe joystick towers adjust in all directions for the most comfortable position
- New rear side windows and slim cab pillars allow better visibility when operating the backhoe



- Up and over rear window is light in weight and easy to open and close
- Two new USB ports
- Bluetooth radio and phone holder

# PowerShift™ or powershuttle, it's your choice.

D Series loader backhoes come with switchable two- or four-wheel-drive, a powershuttle forward/reverse mechanical transmission, or the automatic PowerShift™ transmission. All PowerShift models now feature a convenient F-N-R switch on the front loader multifunction lever.







### The right front axle for the job

- Heavy-duty front axles are standard on all D Series models
- A tight turning radius can be maintained in all conditions



### The right rear axle for the job

- The rear axles on all D Series models is fitted with a fully locking rear differential that's engaged via a button on the loader joystick



### Mechanical four-speed powershuttle

- Floor-mounted gear lever with steering column-mounted electro-hydraulic forward/reverse shuttle
- Four gears with transmission de-clutch button incorporated into the gear lever
- Affordable, dependable and easy to use
- Ideal choice in applications where the backhoe will get more use than front loader



### Automatic four-speed PowerShift™

- Steering column-mounted lever for shuttle and speed selection
- Fully modulated gear shifting with speed-matching F-N-R switch on the loader multifunction lever
- Easy to use and maintain
- Ideal transmission choice for extensive front loader work
- Loader joystick is fitted with a transmission de-clutch button to divert full power to hydraulics as required
- Selectable two- or four-wheel-drive

# The numbers say it all.

With a New Holland D Series loader backhoe, there is no compromise in performance. Depending on model, the front loader can be fitted with a 1.3 cu. yd. standard bucket, a 4x1 or 6x1 bucket to raise loads up to 8,157 lbs. The backhoe has a maximum digging depth of 15 ft., which increases to 19 ft. with the hydraulically extendable dipper. Bucket breakout as high as 13,418 lbf, with backhoe dipper cylinder tear out rated at 7,248 lbf to 5,368 if extended.

Models		B75D	B95D	B95D TC	B110D
Lift capacity at full height	lbs.	8157	7996	7606	7833
Hinge pin height	in.	140	133	133	133
Digging depth	ft. in.	18' 4"	18' 4"	18' 4"	18' 4"
Max. bucket tearout	ft./lbs	12,138	12,933	12,933	12,933
Max. reach	ft. in.	22' 0"	20' 7"	20' 9"	22' 10"



### TC Tool Carrier loader arm features

- Mechanical parallel lift and lower
- Ideal for pallet and loading work
- Optional hydraulic coupler



### Straight loader arm features

- Optional Glide Ride (B95D B110D Only)
  - automatically activates above/below 3 preset speeds
  - default speeds for activation/deactivation are 6/5 mph
  - improves material retention over uneven terrain
  - enables faster load cycle times
  - higher travel speeds reduce roading times
- Return-to-dig and float modes
- Choice of standard, 4-in-1 or 6-in-1 buckets



### Versatile bucket options

- Versatile 4-in-1 bucket is suitable for work such as dozing and grading, bulk-materials handling and for grabbing
- The 6-in-1 design adds adjustable forks for pallet work, lifting open loads and working with a strop



### Backhoe—standard features

- Curved arm design for easier loading over trailer sides and obstacles
- Center-pivot arm
- Long-life pivots with ground-level greasing points
- Wide pad stabilizers with adjustable footing
- Powerful bucket and dipper breakout for optimum performance
- Lift eye on B75D, B95D and B110D models

### Key backhoe specification choices

- Fixed or extendable dipper arm option
  - fixed dipper provides 15 ft. digging depth
  - telescopic dipper extends dig depth to 19 ft.
- Direct fit or quick coupler bucket choice



### Pilot controls (shown at left)

- With full proportional control, pilot backhoe control joysticks are fully adjustable
- Selectable ISO or SAE operating patterns
- New joystick rocker switch controls the dipper extension on HED
- Precision swing control for precise excavating and dumping

### Mechanical controls (not shown)

- Conventional mechanical controls for the backhoe provide good feedback and response from the hydraulics
- Stabilizer controls are now located next to the backhoe control levers for better ergonomics

# Hydraulic power to meet every demand.

To precisely match customer needs, D Series loader backhoes are offered with a choice of hydraulic pump designs. In addition, an auxiliary hydraulic circuit is available to power attachments such as hydraulic breakers and soil augers. Two hydraulic pump designs are available:

## **Twin gear pump (mechanical controls)**

- Simple
- Constant flow
- Fast warm up
- Straightforward service and maintenance
- For general use—ideal for applications with limited roading
- Maximum flow 39.8 gpm @ 2200 rpm
- Maximum operating pressure 2,973 psi

## **Variable displacement pump (pilot controls)**

- Only active when there is a demand for oil
- Flow rate proportional to demand
- Reduces fuel consumption
- Reduced oil temperature due to flow on demand
- Ideal for intensive backhoe operation and frequent roading
- Variable flow from 1.5 to 41.2 gpm
- Maximum operating pressure 2,973 psi





- A variable displacement hydraulic pump only delivers flow on demand, saving fuel when roading and in applications such as dozing and grading

- An optional auxiliary hydraulic circuit on B95D and B110D models delivers 0-35.9 gpm
- Ideally suited to working soil augers, large grabbers and hydraulic breakers



# Powerful. Clean. Efficient.

Developing 74 to 110 hp depending on model, the new FPT Industrial F5 3.4-liter, four-cylinder engine is the same unit proven in New Holland T5 tractors. Compliant with stringent Tier 4 Final emission regulations, the engines have an advanced throttle control system that allows the operator to adjust how the engine responds to throttle inputs from smooth to fast. New D Series models also feature three, new fuel-saving modes to increase economy and reduce wear and tear on the machine.

## Powered by FPT Industrial

New Holland is not going it alone when it comes to Tier 4 Final technology, they can draw on the experience of their in-house engine development specialist: FPT Industrial.

**Pioneers:** Common Rail technology developed by FPT Industrial at their R&D excellence center in Arbon, Switzerland in the 1980s and brought it to the masses in 1997 on the Alfa Romeo 156. They were the very first to introduce it on agricultural machines on the TS-A tractor. Pioneering. Always.

**Cleaner:** For the ninth consecutive year, CNH Industrial has topped the Dow Jones Sustainability World and Europe Indexes for the Industrial Engineering sector. Cleaner. Everywhere.

**Proven:** FPT Industrial has pioneered SCR technology since 1995 and has already produced over 1 million SCR engines during the last eight years for the agricultural, construction and haulage industries. Reliability. Confirmed.





- Output choice of 74, 97 or 110 hp
- Side-mounted exhaust stack improves visibility
- Engine shut-down protection in the event of low oil pressure or high coolant or transmission oil temperatures
- 34.6 gal. fuel and 3.4 gal AdBlue capacity
- Three throttle settings—soft, normal and fast. Operator can select the throttle setting best suited to the application



### Compact HI-eSCR after-treatment emission system

FPT Industrial developed a specific after-treatment dedicated to compact equipment. Compact High Efficiency SCR is designed for applications whose working cycle is characterized by low exhaust temperatures and frequent stopping and going. By combining proven Selective Catalytic Conversion with low-rate exhaust gas recirculation, an F5 engine can be operated at low loads. The efficient after-treatment system is totally maintenance-free—you'll experience no downtime for filter replacement or mechanical cleaning during the machine's life cycle.



### 3 new fuel saving features

- ECO mode: automatically regulates engine speed and hydraulic pressure depending on demand, enabling up to 10% fuel savings
- Auto-idle: can be set to activate after 5 sec. to up to 60 sec. of idle time
- Auto-shutdown: can be set to activate after up to 60 mins. of idle time



### Chassis

All backhoe models benefit from a full-frame chassis. All stress is diverted through the strong, robust frame with no load on the engine or transmission.

- Robot-welded full-length frame chassis
- No stress on engine or transmission
- Plate-reinforced stress points
- Cast backhoe slider interface
- Open design to facilitate maintenance

## Easy servicing all-around.

Routine care is the key to equipment performance and longevity. The D Series loader backhoe is designed for fast, easy routine service checks and features long 500-hour engine and 1,000-hour transmission service intervals to reduce downtime. Easy access is provided to all key fuel, engine, transmission and hydraulic filters, and all engine servicing can now be performed from one side for added convenience.



- One-piece flip-up hood offers full engine access

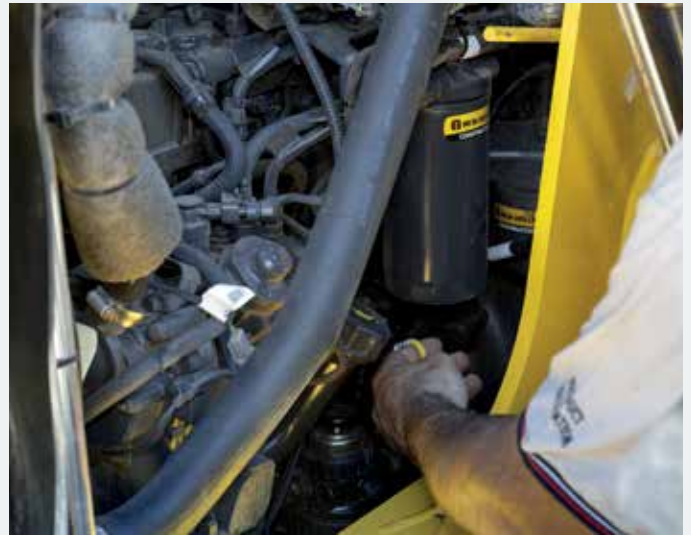

- All key daily checks are grouped together on one side







- Battery-disconnect and remote jump-start terminals are easily accessible



- Quickly and safely access all key lubrication points on the loader and backhoe from the ground



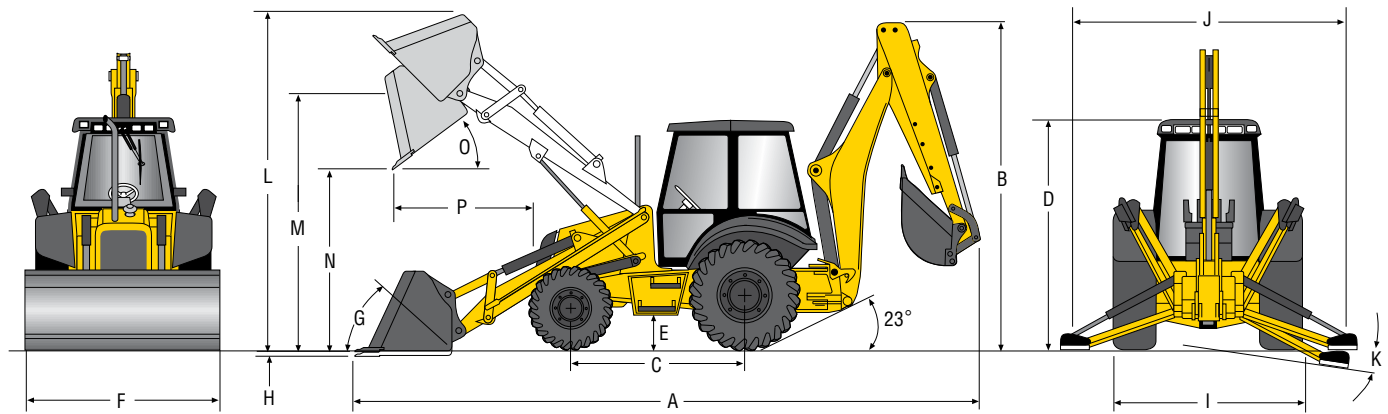

DIMENSIONS				
<b>A.</b>	Transport length, ft/in (mm)	23' 1" (7030)	<b>G.</b> Bucket Rollback At ground level	33°
<b>B.</b>	Transport height, ft/in (mm)	12' 7" (3840)	<b>H.</b> Digging depth below grade, in (mm)	4" (110)
<b>C.</b>	Wheelbase, in (mm) 4WD	86" (2175)	<b>I.</b> Transport width, ft/in (mm) Overall width, ft/in (mm) Reversible pads	7' 6" (2300)
<b>D.</b>	Height to top of cab, ft/in (mm)	9' 3" (2825)	<b>J.</b> Stabilizer spread, operating, ft/in (mm)	10' 7" (3226)
<b>E.</b>	Ground Clearance, in (mm)	19" (500)	<b>K.</b> Stabilizer spread, leveling angle	14°
<b>F.</b>	Blade width, ft/in (mm)	7' 5" (2277)		

LOADER DIMENSIONS		
		<b>1.1 cu yd Heavy-Duty General Purpose</b>
<b>M.</b>	Height to hinge pin, ft/in (mm)	11' 8" (3580)
<b>N.</b>	Dump height, ft/in (mm)	8' 11" (2732)
<b>O.</b>	Max dump angle	45°
<b>P.</b>	Reach @ 45 degree dump angle, ft/in (mm) Max grading angle	2' 7" (797) 116°

Unit equipped with 12-16.5 front tire, 19.5L-24 rear tire

LOADER PERFORMANCE		
		<b>1.1 cu yd Heavy-Duty General Purpose</b>
	Linkage geometry	straight
	Bucket breakout force, lbf (daN)	13,778 (6250)
	Lift capacity to full height, lbs (kg)	8157 (3700)
	SAE heaped capacity, cu yd (m <sup>3</sup> )	1.3 (1.0)
	Bucket weight, lbs (kg)	1014 (460)
	Cutting width, in (mm)	89 (2270)
	Cycle	
	Raise to full height	5.90 sec
	Dump time	1.80 sec
	Lower	3.20 sec

WEIGHT	
Base Unit (4WD, Cab)	17,487 lbs
With options added	
Canopy	-145 lbs
4x1	+1708 lbs
6x1	+2107 lbs

TRANSMISSION	
	<b>Power Shuttle</b>
Manufacturer	Carraro
Transmission type	Synchromesh
Gear	4F/4R
Max Fwd travel speed, mph (kph)	24.4 (39.3)

Note: Travel Speeds with 19.5L-24 Rear Tires

ENGINE	
Make and model	F5HFL463*A
Type	Tier 4 Final certified, Diesel Oxidation Catalyst HPCR, 4-cycle diesel
Aspiration	Turbocharged Aftercooled
Rated RPM	2200
Number of cylinders	4
Displacement, cu in (l)	207 (3.4)
Horsepower, gross, hp (kW)	74 (55)
Horsepower, net hp (kW)	68.4 (51)
Peak torque, lb-ft (Nm) @ RPM	233 (316) @ 1400

MANEUVERABILITY		
	<b>Less Brakes</b>	<b>With Split Brakes</b>
4WD curb clearance	15' 9"	11' 5"
4WD bucket clearance	19' 5"	16' 6"

\*4WD, CAB, HED, Heavy Duty Counterweight, STD Bucket

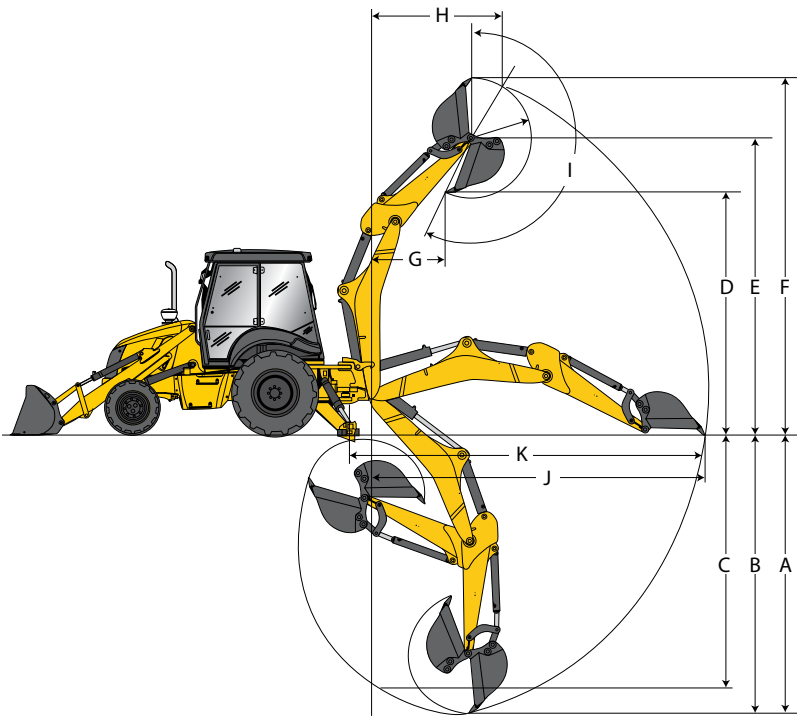

HYDRAULIC SYSTEM	
Mechanical Control Pump	Gear Pump
System type	Twin Gear
Main pump type	Dual gear
Pump capacity gpm (lpm)	32.5 (123)
System relief pressure	3045 psi

ELECTRICAL	
Alternator output	120 amps
Battery capacity	800 CCA

REFILL CAPACITIES	
Fuel tank, gal (l)	34 (129)
Cooling system, gal (l)	5.2 (20)
Engine oil, includes filter, gal (l)	2.1 (8.0)
Hydraulic tank, gal (l)	13.4 (50.7)
Hydraulic system, gal (l)	28 (107)

CYLINDER SPECS	
Loader cylinder	3.54" bore x 28.62" stroke
Backhoe	
Boom cylinder	5" bore x 35.71" stroke
Arm cylinder	4.75" bore x 27.64" stroke
Bucket cylinder	3.5" bore x 30.16" stroke
Swing cylinder	4.33" bore x 9.37" stroke

SERVICE INTERVALS	
Engine oil	500 hours
Hydraulic oil filter	1000 hours
Engine coolant	2000 hours
Rear axle oil	1000 hours

BACKHOE DIMENSIONS				
		Standard	Retracted	Extended
<b>A</b>	Max dig depth, ft/in (mm)	14' 5" [4399]	15' 11" [4547]	18' 4" [5584]
<b>B</b>	Dig depth, 2' level bottom, ft/in (mm)	14' 3" [4344]	14' 11" [4547]	18' 4" [5578]
<b>C</b>	Dig depth, 8' level bottom, ft/in (mm)	13' 1" [3988]	13' 9" [4191]	17' 5" [5298]
<b>D</b>	Loading Height, ft/in (mm)	11' 11" [3644]	11' 11" [3645]	14' 1" [4280]
<b>E</b>	Max pin height, ft/in (mm)	14' 10" [4512]	15' 2" [4610]	17' 3" [5245]
<b>F</b>	Max operating height, ft/in (mm)	18' 1" [5489]	18' 4" [5585]	20' 4" [6220]
<b>G</b>	Loading Reach @ max height, ft/in (mm)	6' 5" [1964]	6' 8" [2050]	9' 5" [2885]
<b>H</b>	Dig reach @ max height, ft/in (mm)	8' 5" [2556]	8' 10" [2701]	11' 7" [3535]
<b>I</b>	Bucket rotation (max)	204°	204°	204°
<b>J</b>	Reach from swing post, ft/in (mm)	18' 5" [5625]	18' 10" [5762]	22' 0" [6739]
<b>K</b>	Reach (overall), ft/in (mm)	18' 6" [5657]	19' 0" [5792]	22' 1" [6739]

BACKHOE PERFORMANCE			
	Standard	Retracted	Extended
Bucket capacity, cu ft (m <sup>3</sup> )	7.5 (.21)	7.5 (.21)	7.5 (.21)
Bucket digging force, lbs (kg)	12,138 (5696)	12,138 (5696)	12,138 (5696)
Boom lift @ -8 ft, lbs (kg)	3227 (1467)	2732 (1242)	2328 (1058)
Dipper lift @ +10 ft, lbs (kg)	4070 (1850)	3540 (1609)	2572 (1179)

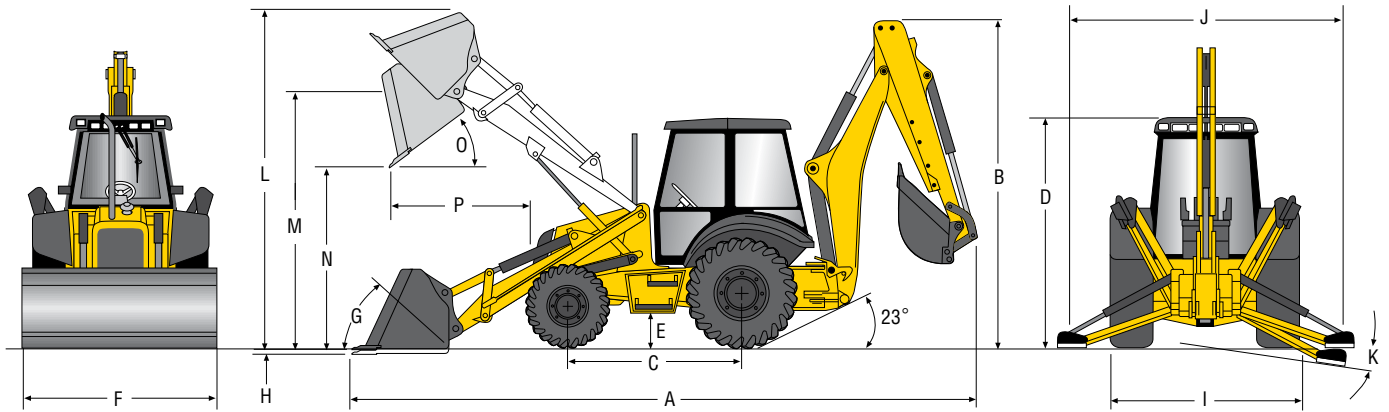

DIMENSIONS			
<b>A.</b>	Transport length, ft/in (mm)	23' 9" (7234)	
<b>B.</b>	Transport height, ft/in (mm)	12' 6" (3810)	
<b>C.</b>	Wheelbase, in (mm)		
	2WD	86 (2180)	
	4WD	86 (2180)	
<b>D.</b>	Height to top of cab, ft/in (mm)	9' 2" (2805)	
<b>E.</b>	Ground Clearance, in (mm)	12 (300)	
<b>F.</b>	Blade width, ft/in (mm)	7' 5" (2248)	
<b>G.</b>	Bucket Rollback		
	At ground level		43°
	Raised		55°
<b>H.</b>	Digging depth below grade, in (mm)		9" (234)
<b>I.</b>	Transport width, ft/in (mm)		7' 6" (2300)
	Overall width, ft/in (mm)		
	Ground pads		7' 7" (2318)
	Reversible pads		8' 2" (2484)
<b>J.</b>	Stabilizer spread, operating, ft/in (mm)		10' 7" (3226)
<b>K.</b>	Stabilizer spread, leveling angle		14°

LOADER DIMENSIONS		
		<b>1.1 cu yd Heavy-Duty General Purpose</b>
<b>L.</b>	Max operating height, ft/in (mm)	14' 5" (4400)
<b>M.</b>	Height to hinge pin, ft/in (mm)	11' 1" (3384)
<b>N.</b>	Dump height, ft/in (mm)	8' 8" (2653)
<b>O.</b>	Max dump angle	41°
<b>P.</b>	Reach @ 45 degree dump angle, ft/in (mm)	2' 7" (797)
	Max grading angle	116°

Unit equipped with 12-16.5 front tire, 19.5L-24 rear tire

LOADER PERFORMANCE	
	<b>1.1 cu yd Heavy-Duty General Purpose</b>
Linkage geometry	straight
Bucket breakout force, lbf (daN)	12,004 (6340)
Lift capacity to full height, lbs (kg)	7996 (3627)
SAE heaped capacity, cu yd (m³)	1.1 (.88)
SAE struck capacity, cu yd (m³)	.91 (.73)
Bucket weight, lbs (kg)	682 (309)
Cutting width, in (mm)	88 (2250)
Cycle	
Raise to full height	3.70 sec
Dump time	1.90 sec
Lower	2.70 sec

WEIGHT	
Base Unit (4WD, Cab)	17,560 lbs
With options added	
2WD	-386 lbs
Canopy	-397 lbs
4x1	+969 lbs
6x1	+1408 lbs
Std. (counterweight)	-700 lbs
Med. (counterweight)	-170 lbs

TRANSMISSION		
	<b>Power Shuttle</b>	<b>Powershift</b>
Manufacturer	Carraro	Carraro
Transmission type	Synchromesh	Hydraulic clutch packs
Gear	4F/4R	4F/3R
Max Fwd travel speed, mph (kph)	22.5 (36.2)	22.1 (35.5)

Note: Travel Speeds with 19.5L-24 Rear Tires

ENGINE	
Make and model	F5BFL413B*B
Type	Tier 4 Final certified, Diesel Oxidation Catalyst with Urea Dosing Module and Selective Catalytic Reduction, HPCR, 4-cycle diesel
Aspiration	Turbocharged Aftercooled
Rated RPM	2200
Number of cylinders	4
Displacement, cu in (l)	207 (3.4)
Horsepower, gross, hp (kW)	97 (72)
Horsepower, net hp (kW)	95 (71)
Peak torque, lb-ft (Nm) @ RPM	338 (452) @ 1400

MANEUVERABILITY		
	<b>Less Brakes</b>	<b>With Split Brakes</b>
2WD curb clearance	13' 6"	12' 7"
4WD curb clearance	15' 9"	11' 5"
2WD bucket clearance	17' 9"	16' 8"
4WD bucket clearance	19' 5"	16' 6"

\*4WD, CAB, HED, Heavy Duty Counterweight, STD Bucket

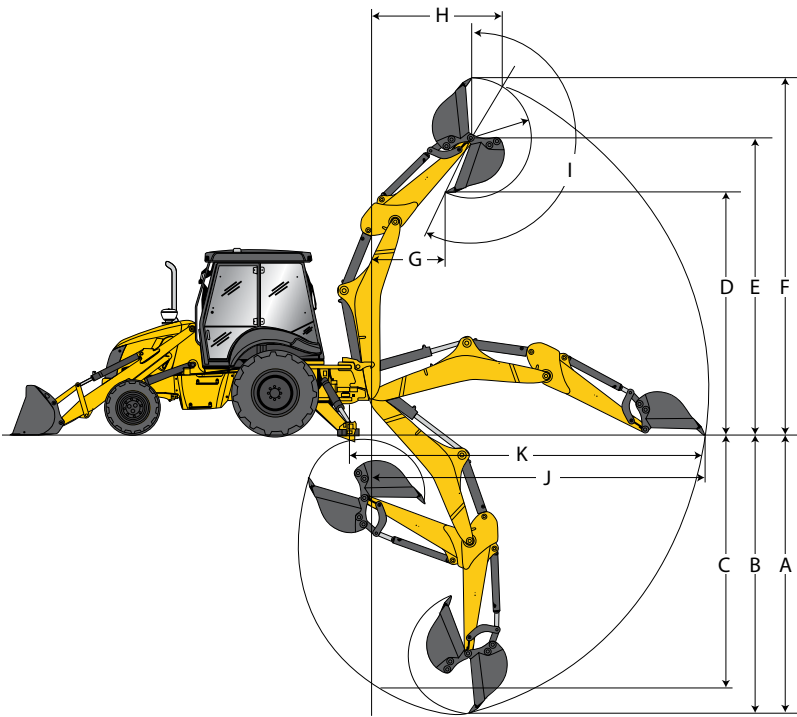

#### BACKHOE DIMENSIONS

		Standard	Retracted	Extended
<b>A</b>	Max dig depth, ft/in (mm)	14' 5" [4385]	15' 8" [4595]	18' 6" [5627]
<b>B</b>	Dig depth, 2' level bottom, ft/in (mm)	14' 3" [4344]	14' 11" [4547]	18' 4" [5578]
<b>C</b>	Dig depth, 8' level bottom, ft/in (mm)	13' 1" [3988]	13' 9" [4191]	17' 5" [5298]
<b>D</b>	Loading Height, ft/in (mm)	11' 9" [3570]	12' 1" [3681]	14' 2" [4324]
<b>E</b>	Max pin height, ft/in (mm)	14' 9" [4503]	15' 2" [4611]	17' 3" [5254]
<b>F</b>	Max operating height, ft/in (mm)	17' 5" [5318]	17' 9" [5411]	19' 10" [6055]
<b>G</b>	Loading Reach @ max height, ft/in (mm)	6' 9" [2053]	4' 10" [2133]	7' 0" [2978]
<b>H</b>	Dig reach @ max height, ft/in (mm)	8' 5" [2562]	8' 11" [2706]	11' 8" [3550]
<b>I</b>	Bucket rotation (max)	200°	200°	200°
<b>J</b>	Reach from swing post, ft/in (mm)	17' 0" [5186]	17' 6" [5327]	20' 7" [6279]
<b>K</b>	Reach (overall), ft/in (mm)	18' 5" [5612]	17' 7" [5355]	20' 8" [6286]

#### BACKHOE PERFORMANCE

	Standard	Retracted	Extended
Bucket capacity, cu ft (m <sup>3</sup> )	7.5 (.21)	7.5 (.21)	7.5 (.21)
Bucket digging force, lbs (kg)	12,933 (5866)	12,933 (5866)	12,933 (5866)
Crowd digging force, lbs (kg)	8588 (3895)	8100 (3674)	5782 (2623)
Boom lift @ -8 ft, lbs (kg)	3234 (1467)	2738 (1242)	2332 (1058)
Dipper lift @ +10 ft, lbs (kg)	5342 (2423)	5831 (2645)	3885 (1762)

#### HYDRAULIC SYSTEM

Pilot Control Pump	Variable displacement
System type	Open center
Main pump type	Dual gear
Pump capacity gpm (lpm)	40 (151)
System relief pressure	3045 psi

#### ELECTRICAL

Alternator output	160 amps
Battery capacity (std/opt)	1200/900 CCA

#### REFILL CAPACITIES

Fuel tank, gal (l)	34.6 (131)
DEF system, gal (l)	3.5 (13.2)
Cooling system, gal (l)	6.3 (23.8)
Engine oil, includes filter, gal (l)	2.1 (8.0)
Hydraulic tank, gal (l)	13.4 (50.7)
Hydraulic system, gal (l)	37 (142)

#### CYLINDER SPECS

Loader cylinder	3.54" bore x 28.62" stroke
Backhoe	
Boom cylinder	5" bore x 35.71" stroke
Arm cylinder	4.75" bore x 27.64" stroke
Bucket cylinder	3.5" bore x 30.16" stroke
Swing cylinder	4.33" bore x 9.38" stroke

#### SERVICE INTERVALS

Engine oil	500 hours
Hydraulic oil filter	1000 hours
Engine coolant	2000 hours
Rear axle oil	1000 hours

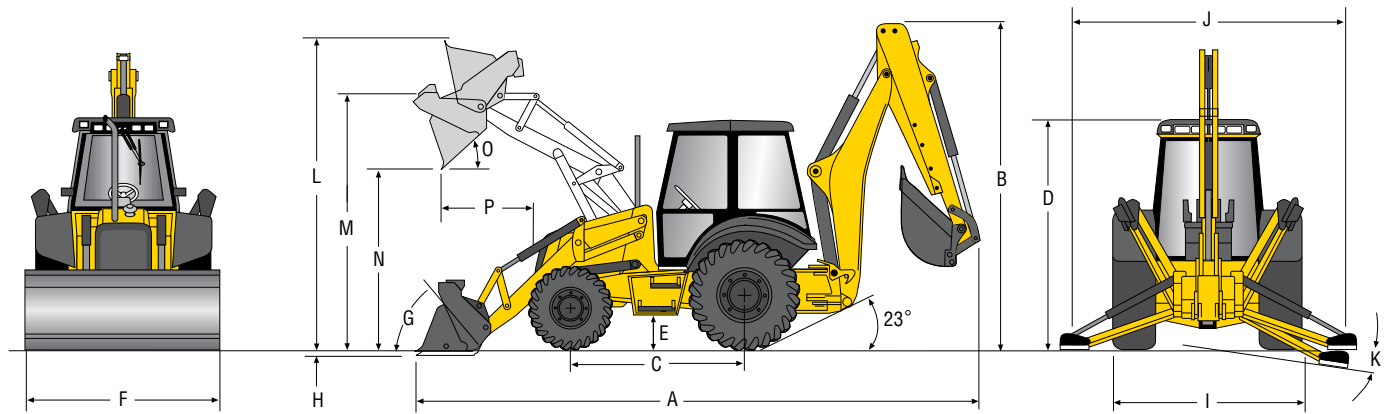

DIMENSIONS			
<b>A.</b>	Transport length, ft/in (mm)	23' 6" (7159)	
<b>B.</b>	Transport height, ft/in (mm)	12' 9" (3879)	
<b>C.</b>	Wheelbase, ft/in (mm)		
	2WD	7' 2" (2178)	
	4WD	7' 2" (2178)	
<b>D.</b>	Height to top of cab, ft/in (mm)	9' 5" (2862)	
<b>E.</b>	Ground Clearance, in (mm)	13 (341)	
<b>F.</b>	Blade width, ft/in (mm)	7' 5" (2248)	
<b>G.</b>	Bucket Rollback		
	At ground level		43°
	Raised		Adjustable
<b>H.</b>	Digging depth below grade, in (mm)		9 (219)
<b>I.</b>	Transport width, ft/in (mm)		7' 7" (2318)
<b>J.</b>	Stabilizer spread, operating, ft/in (mm)		10' 7" (3226)
<b>K.</b>	Stabilizer spread, leveling angle		14°

LOADER DIMENSIONS		
		<b>1.3 cu yd Heavy-Duty General Purpose</b>
<b>L.</b>	Max operating height, ft/in (mm)	14' 5" (4384)
<b>M.</b>	Height to hinge pin, ft/in (mm)	11' 1" (3384)
<b>N.</b>	Dump height, ft/in (mm)	8' 4" (2551)
<b>O.</b>	Max dump angle	45°
<b>P.</b>	Reach @ 45 degree dump angle, ft/in (mm)	2' 8" (824)
	Max grading angle	116°

Unit equipped with 12-16.5 front tire, 19.5L-24 rear tire

LOADER PERFORMANCE		
		<b>1.3 cu yd Heavy-Duty General Purpose</b>
Linkage geometry		curved
Bucket breakout force, lbf (daN)		14,711 (6544)
Lift capacity to full height, lbs (kg)		7606 (3450)
SAE heaped capacity, cu yd (m <sup>3</sup> )		1.3 (1.0)
SAE struck capacity, cu yd (m <sup>3</sup> )		0.8 (1.05)
Bucket weight, lbs (kg)		1043 (473)
Cutting width, in (mm)		89 (2248)
Cycle		
Raise to full height		3.70 sec
Dump time		1.90 sec
Lower		2.70 sec

WEIGHT	
Base Unit (4WD, Cab), lbs (kg)	17,703 (8030)
With options added	
2WD	-386 lbs
Canopy	-397 lbs
4x1	+770 lbs
6x1	+1810 lbs
Std. (counterweight)	-700 lbs
Med. (counterweight)	-170 lbs

TRANSMISSION		
	<b>Power Shuttle</b>	<b>Powershift</b>
Manufacturer	Carraro	Carraro
Transmission type	Synchromesh	Hydraulic clutch packs
Gear	4F/4R	4F/3R
Max Fwd travel speed, mph (kph)	22.5 (36.2)	22.1 (35.5)

Note: Travel Speeds with 19.5L-24 Rear Tires

ENGINE	
Make and model	F5BFL413B*B003
Type	Tier 4 Final certified, Diesel Oxidation Catalyst with Urea Dosing Module and Selective Catalytic Reduction, HPCR, 4-cycle diesel
Aspiration	Turbocharged Aftercooled
Rated RPM	2200 RPM
Number of cylinders	4
Displacement, cu in (l)	207 (3.4)
Horsepower, gross, hp (kW)	97 (72)
Horsepower, net hp (kW)	95 (71)
Peak torque, lb-ft (Nm) @ RPM	338 (458) @ 1400

MANEUVERABILITY		
	<b>Less Brakes</b>	<b>With Split Brakes</b>
2WD curb clearance	13' 6"	12' 7"
4WD curb clearance	15' 9"	11' 5"
2WD bucket clearance	17' 9"	16' 8"
4WD bucket clearance	19' 5"	16' 6"

\*4WD, CAB, HED, Heavy Duty Counterweight, STD Bucket

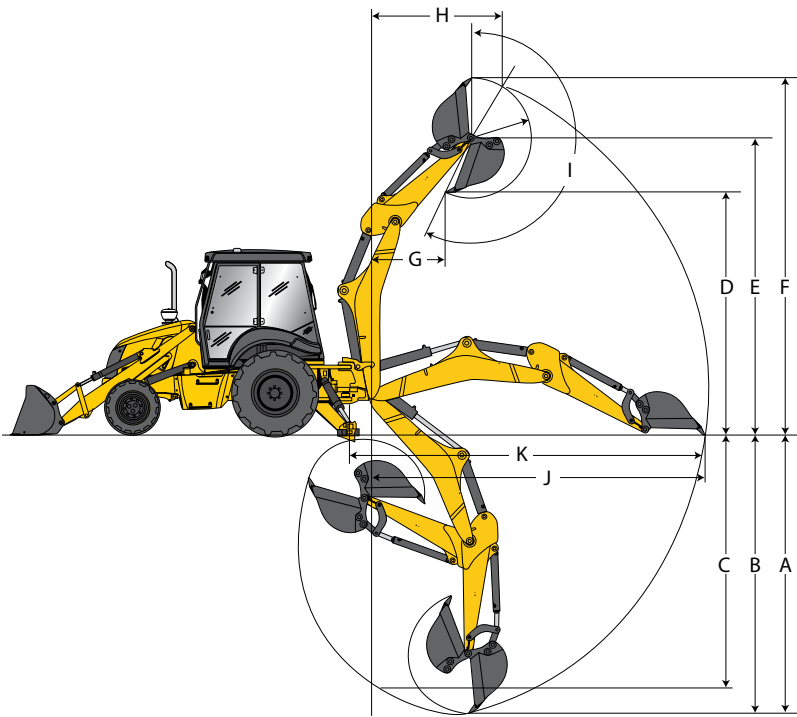

HYDRAULIC SYSTEM	
Pilot Control Pump	Variable displacement
System type	Open center
Main pump type	Dual gear
Pump capacity gpm (lpm)	40 (151)
System relief pressure	3045 psi

ELECTRICAL	
Alternator output	160 amps
Battery capacity (std/opt)	1200/900 CCA

REFILL CAPACITIES	
Fuel tank, gal (l)	34.6 (131)
DEF system, gal (l)	3.5 (13.2)
Cooling system, gal (l)	6.4 (24)
Engine oil, includes filter, gal (l)	2.1 (8.0 L)
Hydraulic tank, gal (l)	13.4 (50.7)
Hydraulic system, gal (l)	29 (111)

CYLINDER SPECS	
Loader cylinder	3.54" bore x 28.6" stroke
Backhoe	
Boom cylinder	5" bore x 35.71" stroke
Arm cylinder	4.75" bore x 27.64" stroke
Bucket cylinder	3.5" bore x 30.16" stroke
Swing cylinder	4.33" bore x 9.38" stroke

SERVICE INTERVALS	
Engine oil	500 hours
Hydraulic oil filter	1000 hours
Engine coolant	2000 hours
Rear axle oil	1000 hours

BACKHOE DIMENSIONS				
		Standard	Retracted	Extended
<b>A</b>	Max dig depth, ft/in (mm)	14' 5" (4385)	15' 1" (4595)	18' 6" (5627)
<b>B</b>	Dig depth, 2' level bottom, ft/in (mm)	14' 3" (4344)	14' 11" (4547)	18' 4" (5578)
<b>C</b>	Dig depth, 8' level bottom, ft/in (mm)	13' 1" (3988)	13' 9" (4191)	17' 5" (5298)
<b>D</b>	Loading Height, ft/in (mm)	11' 9" (3570)	12' 1" (3681)	14' 2" (4324)
<b>E</b>	Max pin height, ft/in (mm)	14' 9" (4503)	15' 2" (4611)	17' 3" (5254)
<b>F</b>	Max operating height, ft/in (mm)	17' 10" (5425)	18' 2" (5529)	20' 3" (6173)
<b>G</b>	Loading Reach @ max height, ft/in (mm)	5' 7" (1707)	5' 11" (1794)	8' 8" (2638)
<b>H</b>	Dig reach @ max height, ft/in (mm)	8' 5" (2562)	8' 11" (2706)	11' 8" (3550)
<b>I</b>	Bucket rotation (max)	204°	204°	204°
<b>J</b>	Reach from swing post, ft/in (mm)	18' 4" (5579)	17' 6" (5323)	20' 9" (6313)
<b>K</b>	Reach (overall), ft/in (mm)	18' 5" (5612)	17' 7" (5355)	20' 8" (6286)

BACKHOE PERFORMANCE			
	Standard	Retracted	Extended
Bucket capacity, cu ft (m <sup>3</sup> )	7.5 (.21)	7.5 (.21)	7.5 (.21)
Bucket digging force, lbs (kg)	12,933 (5866)	12,933 (5866)	12,933 (5866)
Crowd digging force, lbs (kg)	8588 (3895)	8100 (3674)	5782 (2623)
Boom lift @ -8 ft, lbs (kg)	3228 (1467)	2732 (1242)	2329 (1058)
Dipper lift @ +10 ft, lbs (kg)	5342 (2423)	5831 (2645)	3885 (1762)

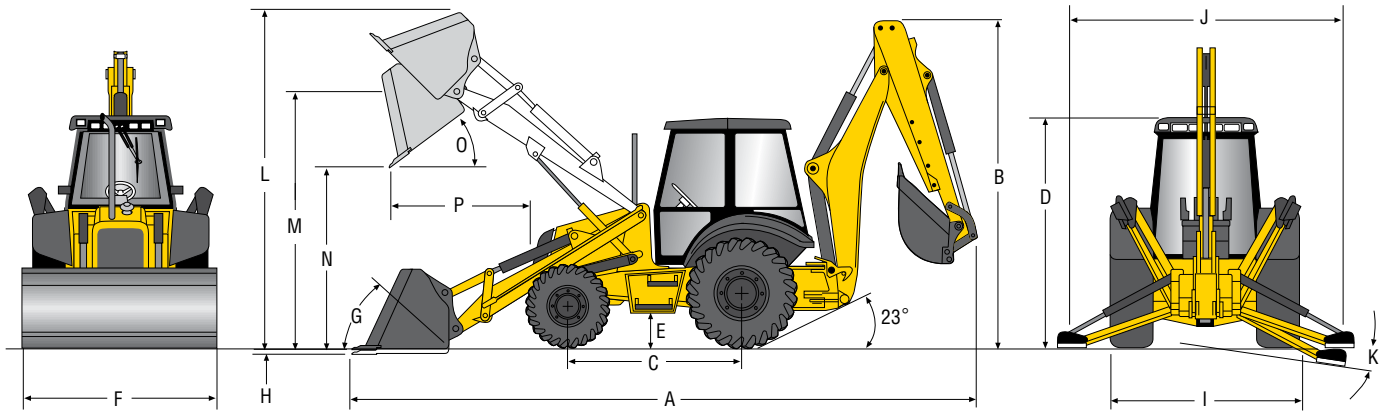

DIMENSIONS			
<b>A.</b>	Transport length, ft/in (mm)	23' 9" (7234)	
<b>B.</b>	Transport height, ft/in (mm)	12' 9" (3893)	
<b>C.</b>	Wheelbase, in (mm)		
	2WD	85.8 (2180)	
	4WD	85.8 (2180)	
<b>D.</b>	Height to top of cab, ft/in (mm)	9' 2" (2805)	
<b>E.</b>	Ground Clearance, in (mm)	11.8 (300)	
<b>F.</b>	Blade width, ft/in (mm)	7' 5" (2250)	
<b>G.</b>	Bucket Rollback		
	At ground level		43°
	Raised		55°
<b>H.</b>	Digging depth below grade, in (mm)		4" (100)
<b>I.</b>	Transport width, ft/in (mm)		8' 1" (2484)
<b>J.</b>	Stabilizer spread, operating, ft/in (mm)		10' 7" (3226)
<b>K.</b>	Stabilizer spread, leveling angle		14°

LOADER DIMENSIONS		
		<b>1.1 cu yd Heavy-Duty General Purpose</b>
<b>L.</b>	Max operating height, ft/in (mm)	14' 0" (4276)
<b>M.</b>	Height to hinge pin, ft/in (mm)	11' 1" (3384)
<b>N.</b>	Dump height, ft/in (mm)	9' 2" (2784)
<b>O.</b>	Max dump angle	45°
<b>P.</b>	Reach @ 45 degree dump angle, ft/in (mm)	2' 5" (725)
	Max grading angle	116°

Unit equipped with 12-16.5 front tire, 19.5L-24 rear tire

LOADER PERFORMANCE		
		<b>1.1 cu yd Heavy-Duty General Purpose</b>
Linkage geometry		straight
Bucket breakout force, lbf (daN)		12,004 (6340)
Lift capacity to full height, lbs (kg)		7996 (3627)
SAE heaped capacity, cu yd (m <sup>3</sup> )		1.1 (.88)
SAE struck capacity, cu yd (m <sup>3</sup> )		.91 (.73)
Bucket weight, lbs (kg)		682 (309)
Cutting width, in (mm)		88 (2250)
Cycle		
Raise to full height		3.70 sec
Dump time		2.00 sec
Lower		2.60 sec

WEIGHT	
Base Unit (4WD, Cab, HED, 6x1)	18,805 lbs
With options added	
2WD	-386 lbs
Canopy	-100 lbs
4x1	+1708 lbs
6x1	+2170 lbs
Std. (counterweight)	NA
Med. (counterweight)	NA

TRANSMISSION		
	<b>Power Shuttle</b>	<b>Powershift</b>
Manufacturer	Carraro	Carraro
Transmission type	Synchromesh	Hydraulic clutch packs
Gear	4F/4R	4F/3R
Max Fwd travel speed, mph (kph)	22.5 (36.2)	22.1 (35.5)

Note: Travel Speeds with 19.5L-24 Rear Tires

ENGINE	
Make and model	F5BFL413B*B003
Type	Tier 4 Final certified, Diesel Oxidation Catalyst with Urea Dosing Module and Selective Catalytic Reduction, HPCR, 4-cycle diesel
Aspiration	Turbocharged Aftercooled
Rated RPM	2200
Number of cylinders	4
Displacement, cu in (l)	207 (3.4)
Horsepower, gross, hp (kW)	97 (72)
Horsepower, net hp (kW)	95 (71)
Peak torque, lb-ft (Nm) @ RPM	338 (452) @ 1400

MANEUVERABILITY		
	<b>Less Brakes</b>	<b>With Split Brakes</b>
2WD curb clearance	13' 6"	12' 7"
4WD curb clearance	15' 9"	11' 5"
2WD bucket clearance	17' 9"	16' 8"
4WD bucket clearance	19' 5"	16' 6"

\*4WD, CAB, HED, Heavy Duty Counterweight, STD Bucket



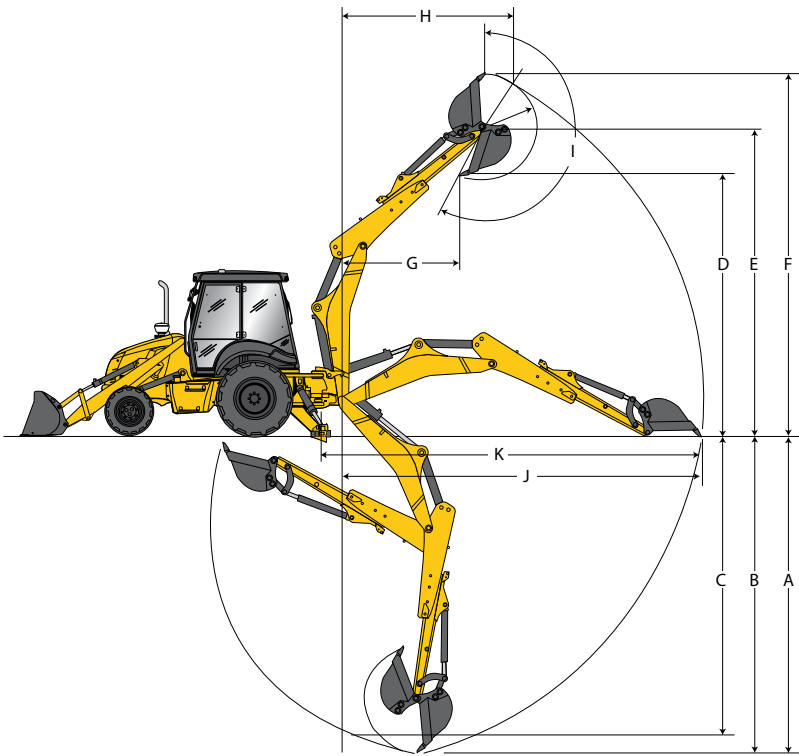

#### HYDRAULIC SYSTEM

Pilot Control Pump	Variable displacement
System type	Open center
Main pump type	Dual gear
Pump capacity gpm (lpm)	40 (151)
System relief pressure	3045 psi

#### ELECTRICAL

Alternator output	160 amps
Battery capacity (std/opt)	1200/900 CCA

#### REFILL CAPACITIES

Fuel tank, gal (l)	34.6 (131)
DEF system, gal (l)	3.5 (13.2)
Cooling system, gal (l)	6.4 (24)
Engine oil, includes filter, gal (l)	2.1 (8.0)
Hydraulic tank, gal (l)	13.4 (50.7)
Hydraulic system, gal (l)	29 (111)

#### CYLINDER SPECS

Loader cylinder	3.54" bore x 28.6" stroke
Backhoe	
Boom cylinder	5" bore x 35.71" stroke
Arm cylinder	4.75" bore x 27.64" stroke
Bucket cylinder	3.5" bore x 30.16" stroke
Swing cylinder	4.33" bore x 9.38" stroke

#### SERVICE INTERVALS

Engine oil	500 hours
Hydraulic oil filter	1000 hours
Engine coolant	2000 hours
Rear axle oil	1000 hours

#### BACKHOE DIMENSIONS

		Standard	Retracted	Extended
<b>A</b>	Max dig depth, ft/in (mm)	15' 3" [4666]	15' 1" [4595]	18' 5" [5613]
<b>B</b>	Dig depth, 2' level bottom, ft/in (mm)	15' 2" [4632]	14' 11" [4547]	18' 4" [5578]
<b>C</b>	Dig depth, 8' level bottom, ft/in (mm)	14' 1" [4191]	13' 9" [4191]	17' 5" [5298]
<b>D</b>	Loading Height, ft/in (mm)	12' 4" [3867]	12' 4" [3781]	14' 6" [4424]
<b>E</b>	Max pin height, ft/in (mm)	15' 4" [4693]	15' 1" [4611]	17' 3" [5254]
<b>F</b>	Max operating height, ft/in (mm)	18' 5" [5624]	18' 6" [5625]	20' 7" [6285]
<b>G</b>	Loading Reach @ max height, ft/in (mm)	6' 3" [1904]	5' 10" [1794]	8' 8" [2638]
<b>H</b>	Dig reach @ max height, ft/in (mm)	8' 2" [2489]	7' 10" [2394]	10' 7" [3238]
<b>I</b>	Bucket rotation (max)	203°	203°	203°
<b>J</b>	Reach from swing post, ft/in (mm)	17' 11" [5450]	17' 11" [5456]	21' 0" [6409]
<b>K</b>	Reach (overall), ft/in (mm)	19' 3" [5853]	19' 3" [5859]	22' 4" [6814]

#### BACKHOE PERFORMANCE

	Standard	Retracted	Extended
Bucket capacity, cu ft (m <sup>3</sup> )	8.5 (.24)	8.5 (.24)	8.5 (.24)
Bucket digging force, lbs (kg)	12,933 (5755)	12,933 (5755)	12,933 (5755)
Crowd digging force, lbs (kg)	8520 (3868)	8483 (3848)	6032 (2736)
Boom lift @ -8 ft, lbs (kg)	3432 (1560)	3047 (1385)	2159 (1145)
Dipper lift @ +10 ft, lbs (kg)	4059 (1845)	3784 (1720)	2673 (1215)

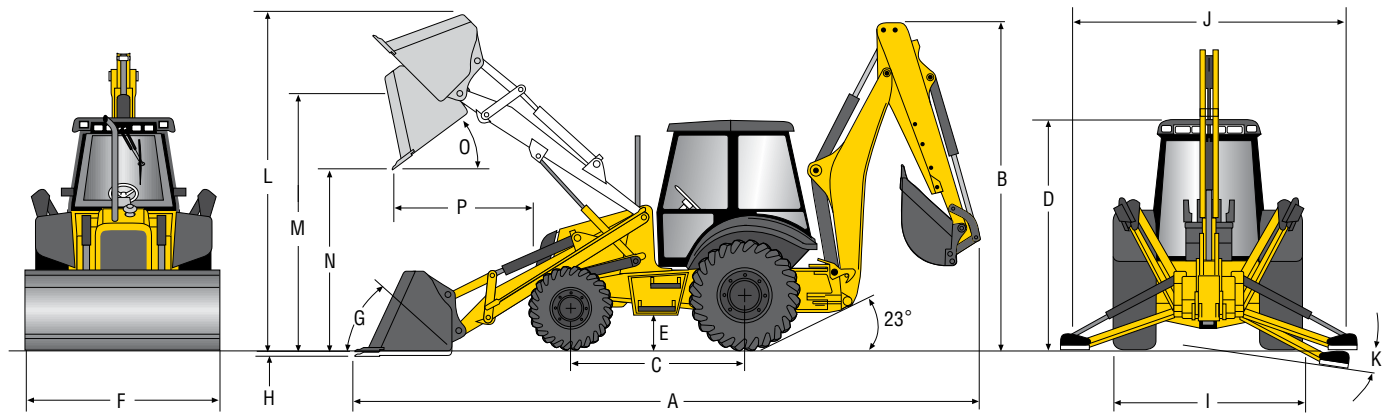

DIMENSIONS			
<b>A.</b>	Transport length, ft/in (mm)	23' 9" (7234)	
<b>B.</b>	Transport height, ft/in (mm)	12' 6" (3810)	
<b>C.</b>	Wheelbase, in (mm)		
	2WD	86 (2180)	
	4WD	86 (2180)	
<b>D.</b>	Height to top of cab, ft/in (mm)	9' 3" (2805)	
<b>E.</b>	Ground Clearance, in (mm)	12 (300)	
<b>F.</b>	Blade width, ft/in (mm)	7' 5" (2248)	
<b>G.</b>	Bucket Rollback		
	At ground level		43°
	Raised		55°
<b>H.</b>	Digging depth below grade, in (mm)		9" (234)
<b>I.</b>	Transport width, ft/in (mm)		7' 6" (2300)
	Overall width, ft/in (mm)		
	Ground pads		7' 7" (2318)
	Reversible pads		8' 2" (2484)
<b>J.</b>	Stabilizer spread, operating, ft/in (mm)		10' 7" (3226)
<b>K.</b>	Stabilizer spread, leveling angle		14°

LOADER DIMENSIONS		
		<b>1.1 cu yd Heavy-Duty General Purpose</b>
<b>L.</b>	Max operating height, ft/in (mm)	14' 5" (4400)
<b>M.</b>	Height to hinge pin, ft/in (mm)	13' 10" (3976)
<b>N.</b>	Dump height, ft/in (mm)	8' 9" (2653)
<b>O.</b>	Max dump angle	45°
<b>P.</b>	Reach @ 45 degree dump angle, ft/in (mm)	2' 7" (797)
	Max grading angle	116°

Unit equipped with 12-16.5 front tire, 19.5L-24 rear tire

LOADER PERFORMANCE		
		<b>1.3 cu yd Heavy-Duty General Purpose</b>
Linkage geometry		straight
Bucket breakout force, lbf (daN)		14,253 (6340)
Lift capacity to full height, lbs (kg)		7833 (3553)
SAE heaped capacity, cu yd (m³)		1.3 (1.0)
SAE struck capacity, cu yd (m³)		1.1 (.82)
Bucket weight, lbs (kg)		880 (399)
Cutting width, in (mm)		89 (2250)
Cycle		
Raise to full height		3.7 sec
Dump time		1.9 sec
Lower		2.7 sec

WEIGHT	
Base Unit (4WD, Cab, HED)	18,525 lbs
With options added	
2WD	-386 lbs
Canopy	-397 lbs
4x1	+969 lbs
6x1	+1408 lbs
Std. (counterweight)	-700 lbs
Med. (counterweight)	-170 lbs

TRANSMISSION		
	<b>Power Shuttle</b>	<b>Powershift</b>
Manufacturer	Carraro	Carraro
Transmission type	Synchromesh	Hydraulic clutch packs
Gear	4F/4R	4F/3R
Max Fwd travel speed, mph (kph)	22.5 (36.2)	23.4 (37.7)

Note: Travel Speeds with 19.5L-24 Rear Tires

ENGINE	
Make and model	F5HFL413A*B
Type	Tier 4 Final certified, Diesel Oxidation Catalyst with Urea Dosing Module and Selective Catalytic Reduction, HPCR, 4-cycle diesel
Aspiration	Turbocharged Aftercooled
Rated RPM	2200 RPM
Number of cylinders	4
Displacement, cu in (l)	207 (3.4)
Horsepower, gross, hp (kW)	110 (82)
Horsepower, net hp (kW)	108 (81)
Peak torque, lb-ft (Nm) @ RPM	339 (460) @ 1400

MANEUVERABILITY		
	<b>Less Brakes</b>	<b>With Split Brakes</b>
2WD curb clearance	13' 6"	12' 7"
4WD curb clearance	15' 9"	11' 5"
2WD bucket clearance	17' 9"	16' 8"
4WD bucket clearance	19' 5"	16' 6"

\*4WD, CAB, HED, Heavy Duty Counterweight, STD Bucket

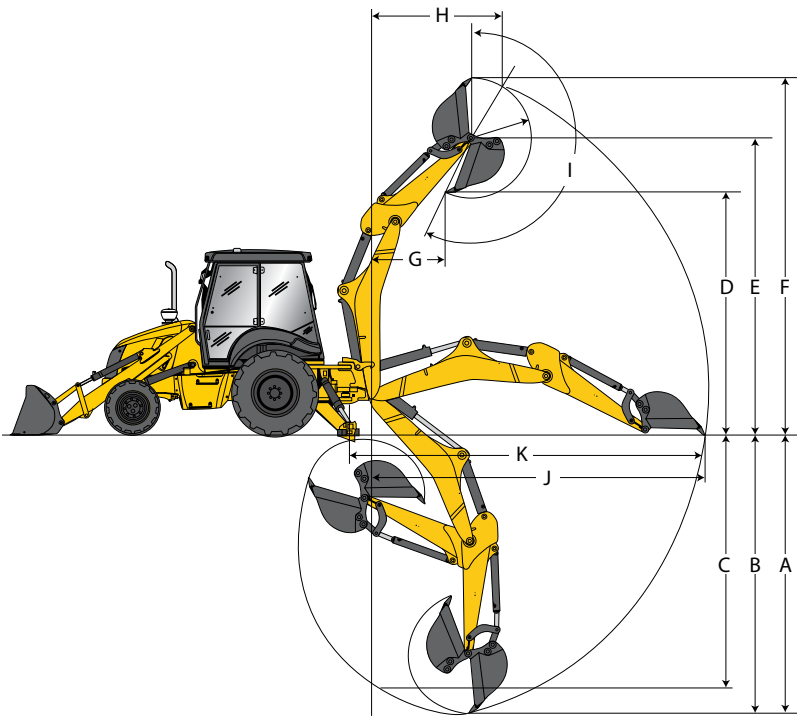

HYDRAULIC SYSTEM	
Pilot Control Pump	Variable displacement
System type	Open center
Main pump type	Dual gear
Pump capacity gpm (lpm)	40 (151)
System relief pressure	3045 psi

ELECTRICAL	
Alternator output	160 amps
Battery capacity (std/opt)	1200/900 CCA

REFILL CAPACITIES	
Fuel tank, gal (l)	34.6 (131)
DEF system, gal (l)	3.5 (13.2)
Cooling system, gal (l)	6.4 (24)
Engine oil, includes filter, gal (l)	2.1 (8.0)
Hydraulic tank, gal (l)	13.4 (50.7)
Hydraulic system, gal (l)	37 (142)

CYLINDER SPECS	
Loader cylinder	3.54" bore x 28.6" stroke
Backhoe	
Boom cylinder	5" bore x 35.71" stroke
Arm cylinder	4.75" bore x 27.64" stroke
Bucket cylinder	3.5" bore x 30.16" stroke
Swing cylinder	4.33" bore x 9.38" stroke

SERVICE INTERVALS	
Engine oil	500 hours
Hydraulic oil filter	1000 hours
Engine coolant	2000 hours
Rear axle oil	1000 hours

BACKHOE DIMENSIONS				
		Standard	Retracted	Extended
<b>A</b>	Max dig depth, ft/in (mm)	15' 4" (4666)	15' 5" (4692)	19' 4" (5881)
<b>B</b>	Dig depth, 2' level bottom, ft/in (mm)	15' 2" (4632)	15' 4" (4660)	19' 2" (5849)
<b>C</b>	Dig depth, 8' level bottom, ft/in (mm)	14' 1" (4291)	14' 2" (4323)	18' 4" (5586)
<b>D</b>	Loading Height, ft/in (mm)	12' 4" (3763)	12' 4" (3769)	14' 9" (4500)
<b>E</b>	Max pin height, ft/in (mm)	16' 4" (4969)	15' 5" (4698)	17' 7" (5359)
<b>F</b>	Max operating height, ft/in (mm)	15' 5" (4693)	15' 5" (4699)	17' 10" (5430)
<b>G</b>	Loading Reach @ max height, ft/in (mm)	7' 5" (2252)	7' 5" (2255)	10' 7" (3220)
<b>H</b>	Dig reach @ max height, ft/in (mm)	8' 6" (2579)	9' 4" (2832)	12' 5" (3796)
<b>I</b>	Bucket rotation (max)	200°	200°	200°
<b>J</b>	Reach from swing post, ft/in (mm)	19' 2" (5831)	19' 3" (5859)	22' 10" (6965)
<b>K</b>	Reach (overall), ft/in (mm)	19' 3" (5862)	19' 4" (5890)	22' 11" (6991)

BACKHOE PERFORMANCE			
	Standard	Retracted	Extended
Bucket capacity, cu ft (m <sup>3</sup> )	8.5 (.24)	8.5 (.24)	8.5 (.24)
Bucket digging force, lbs (kg)	13,418 (6086)	13,418 (6086)	13,418 (6086)
Crowd digging force, lbs (kg)	8520 (3868)	8483 (3848)	6032 (2736)
Boom lift @ -8 ft, lbs (kg)	3439 (1560)	3053 (1385)	2535 (1150)
Dipper lift @ +10 ft, lbs (kg)	4431 (2010)	4167 (1890)	3274 (1485)

**B75D BASE EQUIPMENT****ENGINE**

Dry dual-element air cleaner  
 Fuel filter w/ water separator  
 10 micron paper filter  
 Glow Plugs  
 FPT F5BFL413B Diesel  
 Diesel Oxidation Catalyst  
 Full flow engine oil filter  
 Electronic throttles – foot and rotary hand  
 Self-adjusting belt  
 High Pressure Common Rail

**TRANSMISSION**

Power shuttle fully synchronized gear-box, 4 forward/4 reverse speeds, and power-reversing torque converter  
 Two position electric disconnect on loader control and gearshift

**OUTBOARD REAR AXLE/BRAKES**

Planetary final drives  
 Multi-plate, hydraulic, self-adjusting, self-equalizing outboard wet disc  
 Mechanical parking brake

**FRONT AXLE**

8-bolt wheel hubs  
 Power steering pump  
 Integrated steering cylinder  
 FWD axle: cast iron  
 FWD electrical engagement with indicator light

**ELECTRICAL**

12-volt system  
 160-amp high-capacity alternator  
 Single battery  
 Sealed fuseblock compartment  
 Water resistant main fuseblock

**LIGHTING**

8 Halogen worklights on cab  
 Stop and turn signals  
 Four-way safety flashers

**BACKHOE**

Includes: Standard 14-ft curved boom, Center pivot swing post, Boom cylinder, and Dipper cylinder  
 Dipper cylinder and dipstick  
 2-lever backhoe controls (SAE Pattern)  
 Reversible stabilizer pads  
 Front counterweight - 282 lbs.  
 Backhoe bucket not included

**OPERATOR'S STATION (ROPS)**

Dual side entry flat deck  
 Interior rearview mirror  
 Built-in beverage holder  
 Key start switch with electric shut-off  
 Dual horn buttons-front and rear  
 Electric analog instrumentation

Tachometer/hour meter  
 Fuel gauge  
 Fixed steering wheel  
 Auxiliary 12-volt output/cigarette lighter  
 USB charge port  
 Pre-wired for emergency beacon  
 Vinyl suspension seat  
 2-inch retractable seatbelt

**OPERATOR'S STATION (CAB)**

Dual side entry flat deck  
 Interior rearview mirror  
 Built-in beverage holder  
 Radio Ready  
 Key start switch with electric shut-off  
 Headliner  
 2-position horn control  
 Molded floor mat  
 Electric instrumentation  
 Tachometer/hour meter  
 Fuel gauge  
 Interior dome light  
 Fixed steering wheel  
 USB charge port  
 Pre-wired for emergency beacon  
 Adjustable side window openings  
 One-piece rear window  
 Adjustable heater/blower fan  
 Adjustable front sun-screen shade  
 Cloth suspension seat  
 2-inch retractable seatbelt  
 Heater and Air Conditioning

**LOADER**

Straight loader arm design (SLA)  
 4-Bar bucket linkage  
 Bucket level indicator  
 Dual lift and bucket cylinders  
 Single lever control  
 Loader arm support  
 1.3 yd<sup>3</sup> heavy duty bucket  
 Welded on cutting edge

**HYDRAULICS**

O-ring Face seal connectors  
 Belt driven pump drive  
 7 micron spin-on filter element  
 Mechanical, Gear Pump - 123 L/min (32.49 gpm)  
 One-way rear hammer circuit w/ pedal

**SAFETY AND SECURITY**

4-Post ROPS/FOPS  
 Lockable Compartments for: Engine, Hydraulic System, Battery  
 Lockable fuel cap  
 Horn  
 Backup alarm  
 Toolbox with lock and key

**B75D OPTIONAL EQUIPMENT****BACKHOE**

HED extendible dipperstick  
 Multiple bucket options from factory  
 Heavy-duty and extra heavy-duty back-hoe buckets

**OPERATOR'S STATION (CAB)**

Air conditioning system  
 3-inch retractable seatbelt

**LOADER**

Multiple buckets available

**HYDRAULICS**

3<sup>rd</sup> spool aux hydraulics for loader

**TOTAL VEHICLE**

Front fenders

**LOADER ATTACHMENTS**

Sweeper brooms  
 4x1 bucket  
 Auger  
 Forks  
 Scrap grapple

**BACKHOE ATTACHMENTS**

Hydraulic breaker  
 Additional buckets

**TIRES**

Please see your dealer to discuss the other tire options available.

**B95D B95D TC B95D LR BASE EQUIPMENT****ENGINE**

Dry dual-element air cleaner  
 Fuel filter w/ water separator  
 10 micron paper filter  
 Glow Plugs  
 FPT F5BFL413B Diesel  
 Diesel Oxidation Catalyst with SCR  
 Full flow engine oil filter  
 Electronic throttles – foot and rotary hand  
 Self-adjusting belt  
 High Pressure Common Rail

**TRANSMISSION**

Power shuttle fully synchronized gear-  
 box, 4 forward/4 reverse speeds, and  
 power-reversing torque converter  
 Two position electric disconnect on  
 loader control and gearshift

**OUTBOARD REAR AXLE/BRAKES**

Planetary final drives  
 Button activated differential lock  
 Multi-plate, hydraulic, self-adjusting,  
 self-equalizing outboard wet disc  
 brakes  
 Independent SAHR parking/emergency  
 brake

**FRONT AXLE**

74" tread width  
 8-bolt wheel hubs  
 Hydrostatic power steering with  
 priority valve  
 Integrated steering cylinder  
 2WD axle: cast iron  
 FWD axle: cast iron  
 FWD electrical engagement with  
 indicator light

**ELECTRICAL**

12-volt system  
 160-amp high-capacity alternator  
 Single battery  
 Sealed fuseblock compartment  
 Water resistant main fuseblock

**LIGHTING**

4 Halogen worklights on canopy  
 8 Halogen worklights on cab  
 Stop and turn signals  
 Four-way safety flashers

**BACKHOE**

Includes: Standard 14-ft curved boom,  
 Center pivot swing post, Boom  
 cylinder, and Dipper cylinder  
 Dipper cylinder and dipstick  
 2-lever backhoe controls (SAE Pattern)  
 Dirt pads  
 Front counterweight - 282 lbs.  
 Backhoe bucket not included

**OPERATOR'S STATION (ROPS)**

Dual side entry flat deck  
 Interior rearview mirror  
 Built-in beverage holder  
 Key start switch with electric shut-off  
 2-position horn control  
 Electric analog instrumentation  
 Tachometer/hourmeter  
 Fuel gauge  
 DEF gauge

Fixed steering wheel  
 Auxiliary 12-volt output/cigarette lighter  
 Pre-wired for emergency beacon  
 Pre-wired for road headlights  
 Vinyl suspension seat  
 2-inch retractable seatbelt

**OPERATOR'S STATION (CAB)**

Dual side entry flat deck  
 Interior rearview mirror  
 Built-in beverage holder  
 Coat hook  
 Pre-wired for radio  
 Key start switch with electric shut-off  
 Headliner  
 2-position horn control  
 Molded floor mat  
 Electric instrumentation  
 Tachometer/hourmeter  
 Fuel gauge  
 DEF gauge  
 Interior dome light  
 Fixed steering wheel  
 USB charge port  
 Pre-wired for emergency beacon  
 Pre-wired for road headlights  
 Adjustable side window openings  
 One-piece rear window  
 Adjustable heater/blower fan  
 Adjustable front sun-screen shade  
 Cloth suspension seat  
 2-inch retractable seatbelt  
 Heater

**LOADER**

Straight loader arm design (B95D, B95D  
 LR)  
 Curved loader arm design (B95D TC)  
 4-Bar bucket linkage  
 Bucket level indicator  
 Return-to-dig feature  
 Dual lift and bucket cylinders  
 Hydromechanical self-leveling (B95D,  
 B95D LR)  
 Single lever control  
 Loader arm support  
 1.1 yd<sup>3</sup> heavy duty bucket (B95D, B95D LR)  
 1.3 yd<sup>3</sup> heavy duty bucket (B95D TC)  
 Bolt-on cutting edge  
 Mechanical self leveling (B95D TC)

**HYDRAULICS**

O-ring Face seal connectors  
 "PD" type diagnostic port connectors  
 Open center coaxial drive hydraulic  
 pump  
 7 micron spin-on filter element  
 Mechanical, Gear Pump - 151 L/min  
 (40 gpm)  
 Pilot, Axial Piston Pump - 6 to 156 L/  
 min (1.6 to 41.2 gpm)

**SAFETY AND SECURITY**

4-Post ROPS/FOPS  
 Lockable Compartments for: Engine,  
 Hydraulic System, Battery  
 Lockable fuel & DEF cap  
 Horn  
 Backup alarm

**B95D B95D TC B95D LR OPTIONAL EQUIPMENT****ENGINE**

\*110-volt engine block heater

**ELECTRICAL**

Dual batteries

**BACKHOE**

2-lever pilot controls with pattern  
 changer  
 \*Mechanical backhoe bucket quick  
 coupler  
 4-lever backhoe controls  
 2-lever ISO excavator pattern backhoe  
 controls  
 HED extendible dipperstick  
 Multiple bucket options from factory  
 Heavy-duty and extra heavy-duty back-  
 hoe buckets  
 Flip over stabilizer pads

**OPERATOR'S STATION (ROPS)**

Electric ON/OFF control of hydraulic  
 hand tool function  
 Foot-activated switch control of back-  
 hoe hammer

**OPERATOR'S STATION (CAB)**

Air conditioning system  
 Electric ON/OFF control of hydraulic  
 hand tool function  
 Foot-activated switch control of back-  
 hoe hammer  
 3-inch retractable seatbelt  
 Tilt steering wheel  
 Super deluxe Air Ride seat  
 Vinyl suspension seat  
 LED work lights

**LOADER**

Multiple buckets available  
 Mechanical Quick Coupler (B95C,  
 B95C LR)  
 Hydraulic quick coupler (B95D TC only)

**HYDRAULICS**

Backhoe hammer circuit  
 Mid-mount hand tool circuit  
 Extra function backhoe valve with  
 control pedal (less HED)  
 \*Glide Ride control system

**TOTAL VEHICLE**

Fire extinguisher  
 Special order paint colors  
 \*External rearview mirrors  
 Front fenders  
 \*Operator cooling fan  
 \*4wd driveshaft guard kit  
 Tool box (lockable)

**LOADER ATTACHMENTS**

Sweeper brooms  
 4x1 bucket  
 Auger  
 Claw  
 Forks  
 Scrap grapple  
 FFC Style Coupler

**BACKHOE ATTACHMENTS**

Hydraulic breaker  
 Hydraulic auger  
 Hydraulic thumb  
 Additional buckets

**TIRES**

Please see your dealer to discuss the  
 other tire options available.

\*Factory or Dealer installed option

**B110D BASE EQUIPMENT****ENGINE**

Dry dual-element air cleaner  
 Fuel filter w/ water separator  
 10 micron paper filter  
 Glow Plugs  
 FPT F5BFL413B Diesel  
 Diesel Oxidation Catalyst with SCR  
 Full flow engine oil filter  
 Electronic throttles – foot and rotary hand  
 Self-adjusting belt  
 High Pressure Common Rail computer

**TRANSMISSION**

Power shuttle fully synchronized gearbox,  
 4 forward/4 reverse speeds, and power-reversing torque converter  
 Two position electric disconnect on loader control and gearshift

**OUTBOARD REAR AXLE/BRAKES**

Planetary final drives  
 Button activated differential lock  
 Electric differential lock on powershift  
 Multi-plate, hydraulic, self-adjusting, self-equalizing outboard wet disc brakes  
 Independent SAHR parking/emergency brake

**FRONT AXLE**

74" tread width  
 Hydrostatic power steering with priority valve  
 Integrated steering cylinder  
 2WD axle: cast iron  
 FWD axle: cast iron  
 FWD electrical engagement with indicator light

**ELECTRICAL**

12-volt system  
 160-amp high-capacity  
 Dual wet batteries  
 Sealed fuseblock compartment  
 Water resistant main fuseblock

**LIGHTING**

8 halogen worklights  
 Stop and turn signals  
 Four-way safety flashers

**BACKHOE**

Includes: Long reach, 15-ft curved boom, Center pivot swing post, Boom cylinder and Dipper cylinder

**OPERATOR'S STATION (ROPS)**

Dual side entry flat deck  
 Interior rearview mirror  
 Built-in beverage holder  
 Key start switch with electric shut-off  
 2-position horn control  
 Electric analog instrumentation  
 Tachometer/hourmeter  
 Fuel gauge  
 DEF gauge

Tilt steering wheel (w/ Powershift)  
 Auxiliary 12-volt output/cigarette lighter  
 Pre-wired for emergency beacon  
 Pre-wired for road headlights  
 Vinyl suspension seat  
 SE3-inch retractable seatbelt

**OPERATOR'S STATION (CAB)**

Dual side entry flat deck  
 Interior rearview mirror  
 Built-in beverage holder  
 Coat hook  
 Pre-wired for radio  
 Key start switch with electric shut-off  
 Headliner  
 2-position horn control  
 Molded floor mat  
 Electric instrumentation  
 Tachometer/hourmeter  
 Fuel gauge  
 DEF gauge  
 Interior dome light  
 Tilt steering wheel (w/ Powershift)  
 USB charge port  
 Pre-wired for emergency beacon  
 Pre-wired for road headlights  
 Adjustable side window openings  
 One-piece rear window  
 Adjustable heater/blower fan  
 Adjustable front sun-screen shade  
 Cloth suspension seat  
 2-inch retractable seatbelt

**LOADER**

Straight loader arm design  
 4-Bar bucket linkage  
 Bucket level indicator  
 Return-to-dig feature  
 Dual lift and bucket cylinders  
 Hydromechanical self-leveling  
 Single lever control  
 1.3 yd<sup>3</sup> heavy duty bucket

**HYDRAULICS**

O-ring Face seal connectors  
 "PD" type diagnostic port connectors  
 Open center coaxial drive hydraulic pump  
 7 micron spin-on filter element  
 Relief valve protection  
 Mechanical, Gear Pump - 151 L/min (40 gpm)  
 Pilot, Axial Piston Pump - 6 to 156 L/min (1.6 to 41.2 gpm)

**SAFETY AND SECURITY**

4-Post ROPS/FOPS  
 Lockable compartments for: Engine, Hydraulic System, Battery  
 Lockable fuel & DEF cap  
 Battery disconnect switch  
 2" Retractable seat belt  
 Horn  
 Backup alarm

**B110D OPTIONAL EQUIPMENT****ENGINE**

Grid heater starting aid  
 \*110-volt engine block heater  
 \*Centrifugal dust bowl pre-cleaner (B110B)

**TRANSMISSION**

Powershift, 4 forward/2 reverse speeds, and power-reversing torque converter  
 Single lever F-N-R control with safety detent

**ELECTRICAL**

Single battery

**BACKHOE**

2-lever pilot controls with pattern changer  
 \*Mechanical backhoe bucket quick coupler  
 4-lever backhoe controls  
 2-lever ISO excavator pattern backhoe controls  
 HED extendible dipperstick  
 Multiple bucket options from factory  
 Heavy-duty and extra heavy-duty backhoe buckets

**OPERATOR'S STATION (ROPS)**

Electric ON/OFF control of hydraulic hand tool function  
 Foot-activated switch control of backhoe hammer

**OPERATOR'S STATION (CAB)**

Air conditioning system  
 Super deluxe Air Ride seat  
 Vinyl suspension seat  
 Speedometer  
 Tilt steering wheel  
 LED work lights

**LOADER**

Multiple buckets available  
 Aux hydraulics

**HYDRAULICS**

Backhoe hammer circuit  
 Mid-mount hand tool circuit  
 Extra function backhoe valve with control pedal (less HED)  
 \*Glide Ride control system

**TOTAL VEHICLE**

Fire extinguisher  
 Special order paint colors  
 \*External rearview mirrors  
 Front fenders  
 \*Operator cooling fan  
 \*4wd driveshaft guard kit  
 Tool Box (lockable)

**LOADER ATTACHMENTS**

Sweeper brooms  
 4x1 bucket  
 Auger  
 Claw  
 Forks  
 Scrap grapple  
 FFC Style Coupler

**BACKHOE ATTACHMENTS**

Hydraulic breaker  
 Hydraulic auger  
 Hydraulic thumb  
 Additional buckets

**TIRES**

Please see your dealer to discuss the other tire options available.

\*Factory or Dealer installed option



# World class products demand world class dealers.



The purchase of a New Holland machine is just the beginning of our relationship together. Consider your experienced New Holland Construction equipment dealer as your local partner in productivity. Assistance in selecting the right model for your operation and developing an affordable leasing or financing plan through New Holland's financing division, CNH Industrial Capital, are just a few advantages your local dealer can provide.

Your New Holland dealer's full-service capabilities bring you responsive support with genuine New Holland parts and all-makes

coverage. More importantly, we are there wherever and whenever you need us with our fully equipped service vehicles. From customized maintenance programs to professional operator and technical training, our factory-trained service and parts experts are there to assist you with any of your equipment support needs.

Your business deserves nothing less than world-class products, supported by a world-class business partner. That's your local New Holland Construction equipment dealer — your partner in productivity.



Learn more at [www.newholland.com](http://www.newholland.com)



New Holland Construction  
500 Diller Ave.  
New Holland, PA 17557

Design, materials and/or specifications are subject to change without notice and without liability therefor. Specifications are applicable to units sold in Canada, the United States, its territories and possessions, and may vary outside these areas.

© 2022 CNH Industrial America LLC. All rights reserved. New Holland is a trademark registered in the United States and many other countries, owned by or licensed to CNH Industrial N.V., its subsidiaries or affiliates. Any trademarks referred to herein, in association with goods and/or services of companies, other than owned by or licensed to CNH Industrial N.V., its subsidiaries or affiliates, are the property of those respective companies.



Safety begins with a thorough understanding of the equipment. Always make sure you and your operators read the Operator's Manual before using the equipment. Pay close attention to all safety and operating decals and never operate machinery without all shields, protective devices and structures in place.